

Maine Energy Systems  
8 Airport Road  
P.O. Box 547  
BETHEL, MAINE 04217 04217  
USA

## Testing of a pellet boiler

(12 appendices)

*This is a non CBI test report.*

### The assignment

Testing the wood pellet fired hydronic heater, model Pellematic 20 in accordance with test method ASTM 2618-13, CSA B415.1-10 and ASTM 2515-11 for compliance with EPA 40 CFR Part 60, March 16, 2015.

### Item for testing

The item tested was a hydronic heater– type Pellematic 20 with serial nr.: XUTO1479, year of production 11/2019 and manufactured by Maine Energy Systems, USA. The hydronic heater arrived at RISE on 21<sup>st</sup> November 2019. The hydronic heater had been pre-conditioned and was therefore in used condition when arriving to RISE.

The performance tests were conducted from the **27<sup>th</sup> to 30<sup>th</sup> of January 2020.**

This test report relates only to the actual item tested.

### Technical description

Pellets are charged either manually or via the suction system from the storage location into the hopper and from there via the backfire safety device to the drop stage. The burner auger transports the pellets to the burner plate where the heater rod heats them until they ignite. The ignition is monitored on the basis of the combustion chamber temperature and switches off once the pellets have ignited. The fuel and combustion air volume are automatically controlled by the combustion temperature and modulation level and the vacuum in the combustion chamber is controlled by means of the flue gas fan and burner fan. The heat exchanger is cleaned automatically with the cyclically activated cleaning spring in the heat exchanger. The ash is collected underneath the burner plate, and is transported by the ash auger into the ash bin.

The wood pellet fired hydronic heater Pellematic 20 is intended for indoor installation.

### Informative material supplied

Two manuals were delivered from the manufacturer:

- Operating manual, Pellet heating with auger delivery or vacuum suction system for the end user. PE(S)(K)(B) 10 - 56. Version: FA\_V2.03
- Installation manual – Pellet heating with vacuum suction system type AutoPellet PES 10-32, Version FA-V2.03

### RISE Research Institutes of Sweden AB

Postal address	Office location	Phone / Fax / E-mail
Box 857	Brinellgatan 4	+46 10 516 50 00
SE-501 15 BORÅS	SE-504 62 BORÅS	+46 33 13 55 02
Sweden		info@ri.se

This document may not be reproduced other than in full, except with the prior written approval of RISE.

## Test arrangement

The hydronic heater was connected to the test rig according to method ASTM E2618-13. The chimney was connected to a dilution tunnel (see appendix 11).

The chimney diameter was 150 mm (5.9 in.), with a height of about 5 m (197 in.) above the upper surface of the scale. The dilution tunnel diameter was 160 mm (6.3 in.).

The manufacturer conducted a pre-test burning of 50 hours to condition the unit before testing. The wood pellet hydronic heater Pellematic 20 is a non-catalytic appliance.

## Test procedure

Testing was carried out at/by RISE Department for Energy and Resources during January 2020 in accordance with EPA regulations 40 CFR Part 60 subpart QQQQ. Testing was performed according to ASTM 2618-13 and ASTM 2515-11.

The particulate matter from the probe assembly was handled according to the alternative method 126 dated March 6 2018 (broadly applicable) by rinsing the probe and probe assembly with acetone, drying down the rinse in beakers, desiccation followed by weighing (see appendix 10).

Calculation of the average overall thermal efficiency ( $\eta_{SLM}$ ) was done in accordance with Canadian standard CSA B415.1-10, clause 13.7 except for 13.7.2 (e), (f), (g), and (h) where the following average fuel properties for oak were used: C = 50.0 %, H = 6.6 %, O = 43.2 %, Ash = 0.2 %. The higher heating value (HHV) 8600 Btu/lb (19.99 MJ/kg) and the lower heating value (LHV) 7988 Btu/lb (18.567 MJ/kg) were used when calculating the efficiencies.

CO, CO<sub>2</sub> and O<sub>2</sub> emissions were measured continuously in the chimney during the test period. Emissions of CO in g/min were calculated according to the Canadian standard CSA B415.1-10 clause 13.9 (using the spreadsheet in annex F, CSA B415.1-10).

The test fuel used was manufactured by Turmberger Pelletsproduktion GmbH and is classified as EN plus pellet and A1 according to ISO 17225-2. The fuel was delivered in 15 kg plastic bags.

Leakage checks of the particulate sampling trains were carried out before and after the tests (see appendix 4).

Instead of the thermopile on the load side of the heat exchanger one pair of PT-100 sensors were used to measure the temperatures. This was communicated with EPA by email (17/05/2016) and was approved. The PT-100 sensor has a higher accuracy and a higher sensitivity compared to the thermocouple.

The appliance was in operation at the specified draw rate two hours before the test started. The test period lasted for 4 hours at each heat output rate category according to method E2618-13 clause 12.3.3.

Representative from the company Ökofen, Austria were present as observers during the tests.

**Summary of test results (Hangtag information)**

Table 1 shows a summary of the test results and a hangtag information for the hydronic heater Pellematic 20. For complete results see appendix 2.

**Table 1. Additional (Hangtag) information.**

MANUFACTURER:	<b>Maine Energy Systems 8 Airport Road P.O. Box 547 BETHEL, MAINE 04217 04217 USA</b>		
MODEL NUMBER:	<b>Pellematic 20</b>		
8-HOUR OUTPUT RATING	$Q_{out-8hr}$	<b>N.A</b>	Btu/hr
8-HOUR AVERAGE EFFICENCY	$\eta_{avg-8hr}$	<b>N.A</b>	(Using higher heating value)
		<b>N.A</b>	(Using lower heating value)
MAXIMUM OUTPUT RATING	$Q_{max}$	<b>68,300</b>	BTU/HR
ANNUAL EFFICIENCY RATING:	$\eta_{avg}$	<b>74.3</b>	(Using higher heating value)
		<b>80.0</b>	(Using lower heating value)
PARTICLE EMISSIONS:	$E_{avg}$	<b>0.227</b>	Grams/hr (Average)
		<b>0.028</b>	lbs/mmBtu Output
CO EMISSIONS	$CO_{avg}$	<b>0.019</b>	Grams/minute

**N.A** = Not Applicable because the hydronic heater is an automatic pellet fuelled appliance.

**Comments and observations**

The wood pellet hydronic heater Pellematic 20 manufactured by Maine Energy Systems, USA meets the step 2 requirement 2020 for PM emissions in EPA 40 CFR Part 60 of 0.10 lb/mmBtu heat output (average) and at each individual test rate.

The model Pellematic 20 is safety tested by OMNI –Test Laboratories, Inc (report no. 0444PB004S).

The tested model has a rated output of 68,300 Btu/hr (20 kW).

This test report shall not be reproduced except in full, without the written approval of the test laboratory.

**Quality assurance**

RISE Research Institute of Sweden AB is accredited according to ISO/IEC 17025 as well as accredited by EPA as a test lab to perform tests according to EPA 40 CFR Part 60 subpart QQQQ.

**RISE Research Institutes of Sweden AB  
Energy and circular economy - Combustion and Aerosol Technology**

Performed by

Examined by

Henrik Persson

Anna Sager

**Appendices**

Appendix 1 Identification

Appendix 2 Results

Appendix 3 Dilution tunnel traverse measurements

Appendix 4 Sampling equipment leakage check

Appendix 5 Proportional rate variation

Appendix 6 Filter, gasket and rinse weights

Appendix 7 Technician notes

Appendix 8 Instrument and uncertainties

Appendix 9 Test setup

Appendix 10 Alternative method

Appendix 11 Calibrations

Appendix 12 Operating and installation manuals

Appendix 1

Identification

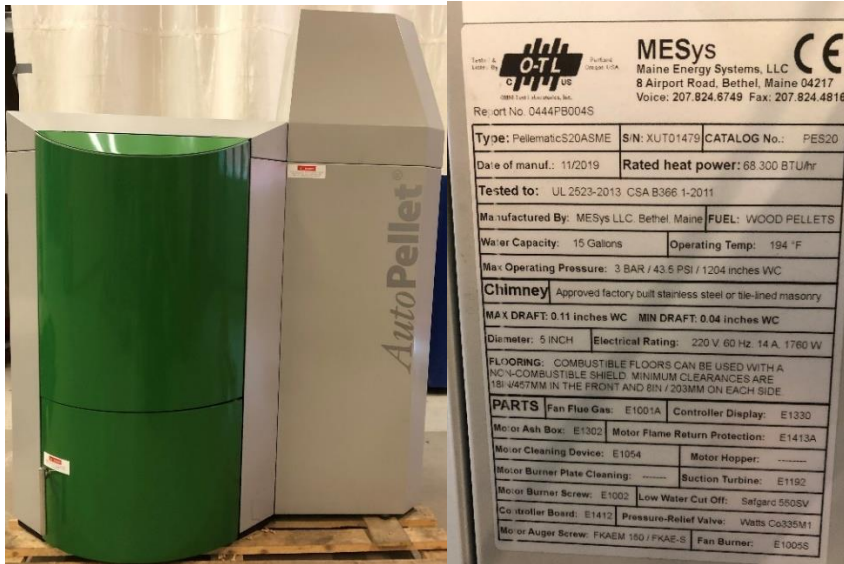

Figure 1a. Pellematic 20



Figure 1b Sealed boiler after testing

Technical data

A summary of the technical data is shown in table 2

Table 2. Technical data

Nominal output, Btu/h (kW)	68,300 (20)
Gross weight empty, lbs (kg)	631 (286)
Water content, gal (l)	15.0 (66)
Dimensions, (height x depth x width), inch (mm)	43 x 32 x 44 1/2 (1100 x 814 x 1130)
Electrical connection	208 to 240 VAC, single phase, 60 Hz, 15 amp

Appendix 2

**Results**

Table 3 show the test results for the hydronic heater Pellematic 20. Further test results are presented in tables 4 to 8.

**Table 3. Test results from Category IV to I**

	Unit	Category IV Run 1	Category III Run 1	Category II Run 1	Category I Run 1
Test date		27/01/2020	28/01/2020	29/01/2020	30/12/2020
Atmospheric pressure	mm Hg (mbar)	738 (984)	724 (965)	725 (967)	731 (975)
Test duration	minute	240	240	240	240
Absolute average gas static pressure in dilution tunnel	mm Hg	739	725	726	732
Average velocity in dilution tunnel	m/s	8.4	8.3	8.4	8.3
Average gas tunnel temperature (at Pitot tube)	°F (°C)	86 (30)	75 (24)	70 (21)	72 (22)
Average temperature at PM filter, sampling train 1	°F (°C)	75 (24)	70 (21)	68 (20)	70 (21)
Average temperature at PM filter, sampling train 2	°F (°C)	72 (22)	70 (21)	68 (20)	68 (20)
Flue gas temp (chimney)	°F (°C)	306 (152)	217 (103)	162 (72)	153 (67)
Average temperature of the appliance and water at start of the test	°F (°C)	144 (62)	147 (64)	150 (66)	148 (64)
Average temperature of the appliance and water at the end of the test	°F (°C)	144 (62)	146 (64)	148 (65)	152 (67)
Average temperature of return water as it enters the appliance	°F (°C)	126 (52)	129 (54)	131 (55)	135 (57)
Average temperature of supply water as it leaves the appliance	°F (°C)	163 (73)	163 (73)	167 (75)	165 (74)
Average inlet temperature load side of the heat exchanger	°F (°C)	111 (44)	111 (44)	113 (45)	111 (44)
Average outlet temperature load side of the heat exchanger	°F (°C)	149 (65)	136 (58)	127 (53)	120 (49)
Test load as fired	lb (kg)	43.40 (19.69)	19.84 (9.00)	9.71 (4.41)	6.83 (3.10)
Fuel moisture content on dry basis	%	6.6	6.6	6.6	6.6
Diameter of pellet	mm	6	6	6	6
Water flow rate load side	gal/min (l/min)	3.76 (14.24)	2.60 (9.84)	2.18 (8.3)	2.07 (7.9)
Heat output (load side)	Btu/hr (kW)	70,418 (20.6)	32,229 (9.4)	15,270 (4.5)	9,323 (2.7)

## Appendix 2

	Unit	Category IV Run 1	Category III Run 1	Category II Run 1	Category I Run 1
Efficiency delivered (HHV)	%	80.4	80.5	77.9	67.7
Efficiency delivered (LHV)	%	86.6	86.7	83.9	72.9
Stack loss efficiency (HHV) <sup>1</sup>	%	83.2	85.3	87.4	86.0
CO (mean value)	ppm	35	30	35	110
CO (mean value)	%	0.0035	0.0030	0.0035	0.0110
CO <sub>2</sub> (mean value)	%	11.4	9.5	8.8	5.9
O <sub>2</sub> , (mean value)	%	9.1	11.0	11.8	14.9
CO, (mean) <sup>2</sup>	g/min	0.028	0.014	0.008	0.027
Room air blank filter	mg	0.07	0.04	0	0.05
Total amount of particulate matter collected in dilution tunnel, sampling train 1	g	3.72	1.08	0.36	0.40
Total amount of particulate matter collected in dilution tunnel, sampling train 2	g	4.89	0.88	0.70	0.96
Average gas flow rate in dilution tunnel	dscm/min	9.33	9.19	9.41	9.45
Absolute average dry gas meter temperature, sampling train 1	K	294	294	293	293
Absolute average dry gas meter temperature, sampling train 2	K	294	293	293	293
Volume of gas sample measured corrected to standard conditions, sampling train 1	dscm	1.4243	1.2451	1.2705	1.2837
Volume of gas sample measured corrected to standard conditions, sampling train 2	dscm	1.1840	1.2665	1.2443	1.1880
Volume of room air gas sample measured corrected to standard conditions	dscm	1.1851	1.1587	1.1708	1.1821
Difference of PM between the two sampling trains <sup>3</sup>	g/kg <sub>dry</sub>	0.07	0.02	0.09	0.20

<sup>1</sup> Stack loss efficiency calculated according to CSA B415.1-10.

<sup>2</sup> CO emission in g/min calculated according to B415.1-10.

<sup>3</sup> The requirement in ASTM 2515-11 for the difference between the two sampling trains are maximum 0.5 g/kg dry fuel

Appendix 2

Tables 4 to 8 refer to the corresponding tables in ASTM E2618-13.

Table 4. Test condition summary

						$\Theta$	$W_{fuel}$	$MC_{ave}$	$Q_{in}$	$Q_{out}$
Category	Run No	Load % Capacity	Target Load	Actual Load	Actual Load	Test Duration	Wood Weight as-fired	Wood Moisture	Heat Input	Heat Output
			Btu/hr	Btu/hr	% of max	hrs	lb	% DB	Btu	Btu
<b>I</b>	1	$\leq 15$	$\leq 10,245$	9,323	13.7	4.0	6.83	6.6	55,078	37,293
<b>II</b>	1	16 - 24	10,928 – 16,392	15,270	22.4	4.0	9.71	6.6	78,363	61,078
<b>III</b>	1	25 - 50	17,075 – 34,150	32,229	47.2	4.0	19.84	6.6	160,075	128,917
<b>IV</b>	1	100	68,300	70,418	103.1	4.0	43.40	6.6	350,225	281,674

Table 5. Test results summary

			T2 min	$E_T$	E	E	$E_{g/hr}$	$E_{g/kg}$	$\eta_{del}$	$\eta_{SLM}$
Category	Run No	Load % Capacity	Min return water temp	Total PM emissions	PM output based	PM output based	PM rate	PM factor	Delivered efficiency	Stack loss efficiency
			°F	g	lb/mmBtu out	g/MJ	g/hr	g/kg	%	%
<b>I</b>	1	$\geq 15$	132	0.68	0.040	0.017	0.171	0.236	67.7	86.0
<b>II</b>	1	16 - 24	128	0.53	0.019	0.008	0.133	0.129	77.9	87.4
<b>III</b>	1	25 - 50	126	0.98	0.017	0.007	0.245	0.116	80.5	85.3
<b>IV</b>	1	100	124	4.23	0.029	0.014	1.061	0.230	80.4	83.2



Appendix 2

**Table 6. Heating season weighting**

Category	Weighting factor ( $F_i$ )	$\eta_{del,i} \times F_i$	$E_{g/MJ,i} \times F_i$	$E_{g/kg,i} \times F_i$	$E_{lb/mmBtu Out,i} \times F_i$	$E_{g/hr,i} \times F_i$	$CO_{g/min} \times F_i$
<b>I</b>	0.175	11.85	0.0030	0.0413	0.0070	0.0299	0.0047
<b>II</b>	0.275	21.42	0.0022	0.0355	0.0052	0.0366	0.0022
<b>III</b>	0.450	36.23	0.0032	0.0522	0.0077	0.1103	0.0063
<b>IV</b>	0.100	8.04	0.0014	0.0230	0.0029	0.1061	0.0028
<b>Totals</b>	<b>1.000</b>	<b>77.54</b>	<b>0.010</b>	<b>0.152</b>	<b>0.023</b>	<b>0.283</b>	<b>0.016</b>

**Table 7. Year-Round use weighting**

Category	Weighting factor ( $F_i$ )	$\eta_{del,i} \times F_i$	$E_{g/MJ,i} \times F_i$	$E_{g/kg,i} \times F_i$	$E_{lb/mmBtu Out,i} \times F_i$	$E_{g/hr,i} \times F_i$	$CO_{g/min} \times F_i$
<b>I</b>	0.437	29.58	0.0074	0.1031	0.0175	0.0747	0.0118
<b>II</b>	0.238	18.54	0.0019	0.0307	0.0045	0.0317	0.0019
<b>III</b>	0.275	22.14	0.0019	0.0319	0.0047	0.0674	0.0039
<b>IV</b>	0.050	4.02	0.0007	0.0115	0.0015	0.0531	0.0014
<b>Totals</b>	<b>1.000</b>	<b>74.28</b>	<b>0.012</b>	<b>0.177</b>	<b>0.028</b>	<b>0.227</b>	<b>0.019</b>

Table 9 show the PM emissions from the first hour of measurement measured by one of the two sampling trains (train 2 probe 2).

**Table 8. First hour emissions**

Category	1 <sup>st</sup> hour emissions (g/hr)
<b>I</b>	0.17
<b>II</b>	0.13
<b>III</b>	0.17
<b>IV</b>	1.66

Appendix 2

Figures 2 a-e shows the heat output (load side) in Btu/hr during the tests.

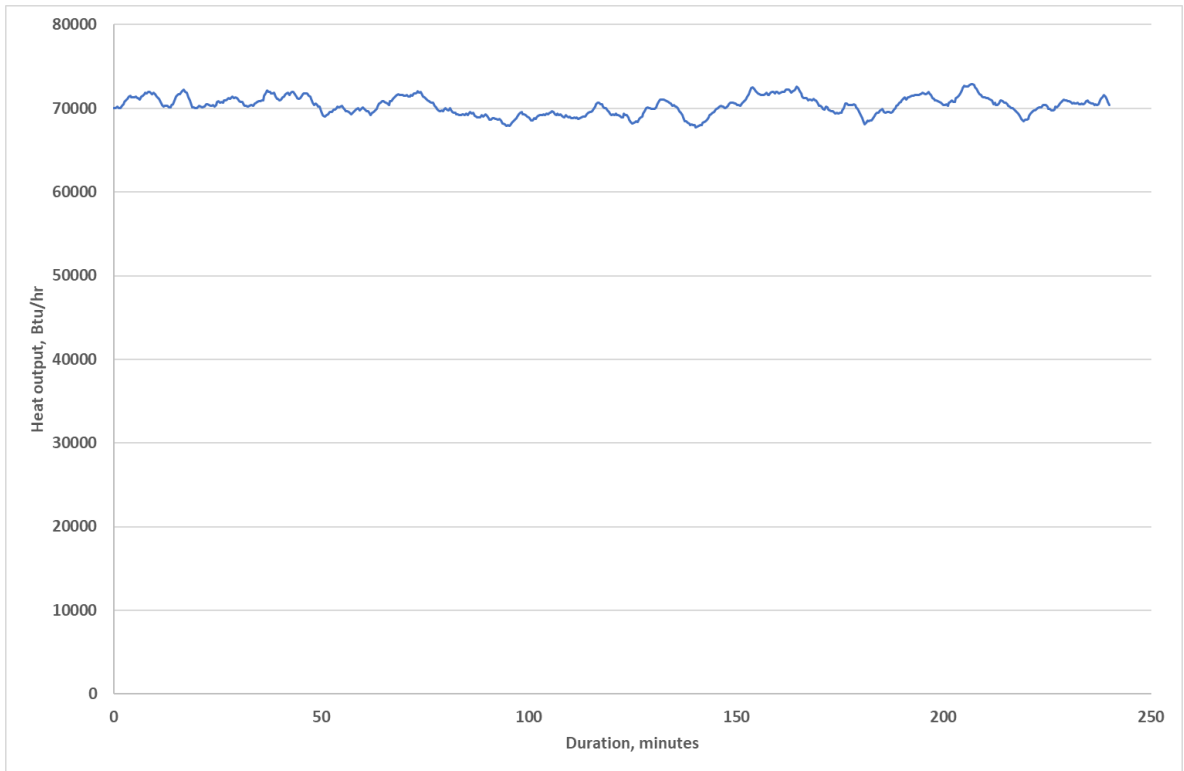

Figure 2 a. Heat output Category IV run 1

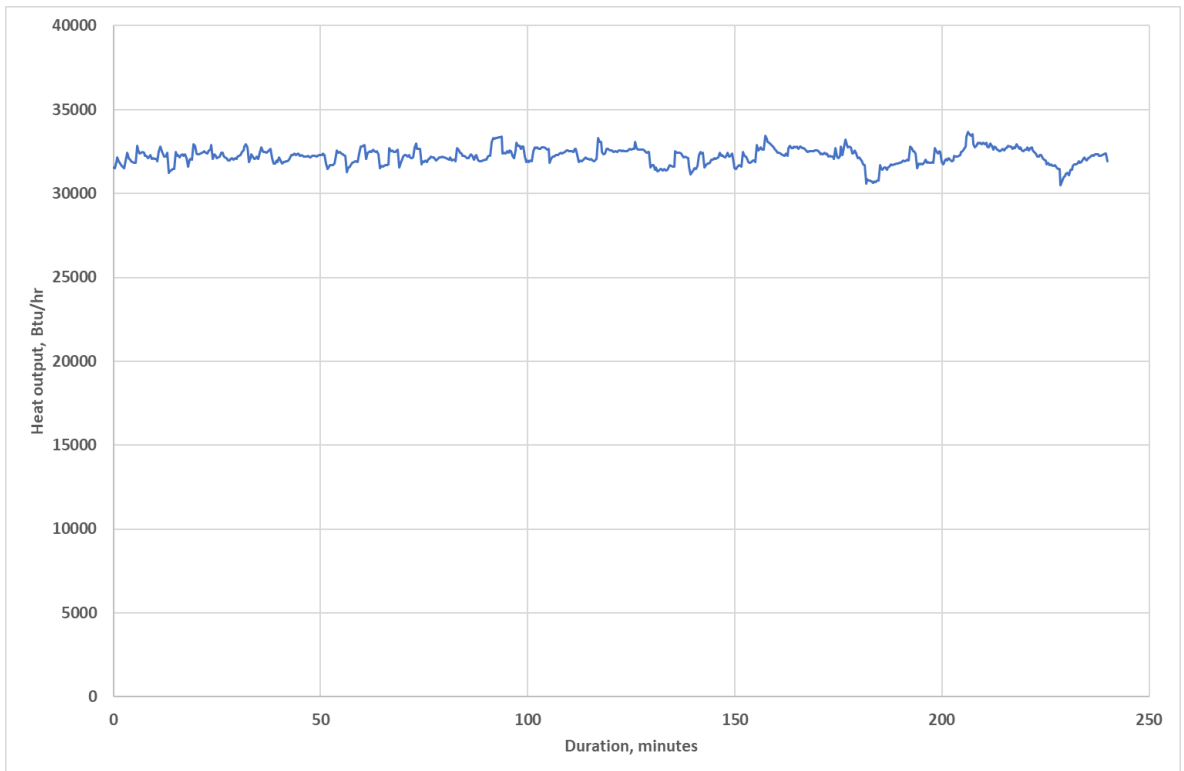
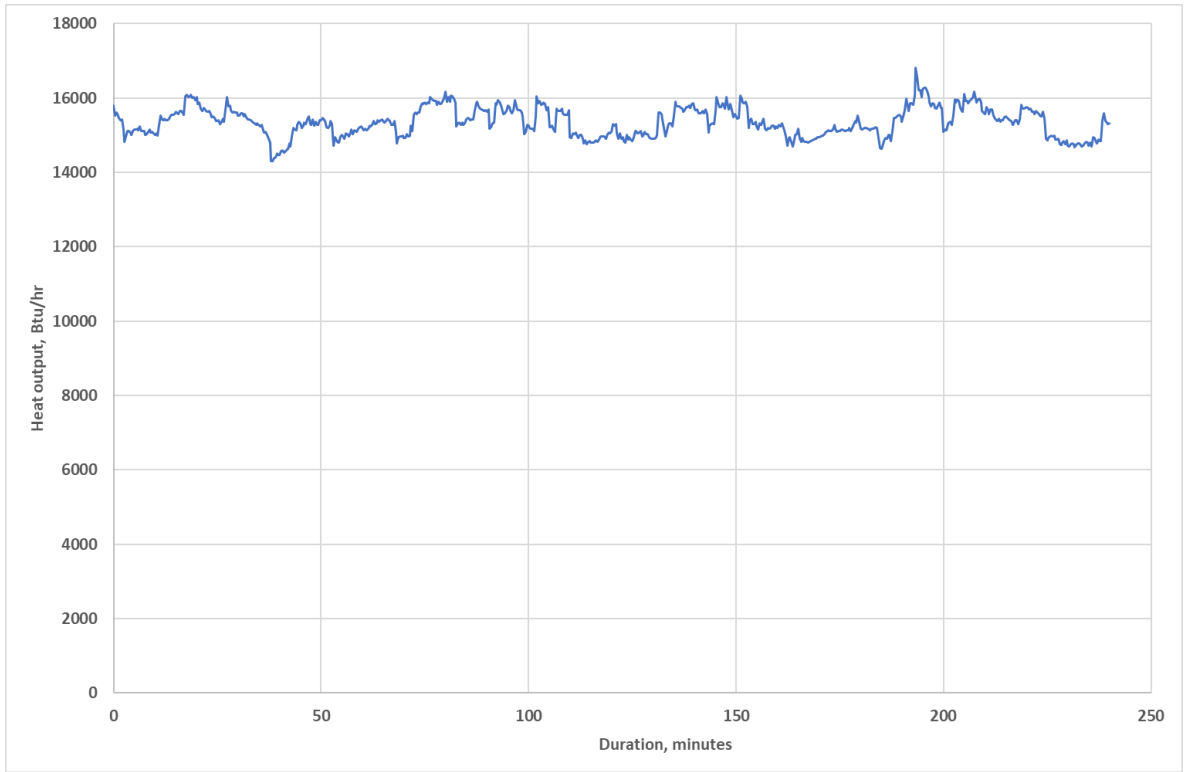
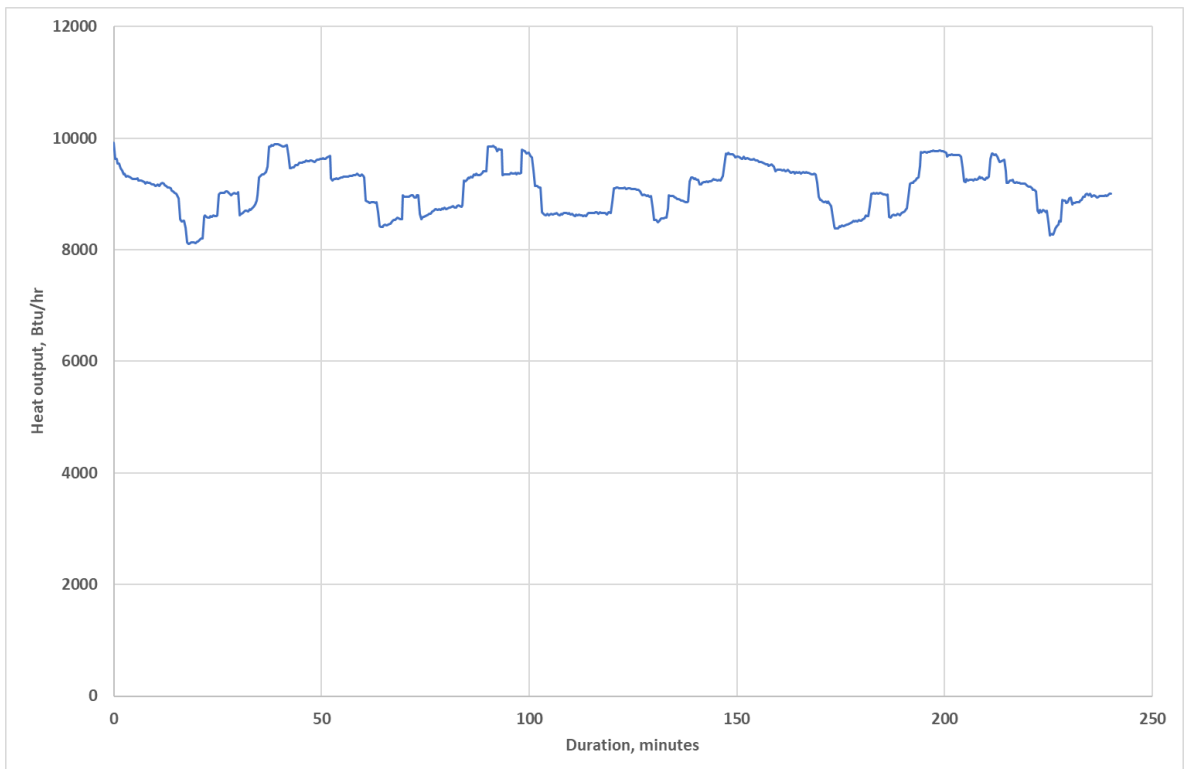

Figure 2 c. Heat output Category III run 1

Appendix 2



**Figure 2 d. Heat output Category II run 1**



**Figure 2 f. Heat output Category I run 1**

Appendix 3

**Dilution tunnel velocity traverse measurement**

The dilution tunnel inside diameter was 160 mm (6.3 inch) and cross sectional area was 0.02 m<sup>2</sup> ( 0.22 ft<sup>2</sup>).

**Table 9. Dilution tunnel traverse**

Traverse point	% of diameter (160 mm)	Temperature, °C (F)	Velocity, m/s
Y1	6.7	20.7	7.52
Y2	25.0	20.8	8.41
Centre	50.0	20.8	9.15
Y3	75.0	20.8	8.74
Y4	93.3	20.8	7.64
X1	6.7	20.8	7.83
X2	25.0	20.8	8.52
Centre	50.0	20.8	9.08
X3	75.0	20.8	8.78
X4	93.3	20.8	7.56
V <sub>strav</sub> , average (Y + X)	-	-	8.13
V <sub>scent</sub> , average (Centre)	-	-	9.12

$$F_p = \frac{V_{strav}}{V_{scent}} = \frac{8.13}{9.12} = 0.8914$$

The F<sub>p</sub> factor has been included in the calculations of the particulate results.

Appendix 4

### Sampling equipment leakage check

The leakage check of the sampling trains were performed at a vacuum of 380 mm Hg (0.5 bar). This vacuum was not exceeded during the test periods.

Table 10a. Category IV

	Leakage rate m <sup>3</sup> /min		Requirement, 0.0003 m <sup>3</sup> /min
	Pre-test	Post-test	
<b>Sampling train 1</b>	0.0000	0.00005	OK
<b>Sampling train 2</b>	0.0001	0.0002	OK
<b>Sampling train 3</b>	0.00015	0.0002	OK
<b>Ambient train</b>	0.00025	0.00025	OK

Table 10b. Category III

	Leakage rate m <sup>3</sup> /min		Requirement, 0.0003 m <sup>3</sup> /min
	Pre-test	Post-test	
<b>Sampling train 1</b>	0.0002	0.0002	OK
<b>Sampling train 2</b>	0.00025	0.00025	OK
<b>Sampling train 3</b>	0.0000	0.0000	OK
<b>Ambient train</b>	0.0002	0.0002	OK

Table 10c. Category II

	Leakage rate m <sup>3</sup> /min		Requirement, 0.0003 m <sup>3</sup> /min
	Pre-test	Post-test	
<b>Sampling train 1</b>	0.000025	0.00028	OK
<b>Sampling train 2</b>	0.0002	0.0002	OK
<b>Sampling train 3</b>	0.0001	0.0001	OK
<b>Ambient train</b>	0.0002	0.0002	OK

Table 10d. Category I

	Leakage rate m <sup>3</sup> /min		Requirement, 0.0003 m <sup>3</sup> /min
	Pre-test	Post-test	
<b>Sampling train 1</b>	0.0001	0.0001	OK
<b>Sampling train 2</b>	0.00005	0.0001	OK
<b>Sampling train 3</b>	0.0001	0.0000	OK
<b>Ambient train</b>	0.0002	0.0002	OK

Appendix 5

**Proportional rate variation**

Table 11a to 11h shows the proportional rate variation of the sampling trains.

**Table 11a. Category IV run 1 sampling train 1**

PROBE 1 Cat IV, run 1, 27-01-2020																										
	i1	i2	i4	i5	i6	i7	i8	i9	i10	i11	i12	i13	i14	i15	i16	i17	i18	i19	i20	i21	i22	i23	i24	i25		
Time total, minute	Ø	240,00	240,00	240,00	240,00	240,00	240,00	240,00	240,00	240,00	240,00	240,00	240,00	240,00	240,00	240,00	240,00	240,00	240,00	240,00	240,00	240,00	240,00	240,00		
Gas meter volume of gas sample during 10 min interval, m <sup>3</sup>	V <sub>m</sub>	0,06	0,06	0,06	0,06	0,06	0,06	0,06	0,06	0,06	0,06	0,06	0,06	0,06	0,06	0,06	0,06	0,06	0,06	0,06	0,06	0,06	0,06	0,06		
Average gas velocity in tunnel, m/s	V <sub>g</sub>	9,085	9,085	9,085	9,085	9,085	9,085	9,085	9,085	9,085	9,085	9,085	9,085	9,085	9,085	9,085	9,085	9,085	9,085	9,085	9,085	9,085	9,085	9,085		
Absolute average dry gas meter temperature, K	T <sub>m</sub>	293,984	293,984	293,984	293,984	293,984	293,984	293,984	293,984	293,984	293,984	293,984	293,984	293,984	293,984	293,984	293,984	293,984	293,984	293,984	293,984	293,984	293,984	293,984		
Absolute average gas temperature in tunnel during 10 minute interval, K (pitot)	T <sub>g</sub>	303,84	303,91	303,89	303,93	303,78	303,62	303,40	302,71	302,24	302,47	302,30	302,55	302,65	302,72	302,53	302,63	302,64	302,60	302,56	302,52	302,66	302,63	302,62	302,64	
Volume of gas sample total, m <sup>3</sup>	V <sub>m</sub>	1,45	1,45	1,45	1,45	1,45	1,45	1,45	1,45	1,45	1,45	1,45	1,45	1,45	1,45	1,45	1,45	1,45	1,45	1,45	1,45	1,45	1,45	1,45		
Average gas velocity in tunnel for 10 min interval, m/s	V <sub>g</sub>	8,98	8,98	8,97	9,01	9,09	9,09	9,09	9,10	9,11	9,10	9,11	9,10	9,11	9,11	9,11	9,10	9,11	9,10	9,11	9,11	9,11	9,12	9,11	9,10	
Absolute average gas temperature in tunnel (pitot), K	T <sub>i</sub>	302,92	302,92	302,92	302,92	302,92	302,92	302,92	302,92	302,92	302,92	302,92	302,92	302,92	302,92	302,92	302,92	302,92	302,92	302,92	302,92	302,92	302,92	302,92	302,92	
Absolute average dry gas meter temperature during 10 minute interval, K (probe i)	T <sub>m</sub>	293,23	293,27	293,34	293,42	293,52	293,63	293,74	293,82	293,90	293,98	294,05	294,11	294,17	294,21	294,24	294,27	294,30	294,32	294,33	294,34	294,34	294,35	294,37	294,37	
Actual time when reading, minute	Ø	10	10	10	10	10	10	10	10	10	10	10	10	10	10	10	10	10	10	10	10	10	10	10	10	
Results		105	102	104	101	102	100	100	100	99	100	100	99	100	98	100	99	99	99	98	100	99	99	98	99	
Requirement		90-110	90-110	90-110	90-110	90-110	90-110	90-110	90-110	90-110	90-110	90-110	90-110	90-110	90-110	90-110	90-110	90-110	90-110	90-110	90-110	90-110	90-110	90-110	90-110	
Fail/ok		ok	ok	ok	ok	ok	ok	ok	ok	ok	ok	ok	ok	ok	ok	ok	ok	ok	ok	ok	ok	ok	ok	ok	ok	ok
Requirement 2		80-120	80-120	80-120	80-120	80-120	80-120	80-120	80-120	80-120	80-120	80-120	80-120	80-120	80-120	80-120	80-120	80-120	80-120	80-120	80-120	80-120	80-120	80-120	80-120	
Fail 2/ok																										

**Table 11b. Category IV run 1 sampling train 2 and 3**

PROBE 2+3 Cat IV, run 1, 27-01-2020																										
	Probe2 i1	Probe2 i2	Probe2 i4	Probe2 i5	Probe2 i6	Probe2 i7	Probe2 i8	Probe3 i9	Probe3 i10	Probe3 i11	Probe3 i12	Probe3 i13	Probe3 i14	Probe3 i15	Probe3 i16	Probe3 i17	Probe3 i18	Probe3 i19	Probe3 i20	Probe3 i21	Probe3 i22	Probe3 i23	Probe3 i24	Probe3 i25		
Time total, minute	Ø	60,00	60,00	60,00	60,00	60,00	60,00	178,00	178,00	178,00	178,00	178,00	178,00	178,00	178,00	178,00	178,00	178,00	178,00	178,00	178,00	178,00	178,00	178,00		
Gas meter volume of gas sample during 10min interval, m <sup>3</sup>	V <sub>m</sub>	0,05	0,05	0,05	0,05	0,05	0,05	0,04	0,05	0,05	0,05	0,05	0,05	0,05	0,05	0,05	0,05	0,05	0,05	0,05	0,05	0,05	0,05	0,05		
Average gas velocity in tunnel, m/s	V <sub>g</sub>	9,019	9,019	9,019	9,019	9,019	9,019	9,107	9,107	9,107	9,107	9,107	9,107	9,107	9,107	9,107	9,107	9,107	9,107	9,107	9,107	9,107	9,107	9,107		
Absolute average dry gas meter temperature, K	T <sub>m</sub>	293,399	293,399	293,399	293,399	293,399	293,399	293,706	293,706	293,706	293,706	293,706	293,706	293,706	293,706	293,706	293,706	293,706	293,706	293,706	293,706	293,706	293,706	293,706		
Absolute average gas temperature in tunnel during 10 minute interval, K (pitot)	T <sub>g</sub>	303,84	303,91	303,89	303,93	303,78	303,62	303,36	302,71	302,24	302,47	302,30	302,55	302,65	302,72	302,53	302,63	302,64	302,60	302,56	302,52	302,66	302,63	302,62	302,64	
Volume of gas sample total, m <sup>3</sup>	V <sub>m</sub>	0,30	0,30	0,30	0,30	0,30	0,30	0,93	0,93	0,93	0,93	0,93	0,93	0,93	0,93	0,93	0,93	0,93	0,93	0,93	0,93	0,93	0,93	0,93		
Average gas velocity in tunnel for 10 min interval, m/s	V <sub>g</sub>	8,98	8,98	8,97	9,01	9,09	9,09	9,09	9,10	9,11	9,10	9,11	9,10	9,11	9,11	9,11	9,10	9,11	9,10	9,11	9,11	9,11	9,12	9,11	9,10	
Absolute average gas temperature in tunnel (pitot), K	T <sub>i</sub>	303,83	303,83	303,83	303,83	303,83	303,83	302,61	302,61	302,61	302,61	302,61	302,61	302,61	302,61	302,61	302,61	302,61	302,61	302,61	302,61	302,61	302,61	302,61	302,61	
Absolute average dry gas meter temperature during 10 minute interval, K (probe i)	T <sub>m</sub>	293,27	293,31	293,37	293,42	293,47	293,56	293,65	293,66	293,67	293,71	293,74	293,77	293,79	293,79	293,77	293,73	293,72	293,70	293,69	293,68	293,67	293,65	293,65	293,67	
Actual time when reading, minute	Ø	10	10	10	10	10	10	8	10	10	10	10	10	10	10	10	10	10	10	10	10	10	10	10	9,93	
Results		91	92	105	104	104	104	101	101	100	101	100	100	100	99	100	100	98	101	99	100	99	99	100	100	
Requirement		90-110	90-110	90-110	90-110	90-110	90-110	90-110	90-110	90-110	90-110	90-110	90-110	90-110	90-110	90-110	90-110	90-110	90-110	90-110	90-110	90-110	90-110	90-110	90-110	
Fail/ok		ok	ok	ok	ok	ok	ok	ok	ok	ok	ok	ok	ok	ok	ok	ok	ok	ok	ok	ok	ok	ok	ok	ok	ok	ok
Requirement 2		80-120	80-120	80-120	80-120	80-120	80-120	80-120	80-120	80-120	80-120	80-120	80-120	80-120	80-120	80-120	80-120	80-120	80-120	80-120	80-120	80-120	80-120	80-120	80-120	
Fail 2/ok																										

Appendix 5

Table 11 c. Category III run 1, sampling train 1

PROBE 1 Cat III, run 1, 28-01-2020																									
	i1	i2	i4	i5	i6	i7	i8	i9	i10	i11	i12	i13	i14	i15	i16	i17	i18	i19	i20	i21	i22	i23	i24	i25	
Time total, minute	Ø	240,00	240,00	240,00	240,00	240,00	240,00	240,00	240,00	240,00	240,00	240,00	240,00	240,00	240,00	240,00	240,00	240,00	240,00	240,00	240,00	240,00	240,00	240,00	240,00
Gas meter volume of gas sample during 10 min interval, m <sup>3</sup>	V <sub>m</sub>	0,05	0,05	0,05	0,06	0,05	0,05	0,05	0,06	0,05	0,05	0,06	0,05	0,05	0,06	0,05	0,05	0,05	0,06	0,05	0,05	0,05	0,06	0,05	0,06
Average gas velocity in tunnel, m/s	V <sub>s</sub>	9,102	9,102	9,102	9,102	9,102	9,102	9,102	9,102	9,102	9,102	9,102	9,102	9,102	9,102	9,102	9,102	9,102	9,102	9,102	9,102	9,102	9,102	9,102	9,102
Absolute average dry gas meter temperature, K	T <sub>m</sub>	293,773	293,773	293,773	293,773	293,773	293,773	293,773	293,773	293,773	293,773	293,773	293,773	293,773	293,773	293,773	293,773	293,773	293,773	293,773	293,773	293,773	293,773	293,773	293,773
Absolute average gas temperature in tunnel during 10 minute interval, K (pitot)	T <sub>s</sub>	297,84	297,21	297,09	297,00	297,00	297,03	297,06	296,91	296,85	296,80	296,76	296,76	296,81	296,85	296,80	296,73	296,69	296,69	296,69	296,70	296,70	296,67	296,65	296,58
Volume of gas sample total, m <sup>3</sup>	V <sub>m</sub>	1,29	1,29	1,29	1,29	1,29	1,29	1,29	1,29	1,29	1,29	1,29	1,29	1,29	1,29	1,29	1,29	1,29	1,29	1,29	1,29	1,29	1,29	1,29	1,29
Average gas velocity in tunnel for 10 min interval, m/s	V <sub>s</sub>	9,09	9,11	9,10	9,10	9,10	9,10	9,11	9,10	9,10	9,09	9,12	9,11	9,10	9,10	9,10	9,10	9,11	9,10	9,10	9,10	9,10	9,10	9,10	9,10
Absolute average gas temperature in tunnel (pitot), K	T <sub>s</sub>	296,87	296,87	296,87	296,87	296,87	296,87	296,87	296,87	296,87	296,87	296,87	296,87	296,87	296,87	296,87	296,87	296,87	296,87	296,87	296,87	296,87	296,87	296,87	296,87
Absolute average dry gas meter temperature during 10 minute interval, K (probe i)	T <sub>m</sub>	293,32	293,32	293,36	293,41	293,49	293,57	293,64	293,71	293,76	293,81	293,84	293,88	293,90	293,93	293,94	293,95	293,95	293,97	293,97	293,98	293,96	293,95	293,98	293,97
Actual time when reading, minute	Ø	10	10	10	10	10	10	10	10	10	10	10	10	10	10	10	10	10	10	10	10	10	10	10	10
Results		100	100	94	106	99	101	95	104	96	101	104	96	100	104	100	95	100	104	100	96	100	104	96	105
Requirement		90-110	90-110	90-110	90-110	90-110	90-110	90-110	90-110	90-110	90-110	90-110	90-110	90-110	90-110	90-110	90-110	90-110	90-110	90-110	90-110	90-110	90-110	90-110	90-110
Fail/ok		ok	ok	ok	ok	ok	ok	ok	ok	ok	ok	ok	ok	ok	ok	ok	ok	ok	ok	ok	ok	ok	ok	ok	ok
Requirement 2		80-120	80-120	80-120	80-120	80-120	80-120	80-120	80-120	80-120	80-120	80-120	80-120	80-120	80-120	80-120	80-120	80-120	80-120	80-120	80-120	80-120	80-120	80-120	80-120
Fail 2/ok																									

Table 11d. Category III run 1, sampling trains 2 and 3

PROBE 2+3 Cat III, run 1, 28-01-2020																										
	Probe2	Probe2	Probe2	Probe2	Probe2	Probe2	Probe3	Probe3	Probe3	Probe3	Probe3	Probe3	Probe3	Probe3	Probe3	Probe3	Probe3	Probe3	Probe3	Probe3	Probe3	Probe3	Probe3	Probe3	Probe3	
	i1	i2	i4	i5	i6	i7	i8	i9	i10	i11	i12	i13	i14	i15	i16	i17	i18	i19	i20	i21	i22	i23	i24	i25		
Time total, minute	Ø	60,00	60,00	60,00	60,00	60,00	60,00	178,00	178,00	178,00	178,00	178,00	178,00	178,00	178,00	178,00	178,00	178,00	178,00	178,00	178,00	178,00	178,00	178,00	178,00	
Gas meter volume of gas sample during 10 min interval, m <sup>3</sup>	V <sub>m</sub>	0,06	0,06	0,06	0,05	0,06	0,06	0,05	0,05	0,06	0,06	0,05	0,06	0,06	0,05	0,06	0,06	0,06	0,05	0,06	0,06	0,06	0,05	0,06	0,05	
Average gas velocity in tunnel, m/s	V <sub>s</sub>	9,100	9,100	9,100	9,100	9,100	9,100	9,103	9,103	9,103	9,103	9,103	9,103	9,103	9,103	9,103	9,103	9,103	9,103	9,103	9,103	9,103	9,103	9,103	9,103	
Absolute average dry gas meter temperature, K	T <sub>m</sub>	293,379	293,379	293,379	293,379	293,379	293,379	293,432	293,432	293,432	293,432	293,432	293,432	293,432	293,432	293,432	293,432	293,432	293,432	293,432	293,432	293,432	293,432	293,432	293,432	
Absolute average gas temperature in tunnel during 10 minute interval, K (pitot)	T <sub>s</sub>	297,84	297,21	297,09	297,00	297,00	297,03	297,06	296,91	296,85	296,80	296,76	296,76	296,81	296,85	296,80	296,73	296,69	296,69	296,69	296,69	296,70	296,70	296,67	296,65	296,58
Volume of gas sample total, m <sup>3</sup>	V <sub>m</sub>	0,34	0,34	0,34	0,34	0,34	0,34	1,00	1,00	1,00	1,00	1,00	1,00	1,00	1,00	1,00	1,00	1,00	1,00	1,00	1,00	1,00	1,00	1,00	1,00	
Average gas velocity in tunnel for 10 min interval, m/s	V <sub>s</sub>	9,09	9,11	9,10	9,10	9,10	9,10	9,11	9,10	9,10	9,09	9,12	9,11	9,10	9,10	9,10	9,10	9,11	9,10	9,10	9,10	9,10	9,10	9,10	9,10	
Absolute average gas temperature in tunnel (pitot), K	T <sub>s</sub>	297,20	297,20	297,20	297,20	297,20	297,20	296,76	296,76	296,76	296,76	296,76	296,76	296,76	296,76	296,76	296,76	296,76	296,76	296,76	296,76	296,76	296,76	296,76	296,76	
Absolute average dry gas meter temperature during 10 minute interval, K (probe i)	T <sub>m</sub>	293,30	293,31	293,36	293,39	293,43	293,48	293,53	293,52	293,49	293,47	293,45	293,44	293,42	293,42	293,42	293,42	293,42	293,40	293,41	293,41	293,41	293,39	293,38	293,41	293,41
Actual time when reading, minute	Ø	10	10	10	10	10	10	8	10	10	10	10	10	10	10	10	10	10	10	10	10	10	10	10	10	
Results		108	99	103	94	97	99	107	94	106	100	94	106	100	95	100	106	100	94	100	105	100	95	104	95	
Requirement		90-110	90-110	90-110	90-110	90-110	90-110	90-110	90-110	90-110	90-110	90-110	90-110	90-110	90-110	90-110	90-110	90-110	90-110	90-110	90-110	90-110	90-110	90-110	90-110	
Fail/ok		ok	ok	ok	ok	ok	ok	ok	ok	ok	ok	ok	ok	ok	ok	ok	ok	ok	ok	ok	ok	ok	ok	ok	ok	
Requirement 2		80-120	80-120	80-120	80-120	80-120	80-120	80-120	80-120	80-120	80-120	80-120	80-120	80-120	80-120	80-120	80-120	80-120	80-120	80-120	80-120	80-120	80-120	80-120	80-120	
Fail 2/ok																										

Appendix 5

Table 11e. Category II run 1, sampling train 1

PROBE 1 Cat II, run 1, 29-01-2020																								
	i1	i2	i4	i5	i6	i7	i8	i9	i10	i11	i12	i13	i14	i15	i16	i17	i18	i19	i20	i21	i22	i23	i24	i25
Time total, minute	θ	240,00	240,00	240,00	240,00	240,00	240,00	240,00	240,00	240,00	240,00	240,00	240,00	240,00	240,00	240,00	240,00	240,00	240,00	240,00	240,00	240,00	240,00	240,00
Gas meter volume of gas sample during 10 min interval, m <sup>3</sup>	V <sub>m</sub>	0,05	0,05	0,05	0,05	0,05	0,06	0,06	0,05	0,05	0,05	0,05	0,05	0,05	0,05	0,05	0,05	0,05	0,05	0,05	0,06	0,05	0,06	0,05
Average gas velocity in tunnel, m/s	V <sub>g</sub>	9,116	9,116	9,116	9,116	9,116	9,116	9,116	9,116	9,116	9,116	9,116	9,116	9,116	9,116	9,116	9,116	9,116	9,116	9,116	9,116	9,116	9,116	9,116
Absolute average dry gas meter temperature, K	T <sub>m</sub>	293,507	293,507	293,507	293,507	293,507	293,507	293,507	293,507	293,507	293,507	293,507	293,507	293,507	293,507	293,507	293,507	293,507	293,507	293,507	293,507	293,507	293,507	293,507
Absolute average gas temperature in tunnel during 10 minute interval, K (pitot)	T <sub>g</sub>	294,51	294,51	294,52	294,50	294,52	294,52	294,57	294,63	294,57	294,57	294,60	294,60	294,57	294,55	294,58	294,57	294,62	294,61	294,60	294,60	294,63	294,67	294,65
Volume of gas sample total, m <sup>3</sup>	V <sub>m</sub>	1,31	1,31	1,31	1,31	1,31	1,31	1,31	1,31	1,31	1,31	1,31	1,31	1,31	1,31	1,31	1,31	1,31	1,31	1,31	1,31	1,31	1,31	1,31
Average gas velocity in tunnel for 10 min interval, m/s	V <sub>g</sub>	9,11	9,11	9,12	9,11	9,11	9,11	9,11	9,11	9,12	9,11	9,11	9,12	9,12	9,12	9,11	9,11	9,12	9,12	9,12	9,12	9,12	9,12	9,12
Absolute average gas temperature in tunnel (pitot), K	T <sub>g</sub>	294,58	294,58	294,58	294,58	294,58	294,58	294,58	294,58	294,58	294,58	294,58	294,58	294,58	294,58	294,58	294,58	294,58	294,58	294,58	294,58	294,58	294,58	294,58
Absolute average dry gas meter temperature during 10 minute interval, K (probe i)	T <sub>m</sub>	293,00	293,02	293,05	293,09	293,14	293,20	293,27	293,34	293,39	293,43	293,48	293,53	293,58	293,62	293,67	293,71	293,77	293,79	293,81	293,83	293,85	293,87	293,88
Actual time when reading, minute	θ <sub>i</sub>	10	10	10	10	10	10	10	10	10	10	10	10	10	10	10	10	10	10	10	10	10	10	10
Results		97	100	101	99	92	108	101	100	101	100	101	100	100	100	100	100	100	99	100	100	99	100	100
Requirement		90-110	90-110	90-110	90-110	90-110	90-110	90-110	90-110	90-110	90-110	90-110	90-110	90-110	90-110	90-110	90-110	90-110	90-110	90-110	90-110	90-110	90-110	90-110
Fail/ok		ok	ok	ok	ok	ok	ok	ok	ok	ok	ok	ok	ok	ok	ok	ok	ok	ok	ok	ok	ok	ok	ok	ok
Requirement 2		80-120	80-120	80-120	80-120	80-120	80-120	80-120	80-120	80-120	80-120	80-120	80-120	80-120	80-120	80-120	80-120	80-120	80-120	80-120	80-120	80-120	80-120	80-120
Fail 2/ok																								

Table 11f. Category II run 1, sampling trains 2 and 3

PROBE 2+3 Cat II, run 1, 29-01-2020																								
	Probe 2	Probe 2	Probe 2	Probe 2	Probe 2	Probe 2	Probe 3	Probe 3	Probe 3	Probe 3	Probe 3	Probe 3	Probe 3	Probe 3	Probe 3	Probe 3	Probe 3	Probe 3	Probe 3	Probe 3	Probe 3	Probe 3	Probe 3	Probe 3
	i1	i2	i4	i5	i6	i7	i8	i9	i10	i11	i12	i13	i14	i15	i16	i17	i18	i19	i20	i21	i22	i23	i24	i25
Time total, minute	θ	60,00	60,00	60,00	60,00	60,00	60,00	178,00	178,00	178,00	178,00	178,00	178,00	178,00	178,00	178,00	178,00	178,00	178,00	178,00	178,00	178,00	178,00	178,00
Gas meter volume of gas sample during 10 min interval, m <sup>3</sup>	V <sub>m</sub>	0,05	0,05	0,06	0,06	0,05	0,06	0,04	0,06	0,06	0,06	0,06	0,06	0,06	0,06	0,06	0,06	0,06	0,06	0,06	0,06	0,06	0,06	0,06
Average gas velocity in tunnel, m/s	V <sub>g</sub>	9,113	9,113	9,113	9,113	9,113	9,113	9,117	9,117	9,117	9,117	9,117	9,117	9,117	9,117	9,117	9,117	9,117	9,117	9,117	9,117	9,117	9,117	9,117
Absolute average dry gas meter temperature, K	T <sub>m</sub>	292,946	292,946	292,946	292,946	292,946	292,946	293,188	293,188	293,188	293,188	293,188	293,188	293,188	293,188	293,188	293,188	293,188	293,188	293,188	293,188	293,188	293,188	293,188
Absolute average gas temperature in tunnel during 10 minute interval, K (pitot)	T <sub>g</sub>	294,51	294,51	294,52	294,50	294,52	294,52	294,57	294,63	294,57	294,57	294,60	294,60	294,60	294,57	294,55	294,58	294,57	294,62	294,61	294,60	294,60	294,63	294,65
Volume of gas sample total, m <sup>3</sup>	V <sub>m</sub>	0,33	0,33	0,33	0,33	0,33	0,33	0,99	0,99	0,99	0,99	0,99	0,99	0,99	0,99	0,99	0,99	0,99	0,99	0,99	0,99	0,99	0,99	0,99
Average gas velocity in tunnel for 10 min interval, m/s	V <sub>g</sub>	9,11	9,11	9,12	9,11	9,11	9,11	9,11	9,11	9,12	9,11	9,11	9,12	9,12	9,12	9,11	9,11	9,12	9,12	9,12	9,12	9,12	9,12	9,12
Absolute average gas temperature in tunnel (pitot), K	T <sub>g</sub>	294,51	294,51	294,51	294,51	294,51	294,51	294,60	294,60	294,60	294,60	294,60	294,60	294,60	294,60	294,60	294,60	294,60	294,60	294,60	294,60	294,60	294,60	294,60
Absolute average dry gas meter temperature during 10 minute interval, K (probe i)	T <sub>m</sub>	292,94	292,91	292,92	292,94	292,97	293,00	293,06	293,08	293,11	293,11	293,13	293,14	293,16	293,17	293,20	293,21	293,24	293,25	293,25	293,25	293,25	293,25	293,25
Actual time when reading, minute	θ <sub>i</sub>	10	10	10	10	10	10	8	10	10	10	10	10	10	10	10	10	10	10	10	10	10	10	10
Results		91	101	101	102	96	109	99	100	99	101	100	100	100	100	100	99	100	101	100	100	100	100	101
Requirement		90-110	90-110	90-110	90-110	90-110	90-110	90-110	90-110	90-110	90-110	90-110	90-110	90-110	90-110	90-110	90-110	90-110	90-110	90-110	90-110	90-110	90-110	90-110
Fail/ok		ok	ok	ok	ok	ok	ok	ok	ok	ok	ok	ok	ok	ok	ok	ok	ok	ok	ok	ok	ok	ok	ok	ok
Requirement 2		80-120	80-120	80-120	80-120	80-120	80-120	80-120	80-120	80-120	80-120	80-120	80-120	80-120	80-120	80-120	80-120	80-120	80-120	80-120	80-120	80-120	80-120	80-120
Fail 2/ok																								





Appendix 6

**Weight from filter, gasket and rinse**

The tables below show the results from the filter, gasket and rinse weighting. The filters and gasket have been weighted in pairs. The underlined values have been used in the calculation.

**Table 12 a: Filter weights.**

Test Cat:	Filter nr. Probe nr.	Pre-weight 1 g (date, RH %)	Pre-weight 2 g (date, RH %)	Post-weight 1 g (date, RH %)	Post-weight 2 g (date, RH %)
IV Run 1	AF1 (filter)	0.08759 (24/01/20, 33)	<u>0.08756</u> (27/01/20, 28)	0.08760 (28/01/20, 30)	<u>0.08758</u> (30/01/20, 27)
IV Run 1	F1, probe 1 (front+back)	0.17571 (24/01/20, 33)	<u>0.17571</u> (27/01/20, 28)	0.17748 (28/01/20, 30)	<u>0.17745</u> (30/01/20, 27)
IV Run 1	F2, probe 2 (front+back)	0.17610 (24/01/20, 33)	<u>0.17609</u> (27/01/20, 28)	0.17642 (28/01/20, 30)	<u>0.17641</u> (30/01/20, 27)
IV Run 1	F3, probe 3 (front+back)	0.17336 (24/01/20, 33)	<u>0.17335</u> (27/01/20, 29)	0.17447 (28/01/20, 30)	<u>0.17446</u> (30/01/20, 27)
III Run 1	AF2 (filter)	0.08778 (24/01/20, 33)	<u>0.08776</u> (27/01/20, 30)	0.08773 (29/01/20, 28)	<u>0.08775</u> (30/01/20, 25)
III Run 1	F4, probe 1 (front/back)	0.17442 (24/01/20, 33)	<u>0.17441</u> (27/01/20, 30)	0.17485 (29/01/20, 28)	<u>0.17485</u> (30/01/20, 25)
III Run 1	F5, probe 2 (front/back)	0.17309 (24/01/20, 33)	<u>0.17308</u> (27/01/20, 30)	0.17316 (29/01/20, 28)	<u>0.17318</u> (30/01/20, 25)
III Run 1	F6, probe 3 (front/back)	0.17312 (24/01/20, 33)	<u>0.17310</u> (27/01/20, 30)	0.17344 (29/01/20, 28)	<u>0.17344</u> (30/01/20, 25)
II Run 1	AF3 (filter)	0.08732 (24/01/20, 34)	<u>0.08731</u> (29/01/20, 28)	0.08729 (30/01/20, 28)	<u>0.08729</u> (31/01/20, 27)
II Run 1	F7, probe 1 (front/back)	0.17471 (24/01/20, 34)	<u>0.17469</u> (29/01/20, 28)	0.17483 (30/01/20, 28)	<u>0.17483</u> (31/01/20, 27)
II Run 1	F8, probe 2 (front/back)	0.17454 (24/01/20, 34)	<u>0.17454</u> (29/01/20, 28)	0.17453 (30/01/20, 28)	<u>0.17455</u> (31/01/20, 27)
II Run 1	F9, probe 3 (front/back)	0.17401 (24/01/20, 34)	<u>0.17402</u> (29/01/20, 28)	0.17416 (30/01/20, 27)	<u>0.17414</u> (31/01/20, 27)
I Run 1	AF4 (filter)	0.08866 (24/01/20, 34)	<u>0.08865</u> (30/01/20, 27)	0.08866 (31/01/20, 27)	<u>0.08866</u> (01/02/20, 30)
I Run 1	F10, probe 1 (front/back)	0.17383 (24/01/20, 34)	<u>0.17379</u> (30/01/20, 27)	0.17401 (31/01/20, 27)	<u>0.17401</u> (01/02/20, 30)
I Run 1	F11, probe 2 (front/back)	0.17679 (24/01/20, 34)	<u>0.17677</u> (30/01/20, 27)	0.17681 (31/01/20, 27)	<u>0.17681</u> (01/02/20, 30)
I Run 1	F12, probe 3 (front/back)	0.17406 (24/01/20, 34)	<u>0.17405</u> (30/01/20, 27)	0.17426 (31/01/20, 27)	<u>0.17425</u> (01/02/20, 30)
	Blank filter	0.24935	<u>0.24935</u>	0.24932	0.24931

Appendix 6

Table 12 b: Gasket weights

Test Cat.	Gasket nr. Probe nr.	Pre-weight 1 g (date)	Pre-weight 2 g (date)	Post-weight 1 g (date)	Post-weight 2 g (date)
IV Run 1	AG1 (gasket)	2.50070 (24/01/20)	<u>2.50069</u> (27/01/20)	2.50074 (28/01/20)	<u>2.50074</u> (28/01/20, +6h)
IV Run 1	G1, probe 1 (front/back)	4.99761 (24/01/20)	<u>4.99757</u> (27/01/20)	4.99771 (28/01/20)	<u>4.99771</u> (28/01/20, +6 h)
IV Run 1	G2, probe 2 (front/back)	4.89163 (24/01/20)	<u>4.89163</u> (27/01/20)	4.89175 (28/01/20)	<u>4.89178</u> (28/01/20, +6 h)
IV Run 1	G3, probe 3 (front/back)	4.36242 (24/01/20)	<u>4.36237</u> (27/01/20)	4.36270 (28/01/20)	<u>4.36271</u> (28/01/20, +6 h)
III Run 1	AG2 (gasket)	2.44555 (24/01/20)	<u>2.44555</u> (27/01/20)	2.44560 (29/01/20)	<u>2.44560</u> (30/01/20)
III Run 1	G4, probe 1 (front/back)	5.01202 (24/01/20)	<u>5.01205</u> (27/01/20)	5.01210 (29/01/20)	<u>5.01205</u> (30/01/20)
III Run 1	G5, probe 2 (front/back)	5.02664 (24/01/20)	<u>5.02665</u> (27/01/20)	5.02670 (29/01/20)	<u>5.02666</u> (30/01/20)
III Run 1	G6, probe 3 (front/back)	4.95016 (24/01/20)	<u>4.95016</u> (27/01/20)	4.95029 (29/01/20)	<u>4.95026</u> (30/01/20)
II Run 1	AG3 (gasket)	2.44607 (24/01/20)	<u>2.44609</u> (29/01/20)	2.44610 (30/01/20)	<u>2.44610</u> (31/01/20)
II Run 1	G7, probe 1 (front/back)	4.31882 (24/01/20)	<u>4.31876</u> (29/01/20)	4.31876 (30/01/20)	<u>4.31882</u> (01/02/20)
II Run 1	G8, probe 2 (front/back)	4.91056 (24/01/20)	<u>4.91058</u> (29/01/20)	4.91060 (30/01/20)	<u>4.91064</u> (01/02/20)
II Run 1	G9, probe 3 (front/back)	4.91455 (24/01/20)	<u>4.91455</u> (29/01/20)	4.91471 (30/01/20)	<u>4.91475</u> (01/02/20)
I Run 1	AG4 (gasket)	2.48800 (24/01/20)	<u>2.48800</u> (30/01/20)	2.48799 (31/01/20)	<u>2.48804</u> (01/02/20)
I Run 1	G10, probe 1 (front/back)	4.99762 (24/01/20)	<u>4.99762</u> (30/01/20)	4.99759 (31/01/20)	<u>4.99768</u> (01/02/20)
I Run 1	G11, probe 2 (front/back)	4.89167 (24/01/20)	<u>4.89167</u> (30/01/20)	4.89171 (31/01/20)	<u>4.89175</u> (01/02/20)
I Run 1	G12, probe 3 (front/back)	4.36256 (24/01/20)	<u>4.36256</u> (30/01/20)	4.36276 (31/01/20)	<u>4.36275</u> (01/02/20)
	Blank gasket	5.02663	<u>5.02669</u>	5.02668	<u>5.02669</u>

Appendix 6

Table 12 c: Probe rinse weights.

Test Cat.	Rinse nr. container Probe nr.	Pre-weight 1 container, g (date)	Pre-weight 2 container, g (date)	Post-weight 1 (cont.+rinse), g (date)	Post-weight 2 (cont.+rinse), g (date)
IV Run 1	R1 Probe 1	45.07918 (24/01/20)	<u>45.07913</u> (27/01/20)	45.07955 (29/01/20)	<u>45.07970</u> (01/02/20)
IV Run 1	R2 Probe 2	48.85410 (24/01/20)	<u>48.85429</u> (27/01/20)	48.85456 (29/01/20)	<u>48.85470</u> (01/02/20)
IV Run 1	R3 Probe 3	41.92256 (24/01/20)	<u>41.92276</u> (27/01/20)	41.92296 (29/01/20)	<u>41.92309</u> (01/02/20)
III Run 1	R4 Probe 1	41.59336 (24/01/20)	<u>41.59340</u> (27/01/20)	41.59361 (30/01/20)	<u>41.59361</u> (31/01/20)
III Run 1	R5 Probe 2	39.70519 (24/01/20)	<u>39.70533</u> (27/01/20)	39.70523 (30/01/20)	<u>39.70526</u> (31/01/20)
III Run 1	R6 Probe 3	46.31015 (24/01/20)	<u>46.31024</u> (27/01/20)	46.31023 (30/01/20)	<u>46.31023</u> (31/01/20)
II Run 1	R7 Probe 1	46.84443 (24/01/20)	<u>46.84457</u> (29/01/20)	46.84464 (30/01/20)	<u>46.84457</u> (03/02/20)
II Run 1	R8 Probe 2	47.94205 (24/01/20)	<u>47.94222</u> (29/01/20)	47.94222 (30/01/20)	<u>47.94215</u> (03/02/20)
II Run 1	R9 Probe 3	46.94352 (24/01/20)	<u>46.94361</u> (29/01/20)	46.94354 (30/01/20)	<u>46.94344</u> (03/02/20)
I Run 1	R10 Probe 1	45.24965 (24/01/20)	<u>45.24971</u> (29/01/20)	45.25023 (01/02/20)	<u>45.24971</u> (01/02/20)
I Run 1	R11 Probe 2	46.06619 (24/01/20)	<u>46.06634</u> (29/01/20)	46.06666 (01/02/20)	<u>46.06632</u> (03/02/20)
I Run 1	R12 Probe 3	17.33562 (24/01/20)	<u>17.33573</u> (29/01/20)	17.33590 (01/02/20)	<u>17.33578</u> (03/02/20)
	Aceton blank	16.07834	<u>16.07839</u>	16.07841	<u>16.07838</u>

Appendix 7

**Technician notes**

**Logg Pellematic 20, 2020**

-Participants from the manufacturer Ökofen: Michael Woegerbauer

Scale weight without water = 518,3 kg and scale weight with water = 581,0 kg



-Dilution tunnel induced static pressure in the chimney:  $9 \text{ m/s} = 0,87 \text{ Pa}$

- Flue gas recirculation in the boiler was plugged from the factory and this is also how the boiler is sold in USA.

- Boiler controller:



- scale calibration with a 5 kg calibrated weight:  $557.25 \text{ (empty)} + \text{weight } 562.25 - \text{weight } 557.25 \text{ kg}$

- Moisture pellets on dry base:  $((1017-369)-(977-369))/(977-369)*100 = 6,58 \%$

Appendix 7



- Sampling trains adjusted to a sample flow below 0,007 m<sup>3</sup>/min



**Day 1 27/01/2020**

**cat IV run 1**

- Air velocity around the boiler: 0 - 0.05 m/s
- 220 V and 60 Hz
- Static pressure in the chimney induced by the dilution tunnel = 0,35 Pa (at 9 m/s in the dilution tunnel)
- Settings on the boiler: boiler temperature = 72 C,

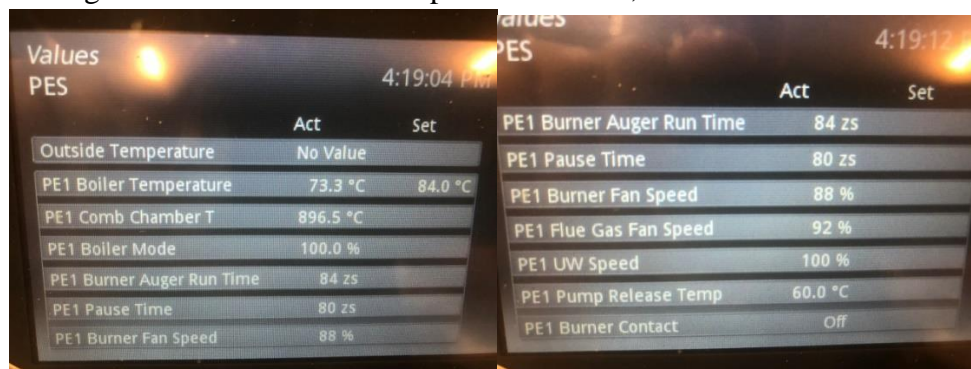

- Pstat in tunnel = 100,0 Pa

### Appendix 7

Test	Time (computer)	Weight (scale), kg	Probe 2 (gas meter 202743)	Probe 1 (gas meter 901070)	Probe 3 (gas meter 202743)	Ambient	barometer/humidity/temp.	Comments
Start pre-burn test	0:00						984mbar/RH 46 %/20 C	Test category IV run 1
Start test 1 (probe 1+2)	130:17	566.25	F2, G2	F1,G1		AF1,AG1		Stop Probe 2 (1 hour)=190,17 Gas volume=0,3010 m <sup>3</sup>
Start test probe 3	192:17				F3,G3			
End test	370:17	546.56					980 mbar/RH 47 %/20 C	

#### Day 2 28/01/2020

#### cat III run 1

- Air velocity: 0.0-0.05 m/s
- Static pressure in the chimney induced by the dilution tunnel = 0.35 Pa
- Settings on the boiler: boiler temperature at 72 C.

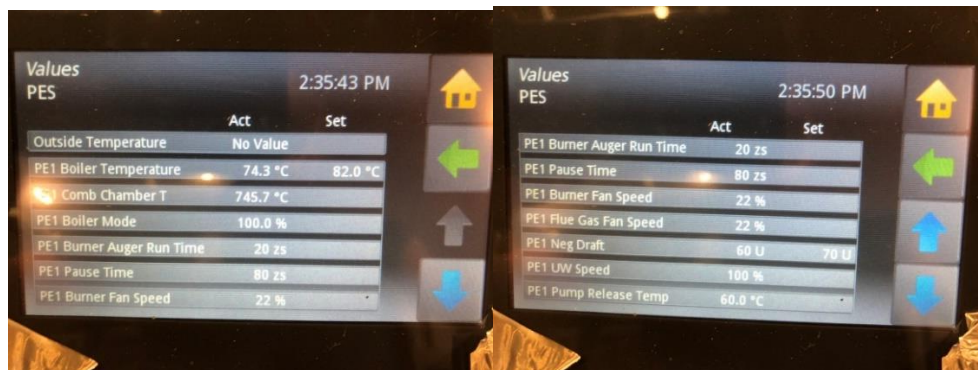

- Pstat in tunnel = 100.8 Pa

### Appendix 7

Test	Time (computer)	Weight (scale), kg	Probe 2 (gas meter 202743)	Probe 1 (gas meter 901070)	Probe 3 (gas meter 202743)	Ambient	barometer/humidity/temp.	Comments
Start pre-burn test	0:00						965/48%/20	Test category III run 1
Start test 1 (probe 1+2)	160:17	568.97	F5,G5	F4,G4				Stopp Probe 2 (1 hour)=220.17 Gas volume=0.3420 m <sup>3</sup>
Start test probe 3	222:17				F6,G6			
End test	400:17	559,97					967/48%/20	406.83 control of CO/CO2

#### Day 3 29/01/2020

#### cat II run 1

- Air velocity around the appliance: 0-0.05 m/s
- Static pressure in chimney induced by the dilution tunnel = 0.52 Pa
- Settings on the boiler: boiler temperature at 72 C.

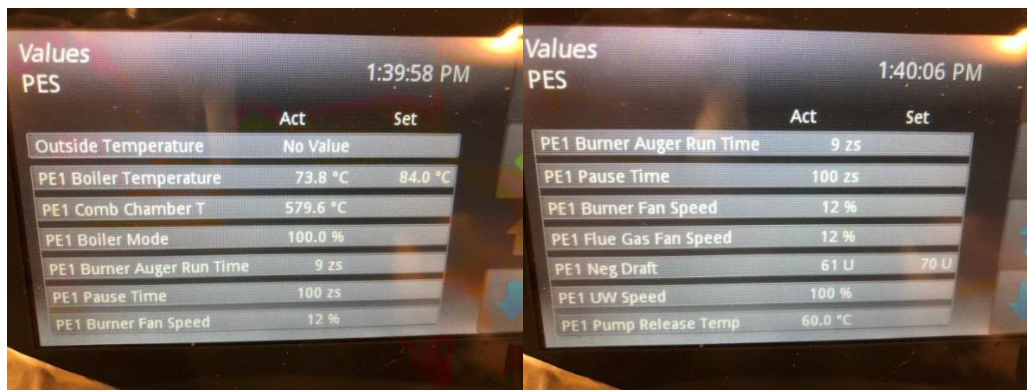

- Pstat in tunnel = 101,2 Pa



### Appendix 7

Test	Time (computer)	Weight (scale), kg	Probe 2 (gas meter 202743)	Probe 1 (gas meter 901070)	Probe 3 (gas meter 202743)	(200721) Ambient	barometer/humidity/temp.	Comments
Start pre-burn test 1	0:00						967 mbar/40% /20 C	Test category II run 1
Start test 1 (probe 2+3)	121,17	568.25	F8, G8	F7,G7		AG3, AF3		Stop Probe 2 (1 hour)=181,17 Gas volume=0,3251 m3
Start test probe 3	183,17				F9,G9			
End test 1	361,17	563.84					967 mbar/40% /20 C	Calibration control 363,17

#### Day 4 30/01/2020

#### cat I run 1

- Air velocity: 0-0.1 m/s
- Static pressure induced by the dilution tunnel = 0.47 Pa
- Settings on the boiler: boiler temperature at 72 C.

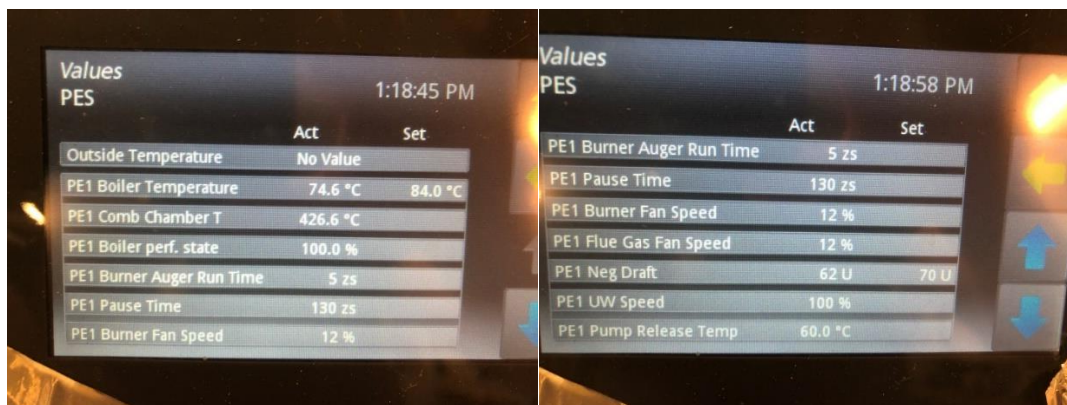

- Pstat in tunnel = 101.6 Pa

Appendix 7

Test	Time (computer)	Weight (scale), kg	Probe 2 (gas meter 202743)	Probe 1 (gas meter 901070)	Probe 3 (gas meter 202743)	Ambient (200721)	barometer/humidity/temp.	Comments
Start pre-burn test 1	0:00						975 mbar/38 %/20 C	Test category I run 1
Start test 1 (probe 1+2)	120:17	559.16	F11, G11	F10,G10				Stop Probe 2 (1 hour)=180:17 Gas Volume=0,3098
Start test probe 3	182:17				F12,G12			
End test 1	360:17	556.06					975mbar/38% /20	Calibration check 362-364

Appendix 8

**Instrumentation and uncertainty**

**Measuring instruments**

The designations listed below refer to RISE quality system

Resistance thermometer, PT-100	ETf-QD Db 2
Thermocouple, type K	ETf-QD-Db 3
Water flow meter Valmet 9V-MP150 (load side)	Inv.no. 200 783
Water flow meter Valmet 9V-MP150 (supply side)	Inv.no. 201 655
Data logging system	Inv. no. 202 561
Atmospheric pressure	Inv.no. 701 275
Scale Mettler (filter weighing)	Inv.no. BX7 2435
Particulate sampling equipment (Train 1)	Inv.no. 901 070
Particulate sampling equipment (Train 2, probe 2 and 3)	Inv.no. 202 743
Particulate sampling equipment (ambient)	Inv.no. 200 721
Differential pressure gauge Furness FCO 14 (static pressure)	Inv.no. 200 628
Differential pressure gauge Furness FCO 12 (Dynamic pressure tunnel)	Inv.no. 202 638
CO/CO <sub>2</sub> - analyser XStream (CO 0-2000 ppm)	Inv.no. 901 073
O <sub>2</sub> -analyser PMA 10	Inv.no. 202 589

**Calibration gases**

The calibration gases for calibrating the gas analyser were accredited and delivered by Air Liquide. Oxygen calibration was performed at zero and span (21 %) points.

**Table 13. Calibration gases**

	Concentration	Uncertainty	Id. No.
CO	1742 mol-ppm	1.0 % rel.	NoK9E36
CO <sub>2</sub>	15.89 mol-%	1.0 % rel.	NoK9E36

Appendix 8

**Uncertainty of measurement**

**Table 14. Uncertainty of measurements**

	Uncertainty
Temperature difference, load side	$\pm 0.05 \text{ }^\circ\text{C}$
Flue gas temperature	$\pm 1 \text{ }^\circ\text{C}$
Ambient temperature	$\pm 1 \text{ }^\circ\text{C}$
Static pressure in chimney	$\pm 10 \%$
Liquide flow, load side	$\pm 1 \%$ -of flow
Fuel quantity	$\pm 0.01 \text{ kg}$
PM filter weight	$\pm 0.1 \text{ mg}$
CO-concentration	$\pm 49 \text{ ppm}$
CO <sub>2</sub> -concentration	$\pm 0.4 \%$ -points
Boiler efficiency <sup>1</sup>	$\pm 2 \%$ -points

<sup>1</sup> Does not include losses in the test rig.

The uncertainty has been calculated according to EA-4/16 with coverage factor k=2

In table 15 the uncertainty of particulate emissions are calculated according to appendix X1 in ASTM 2515-11. The measured value is an average from the two sample probes. The uncertainty is calculated at a 95 % confidence level.

**Table 15. Particulate emission uncertainty.**

Test category	Measured value	Uncertainty
Particulates (E <sub>T</sub> ) Category IV	4.2 g	$\pm 0,32 \text{ g}$
Particulates (E <sub>T</sub> ) Category III	1,0 g	$\pm 0.31 \text{ g}$
Particulates (E <sub>T</sub> ) Category II	0.5 g	$\pm 0.32 \text{ g}$
Particulates (E <sub>T</sub> ) Category I	0.7 g	$\pm 0.32 \text{ g}$

Appendix 9

Test setup

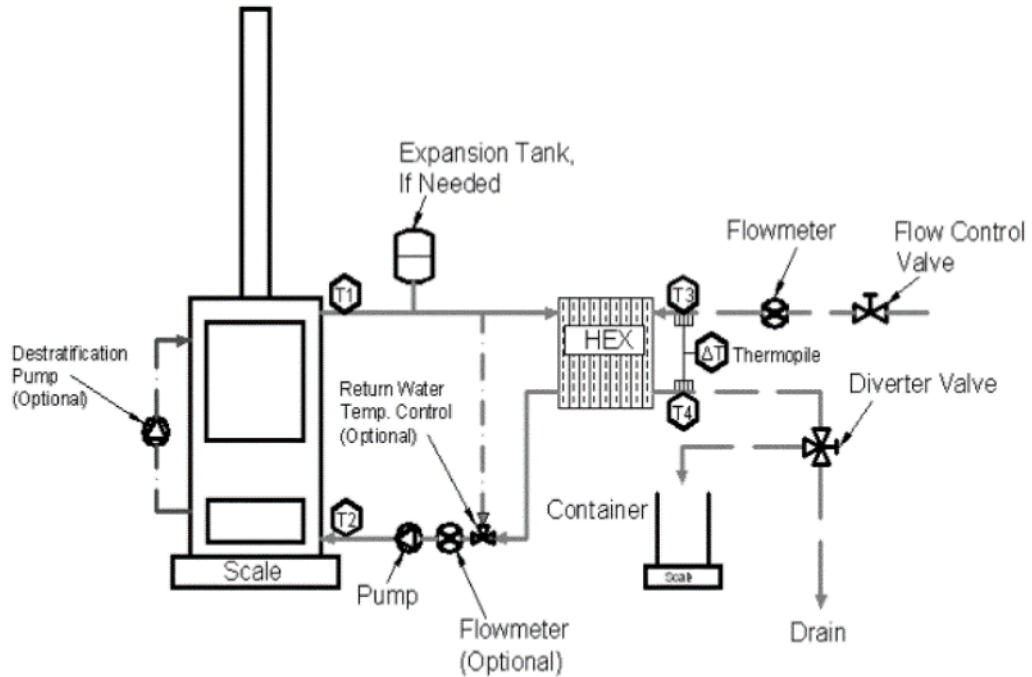

Figure 3a. Test rig

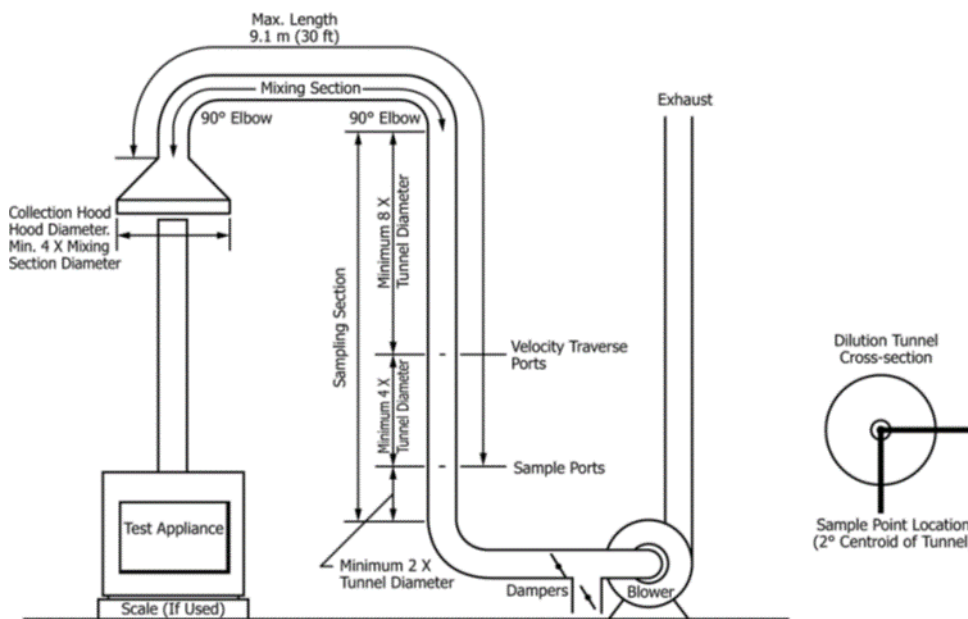

Figure 3b. Dilution tunnel

## Appendix 10



UNITED STATES ENVIRONMENTAL PROTECTION AGENCY  
RESEARCH TRIANGLE PARK, NC 27711

MAR 06 2018

OFFICE OF  
AIR QUALITY PLANNING  
AND STANDARDS

Ms. Kelli O'Brien  
Lab Manager  
ClearStak  
99 Canal Street  
Putnam, CT 06260

Dear Ms. O'Brien,

I am writing in response to your letter dated March 4, 2018, regarding certification testing of the Nova model wood stove, a prototype single burn rate wood stove manufactured by MF Fire. You are requesting to use alternative test procedures for recovery and preparation of the particulate matter (PM) samples from the front half filter and probe assembly. In particular, you propose use of the acetone probe rinse and filter sample recovery and preparation procedures described in sections 8.7 and 11.0 of Method 5, Determination of Particulate Matter Emissions from Stationary Sources (40 CFR 60, Appendix A), in lieu of the procedures in section 10.2.2 of ASTM E2515-11, Standard Test Method for Determination of Particulate Matter Emissions Collected by a Dilution Tunnel which is required under 40 CFR 60, Subparts AAA and QQQQ.

The difference between the sample recovery and preparation procedures of Method 5 and ASTM E2515-11 is that Method 5 determines PM in the probe and filter assembly by (1) collecting PM in the probe through acetone rinses of the probe, drying down the rinse in beakers, dessication, followed by weighing and (2) removal of the filter, dessicating, and then weighing, as opposed to ASTM E2515-11 where the entire 100+ gram probe assembly is weighed before and after a test run. We understand that ClearStak typically performs gravimetric analysis of their PM samples (acetone rinses and filters) at an offsite location and not in the wood heater emission testing laboratory to ensure quality low mass (e.g., milligram) measurements uninfluenced by ground vibrations caused by daily operations of testing facilities.

You state that through past experience, you have found that probe PM collected through acetone rinses which are then transported in sample jars offer far less possible sample contamination than handling the front half probe and filter assembly. You propose to collect the acetone rinses after testing according to section 8.7 of Method 5, transport them to your laboratory, then transfer the rinses from the jars to clean and desiccated pre-weighed 100 mL beakers where they are dried down and desiccated according to section 11.2.2 of Method 5, and finally weighed according ASTM E2515-11 in 6-hour intervals until two consecutive weights are achieved within 0.2mg. Likewise, the filters (which were pre-weighed before testing as required in section 8.1.3 of Method 5) are recovered according to section 8.7 of Method 5, transported to the laboratory, dessicated according to section 11.2.1 of Method 5, and weighed according ASTM E2515-11.

We understand ClearStak is requesting to use these alternative procedures for PM recovery, dry down, and desiccation of the front half probe and filter assembly samples for ASTM E2515-11 testing of MF Fire's prototype single burn rate stove, Nova, and for all future ASTM E2515-11 emissions testing of residential wood heaters, hydronic heaters, and forced-air furnaces per 40 CFR Part 60 Subparts AAA and QQQQ.

## Appendix 10

2

With this letter, we are approving your alternative test procedures detailed above in conjunction with ASTM E2515-11 for certification testing of the MF Fire's prototype single burn rate stove, Nova, as well as all wood heaters, hydronic heaters, and forced-air furnaces subject to 40 CFR Part 60 Subpart AAA and QQQQ. A copy of this letter must be included in each certification test report where this alternative test method is utilized.

It is reasonable that this alternative test method approval be broadly applicable to certification testing of all wood heaters, hydronic heaters, and forced-air furnaces subject to the requirements of 40 CFR part 60, Subparts AAA and QQQQ. For this reason, we will post this letter as ALT-126 on our website at <http://www3.epa.gov/ttn/emc/approalt.html> for use by other interested parties. This alternative method approval is valid until such time that Subparts AAA and QQQQ are revised or replaced to require a different certification method, and at such time, this alternative will be reconsidered and possibly withdrawn.

If you have additional questions regarding this approval, please contact Michael Toney of my staff at 919-541-5247 or [toney.mike@epa.gov](mailto:toney.mike@epa.gov).

Sincerely,

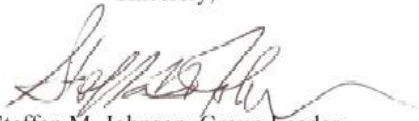

Steffan M. Johnson, Group Leader  
Measurement Technology Group

cc: Amanda Aldridge, EPA/OAQPS/OID  
Adam Baumgart-Getz, EPA/OAQPS/OID  
Rafael Sanchez, EPA/OECA  
Michael Toney, EPA/OAQPS/AQAD

Appendix 11

Calibrations

Calibration of manometer for dynamic pressure in dilution tunnel



KALIBRERINGSBEVIS

Datum  
2019-05-07  
Beteckning  
ETk9P00564-K02

Sida  
2 (3)

Tabell 1. Kalibreringsresultat Mätområde 0- 200 Pa.

Referens Verkligt tryck [Pa]	Objekt		
	Avläst tryck [Pa]	Korrektion [Pa]	Mätosäkerhet [Pa]
0,0	0,0	0,0	±0,31
2,0	2,0	0,0	±0,31
6,0	6,0	0,0	±0,31
10,1	10,0	0,1	±0,31
20,3	20,0	0,3	±0,31
30,2	30,0	0,2	±0,31
40,3	40,0	0,3	±0,31
50,3	50,0	0,3	±0,31
100,5	100,0	0,5	±0,31
150,9	150,0	0,9	±0,31
200,3	199,0	1,3	±0,41
0,0	0,0	0,0	±0,31
200,3	199,0	1,3	±0,41
0,0	0,0	0,0	±0,31
200,3	199,0	1,3	±0,41
0,0	0,0	0,0	±0,31

Calibration of manometer for static pressure in chimney



KALIBRERINGSBEVIS

Datum  
2019-09-24  
Beteckning  
ETk9P00564-K13

Sida  
2 (3)

Tabell 1.  
Kalibreringsresultat 0-200 Pa.

Referens Verkligt tryck [Pa]	Objekt		
	Avläst tryck [Pa]	Korrektion [Pa]	Mätosäkerhet [Pa]
0,0	0,0	0,0	±0,31
2,0	2,0	0,0	±0,31
5,9	6,0	-0,1	±0,31
10,0	10,0	0,0	±0,31
20,0	20,0	0,0	±0,31
30,1	30,0	0,1	±0,31
40,1	40,0	0,1	±0,31
50,1	50,0	0,1	±0,31
100,3	100,0	0,3	±0,31
150,7	150,0	0,7	±0,31
199,9	199,0	0,9	±0,41
0,0	0,1	-0,1	±0,31
199,9	199,0	0,9	±0,41
0,0	0,1	-0,1	±0,31
200,0	199,0	1,0	±0,41
0,0	0,1	-0,1	±0,31



Appendix 11

Calibration of gas meter sampling train 1



KALIBRERINGSBEVIS

Datum  
2019-06-18  
Beteckning  
ETk9P00564-K07

Sida  
2 (2)

Tabell 1. Kalibreringsresultat.

Referens	Objekt betingelser			Objekt			
	Verkligt flöde	Temperatur	Gasdensitet	Avläst volym	Avläst tid	Beräknat flöde	Korrektion
[m <sup>3</sup> /h]	[°C]	[kg/m <sup>3</sup> ]	[l]	[s]	[m <sup>3</sup> /h]	[%]	[%]
0.200	24.0	1.166	20.0	362.8	0.198	1.0	± 1.1
0.490	24.0	1.166	40.0	299.4	0.481	1.8	± 0.98
0.985	24.0	1.166	80.0	297.9	0.967	1.9	± 0.93
1.77	24.0	1.166	160.0	333.0	1.73	2.4	± 0.92
2.85	24.0	1.166	200.0	259.9	2.77	2.8	± 0.92

Kalibreringsgas: Luft

Angivna gasflöden avser volymflöden in i objektet vid aktuella kalibreringsbetingelser

$$\dot{V}_{\text{Beräknat}} = \frac{V_{\text{Avläst}}}{t}$$

$$\dot{V}_{\text{Verkligt}} = \dot{V}_{\text{Beräknat}} \cdot \left(1 + \frac{\dot{V}_{\text{Korrektion}}}{100}\right)$$

där

- $V_{\text{Avläst}}$  Avläst gasvolym
- $t$  Avläst mättid
- $\dot{V}_{\text{Beräknat}}$  Beräknat volymflöde
- $\dot{V}_{\text{Korrektion}}$  Korrektion vid beräknat volymflöde
- $\dot{V}_{\text{Verkligt}}$  Verkligt volymflöde

RISE Research Institutes of Sweden AB  
Energi och cirkulär ekonomi - Hållbara energisystem

Utfört av

Granskat av

*Harriet Standar*  
Signed by: Harriet Standar  
I am the author of this document  
2019-06-18 11:21:23 -02:00

*Fredrik Niklasson*  
Signed by: Fredrik Niklasson  
I have reviewed this document  
2019-06-18 13:24:15 -02:00

Harriet Standar

Fredrik Niklasson

Calibration of gas meter sampling trains 2 and 3



KALIBRERINGSBEVIS

Datum  
2019-06-18  
Beteckning  
ETk9P00564-K06

Sida  
2 (2)

Tabell 1. Kalibreringsresultat.

Referens	Objekt betingelser			Objekt			
	Verkligt flöde	Temperatur	Gasdensitet	Avläst volym	Avläst tid	Beräknat flöde	Korrektion
[m <sup>3</sup> /h]	[°C]	[kg/m <sup>3</sup> ]	[l]	[s]	[m <sup>3</sup> /h]	[%]	[%]
0.201	23.8	1.167	20.0	351.3	0.205	-1.9	± 1.1
0.494	23.8	1.167	40.0	286.8	0.502	-1.6	± 0.98
0.978	23.7	1.167	80.0	290.8	0.991	-1.2	± 0.93
1.68	23.7	1.167	140.0	297.8	1.69	-0.7	± 0.92
2.85	23.7	1.167	200.0	253.5	2.84	0.2	± 0.92

Kalibreringsgas: Luft

Angivna gasflöden avser volymflöden in i objektet vid aktuella kalibreringsbetingelser

$$\dot{V}_{\text{Beräknat}} = \frac{V_{\text{Avläst}}}{t}$$

$$\dot{V}_{\text{Verkligt}} = \dot{V}_{\text{Beräknat}} \cdot \left(1 + \frac{\dot{V}_{\text{Korrektion}}}{100}\right)$$

där

- $V_{\text{Avläst}}$  Avläst gasvolym
- $t$  Avläst mättid
- $\dot{V}_{\text{Beräknat}}$  Beräknat volymflöde
- $\dot{V}_{\text{Korrektion}}$  Korrektion vid beräknat volymflöde
- $\dot{V}_{\text{Verkligt}}$  Verkligt volymflöde

RISE Research Institutes of Sweden AB  
Energi och cirkulär ekonomi - Hållbara energisystem

Utfört av

Granskat av

*Harriet Standar*  
Signed by: Harriet Standar  
I am the author of this document  
2019-06-18 11:21:22 -02:00

*Fredrik Niklasson*  
Signed by: Fredrik Niklasson  
I have reviewed this document  
2019-06-18 13:24:15 -02:00

Harriet Standar

Fredrik Niklasson

Appendix 11

Calibration of gas meter blank probe (ambient)



KALIBRERINGSBEVIS

Datum  
2019-09-20  
Beteckning  
ETk9P00564-K11

Sida  
2 (2)

Tabell 1. Kalibreringsresultat.

Beräknat Verkligt flöde	Objekt betingelser		Objekt				
	Temperatur [°C]	Gasdensitet [kg/m³]	Avläst volym [l]	Avläst tid [s]	Beräknat flöde [l/min]	Korrektion [%]	Mätosäkerhet [%]
0,640	22,2	1,382	6,0	608,5	0,992	8,1	± 2,2
1,27	22,2	1,382	8,0	382,6	1,22	4,0	± 1,8
2,60	22,2	1,381	12,0	283,4	2,54	2,3	± 1,6
5,11	22,4	1,381	20,0	239,9	5,00	2,2	± 1,1
7,36	22,4	1,381	40,0	126,7	7,33	2,9	± 0,98
10,1	22,4	1,381	60,0	367,7	9,79	3,3	± 0,94

Kalibreringsgas: Luft

Angivna gasflöden avser volymflöden in i objektet vid aktuella kalibreringsbetingelser

$$V_{\text{Beräknat}} = \frac{V_{\text{Avläst}}}{t}$$

$$V_{\text{Verkligt}} = V_{\text{Beräknat}} \cdot \left( 1 + \frac{V_{\text{Korrektion}}}{100} \right)$$

där

$V_{\text{Avläst}}$  Avläst gasvolym  
 $t$  Avläst mättid  
 $V_{\text{Beräknat}}$  Beräknat volymflöde  
 $V_{\text{Korrektion}}$  Korrektion vid beräknat volymflöde  
 $V_{\text{Verkligt}}$  Verkligt volymflöde

RISE Research Institutes of Sweden AB  
 Energi och cirkulär ekonomi - Hållbara energisystem

Utfört av

Grunder av

*Henrik Stenlund*  
 Signed by: Henrik Stenlund  
 I have reviewed this document  
 2019-09-20 11:17:40.000

*Frank Nilsson*  
 Signed by: Frank Nilsson  
 I have reviewed this document  
 2019-09-20 11:31:27:40.000

Calibration of scale



KALIBRERINGSBEVIS

Datum  
2018-06-12  
Beteckning  
KVj1718 062

Sida  
2 (2)

Resultat

(Resultaten avser endast de föremål som är specificerade i detta dokument)

Före varje belastning har vågen nollställd

Efter intrinring med vågens inbyggda vikt

Belastning, g	Avläst på väg, g	Mätosäkerhet, ±g
5	5,00001	0,00001
20	20,00002	0,00003
40	40,00000	0,00005
60	60,00001	0,00006
80	80,00005	0,00007
150	150,0001	0,0002
200	200,0001	0,0002

Samtliga avlästa värden är angivna som medelvärde baserat på tre mätningar.

Excentriskt placerad last

Belastningspunkt	Belastning, g	Avläst på väg, g
1	100	99,9996
2	100	100,0000
3	100	99,9995
4	100	99,9995
5	100	100,0002



Mätosäkerhet

Den angivna utvidgade mätosäkerheten är produkten av standardmätosäkerhet och täckningsfaktor  $k = 2$ , vilket för en normalfördelning svarar mot en täckningssannolikhet av ungefär 95 %. Standardmätosäkerheten har bestämts i enlighet med EAL:s publikation EA-4/02.

RISE Research Institutes of Sweden AB  
 Kalibrering och Verifiering

Utfört av

*Niklas Sund*  
 Signed by: Niklas Sund  
 I am the author of this document  
 2018-06-21 07:40:54:002.000

Niklas Sund





Appendix 12

**Operating and installation manuals**

Please read carefully prior  
to installing and servicing.

SAVE THESE INSTRUCTIONS

# Operating Manual

Pellet heating with auger  
delivery or vacuum suction  
system for the end-user

**AutoPellet®**  
**PE(S)(K)(B) 10 – 56**

---

FA\_V2.03

AutoPellet TOUCH

---

USA



Title: Operating Manual **AutoPellet**<sup>®</sup> PE(S)(K)(B) 10 –  
Article number: 56 PE 568 USA 1.1  
  
Version valid from: 04/2015  
Approved: Wohlinger Christian

## Author & Manufacturer

MAINE ENERGY SYSTEMS LLC  
8 Airport Road – P.O. Box 547 Bethel  
Maine 04217

E-Mail: [info@maineenergysystems.com](mailto:info@maineenergysystems.com)  
[www.maineenergysystems.com](http://www.maineenergysystems.com)

© MAINE ENERGY SYSTEMS LLC  
Subject to modifications

<b>1</b>	<b>Dear Customer</b> .....	<b>5</b>
<b>2</b>	<b>Use only for the purpose intended</b> .....	<b>6</b>
<b>3</b>	<b>Types of safety warning sign</b> .....	<b>7</b>
<b>4</b>	<b>Warnings and safety instructions</b> .....	<b>8</b>
4.1	Basic safety instructions .....	8
4.2	Warning signs.....	8
4.3	What to do in an emergency.....	10
<b>5</b>	<b>Prerequisites for installing a pellet boiler</b> .....	<b>11</b>
5.1	Guidelines and standards for installing a pellet boiler .....	11
5.2	Boiler room.....	11
5.3	Flue gas system.....	12
5.4	Safety systems .....	15
5.5	Installation with an existing boiler.....	16
<b>6</b>	<b>Fuel</b> .....	<b>17</b>
6.1	Specification for high quality pellets as PFI (Pellet Fuel Institut) .....	17
6.2	Storing the pellets .....	18
6.3	Measures for the ventilation of storage rooms .....	18
<b>7</b>	<b>Product description</b> .....	<b>19</b>
7.1	The pellet boiler .....	20
7.2	Pellet suction system.....	22
7.3	Auger delivery system .....	22
7.4	Storage systems.....	23
	7.4.1 Pellet storage room.....	23
	7.4.2 Flexilo fabric tank.....	23
<b>8</b>	<b>Operating the Pellematic</b> .....	<b>24</b>
<b>8.1</b>	<b>Operating the heating system</b> .....	<b>24</b>
8.2	Description of the control panel .....	24
8.3	Setting language, date and time at Pelletronic Touch.....	25
<b>9</b>	<b>Pelletronic heating controller and operating device with touch screen</b> .....	<b>27</b>
9.1	Operating Device with Touch screen .....	27
9.2	Opening window .....	27
9.3	User controls and their function .....	28
9.4	Main Menu .....	30
<b>10</b>	<b>Mode</b> .....	<b>32</b>
<b>11</b>	<b>Measuring Values</b> .....	<b>33</b>
<b>12</b>	<b>Weather</b> .....	<b>34</b>
<b>13</b>	<b>Eco Mode</b> .....	<b>35</b>
<b>14</b>	<b>Heating Circuit</b> .....	<b>36</b>
14.1	Measuring values Heating circuit.....	37
14.2	Time programme Heating circuit.....	38
14.3	Party.....	39
14.4	Vacation.....	39
14.5	Heating curve and Heating limits.....	40
<b>15</b>	<b>Domestic hot water</b> .....	<b>43</b>
15.1	Measuring values Domestic hot water.....	44
15.2	Time programme DHW .....	44
<b>16</b>	<b>DHW Return pump</b> .....	<b>45</b>
16.1	Measuring values DHW Return pump.....	46
16.2	Time programme DHW return pump .....	46
<b>17</b>	<b>Solar</b> .....	<b>47</b>
17.1	Measuring values Solar.....	47
17.2	Solar circuit.....	48
17.3	Yield - Solar Energy.....	49
<b>18</b>	<b>Pellematic</b> .....	<b>50</b>
18.1	Measuring values.....	50



18.2 Full Power..... 51

18.3 Boiler cleaning..... 52

18.4 Level detection system..... 53

18.5 Suction turbine..... 54

**19 General..... 55**

19.1 Chimney ..... 55

19.2 Favorite ..... 56

19.3 Local Settings..... 57

19.4 Malfunction ..... 58

19.5 Information..... 58

19.6 ModBUS ..... 59

19.7 E-Mail..... 60

19.8 IP Config..... 61

**20 Software ..... 64**

**21 Emptying the ash pan ..... 65**

**22 Emptying the ash box ..... 66**

**23 Maintenance and servicing ..... 68**

23.1 Maintenance ..... 68

23.2 Cleaning the boiler every year..... 69

23.3 Maintenance intervals ..... 73

23.4 Repairs ..... 73

23.5 Checking the boiler room and storage room..... 73

# 1 Dear Customer

**Maine Energy Systems** specializes in wood pellet heating, our company enjoys an exclusive license from ÖkoFEN to manufacture **AutoPellet** boilers here in the USA. We represent expertise, innovation and quality. We are delighted that you have decided to purchase our product.

- This instruction manual is intended to help you operate the product safely, properly and economically.
- Please read this instruction manual completely and take note of the safety warnings.
- Keep all documentation supplied with this unit in a safe place for future reference.  
Please pass on the documentation to the new user if you decide to part with the unit at a later date.
- Installation and first start up must be carried out by an installer certified by Maine Energy Systems.
- Please contact your authorised dealer if you have any questions.

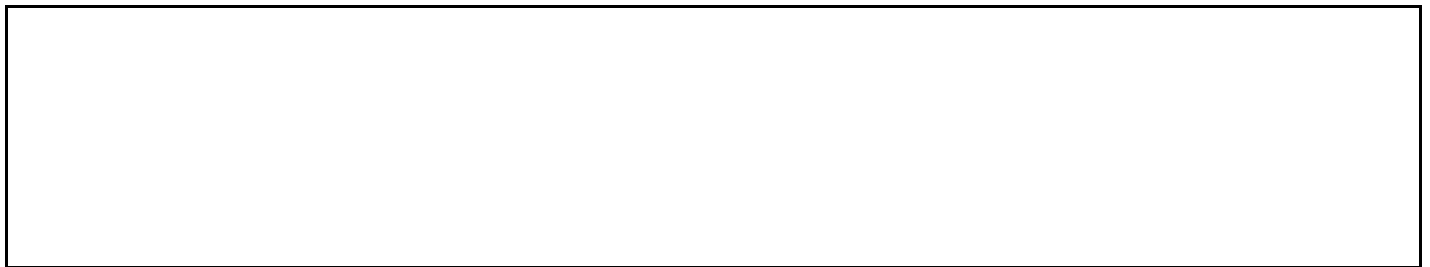

We place great importance on the development of new products. Our R&D department continues to question accepted solutions and works continually on new improvements. That is how we maintain our technological lead. We have already received several awards for our products in Austria and abroad. Our products fulfil European and USA requirements regarding quality, efficiency and emissions.



## **2 Use only for the purpose intended**

The pellet boiler is designed to heat water for central or other indirect heating systems and hot water supply for buildings. It is not permissible to use the pellet boiler for any other purpose. Reasonable foreseeable inadvertent uses for the pellet boiler are not known.

The boiler fulfils the requirements of UL 2523-2013 and CSA B366.1-2011.

### 3 Types of safety warning sign

The warning signs use the following symbols and texts.

#### Types of safety warning sign

1. Risk of injury
2. Consequences of risk
3. Avoiding risk



#### 1. Risk of injury:

Danger - indicates a situation that could lead to death or life-threatening injury.



Warning - indicates a situation that could lead life-threatening or serious injury.



Caution - indicates a situation that could lead to injury.



Note - indicates a situation that could lead to property damage.



#### 2. Consequences of risk

Effects and consequences resulting from incorrect operation.

#### 3. Avoiding risk

Observing safety instructions ensures that the heating system is operated safely

## 4 Warnings and safety instructions

Observing safety instructions ensures that the heating system is operated safely.

### 4.1 Basic safety instructions

- Never get yourself into danger; give your own safety the utmost priority.
- Keep children away from the boiler room and storage room.
- Observe all safety warnings on the boiler and in this user manual.
- Observe all instructions relating to maintenance, servicing and cleaning.
- The pellet heating system may only be installed and started up for the first time by an authorised installer. Professional installation and start up is the prerequisite for safe and economical operation.
- Never make any changes to the heating system or flue gas system.
- Never close or remove safety valves.

### 4.2 Warning signs

 <b style="font-size: 1.5em; margin-left: 10px;">DANGER</b>
<p><b>Risk of poisoning</b>          Make sure that the pellet boiler is supplied with sufficient combustion air.          The openings in the combustion air inlet must never be partially or completely closed.          Ventilation systems, central vacuum cleaning systems, extractor fans, air conditioning systems, flue gas blowers, dryers, fuel storage ventilation fans or similar equipment must never be allowed to draw air from the boiler room and cause a drop in pressure.          The boiler must be connected tight to the chimney using a flue gas tube.          Clean the chimney and the flue gas tube at regular intervals.          The boiler room and pellet storage room must be sufficiently supplied with air and ventilated.          Before entering the storage room it must be ventilated with sufficient air and the heating system switched off</p>

 <b style="font-size: 1.5em; margin-left: 10px;">DANGER</b>
<p><b>Risk of electric shock</b>          Only an authorised installer may connect the pellet boiler to the power supply.          Always disconnect / de-energize the power supply before working on the boiler.</p>

 <b style="font-size: 1.5em; margin-left: 10px;">DANGER</b>
<p><b>Risk of explosion</b>          DO NOT BURN GARBAGE, GASOLINE, NAPHTHA, ENGINE OIL, OR OTHER INAPPROPRIATE MATERIALS.          DO NOT USE CHEMICALS OR FLUIDS TO START THE FIRE.          Switch off the heating system before filling the storage room.</p>



## DANGER

### Risk of fire

Do not store any flammable materials in the boiler room.  
Do not hang out any washing in the boiler room.  
Do not operate with fuel loading or ash removal doors open.



## WARNING

### Risk of burns

Do not touch the flue gas connector or flue gas pipe.  
Do not reach into the ash chamber.  
Use gloves to empty ash box if boiler not equipped with automatic ash compression  
Do not clean the boiler until it has been allowed to cool down.



## CAUTION

### HOT SURFACES

Keep children away.  
Do not touch during operation.  
Do not operate if maximum draft as listed on boiler nameplate is exceeded.  
Doing so can allow non-controlled combustion.



## CAUTION

### Risk of cut injuries due to sharp edges.

Use gloves for performing all work on the boiler.

## NOTICE

### Damage to property

The pellet boiler is suitable only for pellets which comply with PFI premium or EnPlus -A1 pellets specifications.  
The use of any other fuel voids your warranty and can cause damage to the pellet boiler and chimney.

## NOTICE

### Damage to property

Do not use the heating system if it, or any of its components, come into contact with water.  
If water damage occurs, check the heating system by an authorized service technician and replace damaged parts.



## WARNING

All cover plates, enclosures, and guards must be maintained in place at all times, except during maintenance and servicing.

## 4.3 What to do in an emergency



### DANGER

**Risk to life**

Never get yourself into danger; give your own safety the utmost priority.

**What to do in the event of a fire**

- Switch off the heating system.
- Call your local fire department and or 911.
- Use approved fire extinguishers (fire protection class ABC).

**What to do if you smell smoke**

- Switch off the heating system.
- Close the doors leading to living areas.
- Ventilate the central heating room.

## 5 Prerequisites for installing a pellet boiler

You must fulfill the following conditions before operating a fully automatic pellet boiler.

### 5.1 Guidelines and standards for installing a pellet boiler

Overview of standards and guidelines applying to the installation of a pellet boiler.

Check whether you need to obtain planning permission or approval from the authorities for installing a new heating system or changing your existing system. Legislation in your country must be observed.

Flue gas system	EN 13384-1	Legislation in your country must be observed.
Building and fire prevention regulations		Legislation in your country must be observed.
Type of installation	FC 42x	Fireplace with a flue gas fan for connection to an air exhaust system. The combustion air line from air shaft and the connecting piece to the chimney are part of the fireplace.
	FC 52x	Fireplace with a flue gas for connection to a chimney. The combustion air line from outside and the connecting piece to the chimney are part of the fireplace.
Sound insulation	DIN 4109	Please note the building-unique demands on sound insulation.

### 5.2 Boiler room

The pellet boiler is installed in the boiler room.

#### 1. Safety instructions for the boiler room

DANGER

**Risk of fire**  
 Do not store flammable materials or liquids in the vicinity of the pellet boiler.  
 Do not permit unauthorised persons to enter the boiler room - Keep children away.  
 Do not operate with fuel loading or ash removal doors open.

#### 2. Air supply and ventilation of boiler room

The boiler room must be fitted with air supply and ventilation openings (at least 31 inch<sup>2</sup>/200cm<sup>2</sup>). In any case you must comply with the state and local regulations

#### 3. Combustion air supply

The pellet boiler needs a supply of combustion air. The supply of combustion air can:

- a. take place using one or more air supply and ventilation openings in total min. 31 inch<sup>2</sup>.
- b. or through a special air supply line directly from outside, where the diameter of the air supply line must be at least 4 inch/ 100mm in for type PE(S) 12 - PE(S) 32. Ambient air independent operation of PES 36-56 types is also available on request. In any case, properly sized room ventilation is still required to allow your barometric draft controller to function properly.

Never operate the pellet boiler if the air intake openings are partially or completely closed.

Contaminated combustion air can cause damage to the pellet boiler. Never store or use cleaning detergents containing chlorine, nitrobenzene or halogen in the room where the heating system is installed, if combustion air is drawn directly from the room. It is recommended that no washing or drying of laundry is done in the boiler room or where the boiler may draw air from.

Do not hang out washing in the boiler room.



Prevent dust from collecting at the combustion air intake to the pellet boiler.

#### 4. **Damage due to frost and humid air**

The boiler room must be frost-proof to ensure trouble-free operation of the heating system. The temperature of the boiler room must not fall below 37°F and must not exceed 90°F. The air humidity in the boiler room must not exceed 70%.

#### 5. **Danger for animals**

Make sure that household pets and other small animals cannot enter the boiler room. Fit mesh over any openings.

#### 6. **Flooding**

If there is a risk of flooding, switch off the pellet boiler and disconnect from the power supply before water enters the boiler room. You must have all components that come into contact with water replaced, before you start up the pellet boiler again.

## 5.3 Flue gas system

The flue gas system consists of a chimney and a flue gas tube. The flue gas tube connects the pellet heating system to the chimney. The chimney leads the flue gas from the pellet heating system out into the open.

### 1. **Design of the chimney**

The dimensions and design of the chimney is very important. The chimney must be able to ensure sufficient draft to safely draw away the flue gas regardless of the status of the boiler. Low flue gas temperatures can cause sooting and moisture damage on chimneys that are not insulated. For this reason **moisture-resistant chimneys** (stainless steel or ceramic) should be used. An existing chimney that is not damp-resistant needs to be renovated before use. Follow guidelines below:

Boiler size		PE(S) 12 - 20	PE(S) 25 - 32	PE(S) 36 - 56
Flue gas tube diameter (at boiler)	inch/mm	5/130 or 6/150	6/150	7/180
Flue gas temp. / rated power	°F	320	320	360
Flue gas temp. / partial load	°F	212	212	230
Min. draft - full load/part load	in/wc	-0.04 / -0.02		

Chimney size	Min. Height
6in x 6in	17ft
7in x 7in	16ft
8in x 8in	16ft
6in round	19ft
7in round	17ft

## NOTICE

Person(s) operating a hydronic heater is/are responsible for operation in a manner that does not create a public or private nuisance condition. The manufacturer's distance and stack height recommendations and the requirements in any applicable laws or other requirements may not always be adequate to prevent nuisance conditions due to terrain or other factors.

Recommended and UL-103HT approved chimney materials are:

- a. Selkirk sure temp

- b. Supervent (JSC)
- c. Security chimneys (secure temp ASHT)

Use flue gas pipe from chimney to boiler as required by your local code.



## CAUTION

### Unregulated combustion

Please observe that combustion air openings and flue pipes are not reduced in size or closed. Make end user aware of these guidelines and their potential danger.

Clean the chimney and the flue gas tube at regular intervals.

Check if the draft inducer is clean and in a good condition.

## 2. Flue gas temperature

The flue gas temperatures are approximately the same for all **AutoPellet** boilers covered in this manual.

The dewpoint of flue gas with wood pellets (max. 10% water content) is approx. 120°F.

It is possible to increase the flue gas temperature to prevent condensation inside the chimney and avoid damage due to damp. Only authorised installers may increase the flue gas temperature.

### Note:

The increase in flue gas temperature results in reduced efficiency and thus increases fuel consumption.

## 3. Negative pressure of the chimney

The boiler must be connected to a chimney or a vertical venting system that is capable of handling and producing a negative breeching pressure of  $-0.4$  "WC. Use a draft gauge to verify the indicated draft value, adjust barometric damper as required. Drill a small hole in the connection pipe at about 2in/ 50mm from the boiler flue outlet and use this hole as your measuring point.

### Chimney draft

The suction effect of the chimney draft must extend all the way to the boiler flue pipe connection. The maximum flow rate that can be drawn through the chimney limits the maximum performance of the chimney connection. The boiler performance must be reduced if the chimney does not possess the necessary cross-section. This may only be performed by authorised personnel.

## 4. Power venter

AutoPellet boilers are approved by the manufacturer for installation with the Field Controls SWGAF power venter which is approved for wood pellet burning appliances.

Boilers installed with SWGAF power venters must follow all manufacturer's installations and must comply with all applicable codes from agencies having authority over the installation.



## 5. Cleaning

Clean the flue gas tube and chimney regularly. Solid fuel burning appliances need to be cleaned frequently because soot, creosote, and ash may accumulate. The hotter the fire, the less creosote is deposited. Cleaning intervals can vary in warm periods due to this and become more frequent.



## DANGER

### Risk of chimney fire

Creosote-formation and need for removal: Low flue gas temperature can cause creosote. Creosote can condense in a relatively cool chimney. As a result, creosote residue accumulates on the flue lining. If ignited, this creosote will create an extremely hot fire. The chimney and the chimney connector should be inspected at least twice monthly during the heating season to determine if a creosote buildup has occurred. If creosote has accumulated it should be removed to reduce the risk of a chimney fire.

## NOTICE

### Oxidation of chimney

Do not use metal brushes to clean chimneys made of stainless steel.

Your state and local regulations must be observed.

## 5.4 Safety systems

The following safety measures are the prerequisite for safe operation of your system.

### Emergency stop switch

Every heating system must be able to be switched off with an Emergency Stop switch. The Emergency Stop switch must be outside of the boiler room.



### Safety valve

The hydronic system must be equipped with a safety valve. This valve opens before the pressure inside the heating system increases to max. 43 P.S.I.. The safety valve must be installed at the highest point of the boiler, must not be locked and must be within 3.28 ft / 39.37 inch/ 1m of the boiler. A 30 lb/sq in relief value is supplied with each boiler.



### Safety temperature sensor

The pellet boiler is equipped with a safety temperature sensor. This is located on the pellet boiler. If the boiler temperature exceeds 230°F then the heating system switches off.



### Low water cut off

The hydronic system must be equipped with a low water cut off. If the water level falls below a certain level, the low water cut off switches off the heating system.



## NOTICE

### Initial start-up

The initial start-up of each pellet boiler must be performed by an authorized installer.

## 5.5 Installation with an existing boiler

Autopellet boilers are not to be connected to a chimney flue serving another appliance. However, when all State and local codes allow for the sharing of chimney flues, the Autopellet boilers and another appliance burning pellets or a different fuel can be operated simultaneously while connected to a single existing chimney or flue gas system providing the following conditions are met:

- All state and local codes permit the specific installation
- All appliances are installed in accordance with the manufacturer's installation specifications or if lacking manufacturers specifications, the appliance in question is installed in a manner commonly recognized as safe and correct for the application and circumstances
- The chimney or flue gas system must be able to handle the combustion products of either appliance and both appliances when operated simultaneously

### NOTICE

#### Avoid clearance issues that can make servicing difficult:

Be sure to follow suggested clearances when installing the Autopellet boiler with an existing boiler to be sure that service and cleaning can be performed adequately.



### CAUTION

#### Avoid code violations:

When connecting to or with an existing boiler, contact the authority having jurisdiction to be sure the type of installation planned is allowed.

Document the type of boiler that the Autopellet is connected to or with.

Pellet boiler: Make and Model number: \_\_\_\_\_

Existing boiler: Make and Model number: \_\_\_\_\_



### DANGER

#### Possible escape of flue gas:

Do not connect this unit to a chimney flue serving another appliance unless multiple appliances into a single flue is authorized by all authorities having jurisdiction.

## 6 Fuel

Wood pellets are natural wood (dried sawdust or waste from machining) that has been formed into pellets under high pressure. They have a very low moisture content and very high calorific value. The manufacture of wood pellets is regulated by European standard EN 14961-2.

### 6.1 Specification for high quality pellets as PFI (Pellet Fuel Institut)

Calorific value	min. 7200 BTU/lbs
Bulk density	min. 40 Lb/cft
Water content	max. 10%
Ash content	max. 1.0%
Ash melting point	at least 2192°F
Length	max. 1.5 inch / 40 mm
Diameter	1/4" - 5/16" / 6 - 8mm
Fine material	max. 0.5 %
Contents	100% untreated natural wood

### NOTICE

The pellet boiler is suitable only for pellets of natural wood that comply with PFI premium specifications. Using non-pelletised fuels or pellets that are not manufactured from natural wood will lead to the warranty becoming void and will cause damage to the pellet boiler and the chimney.



### WARNING

Never use pellets that contain treated wood, colored paper products, cardboard, solvents, plastic, trash or garbage  
 Never burn trash, plastics, gasoline, solvents, naphtha, household garbage, material treated with petroleum products such as particleboard, railroad ties and pressure treated wood, leaves, paper products, cardboard.

## 6.2 Storing the pellets

1. Pellets are to be stored in a place where they are kept dry all year.
2. Install a back-ventilated partition to prevent pellets from contacting damp walls, or use a fabric tank.
3. Refer to our planning hints for pellet storage rooms and warning signs.
4. Legislation in your country must be observed regarding building specifications for storage rooms.
5. ÖkoFEN also offers FleXILO fabric tanks for storing pellets.

## 6.3 Measures for the ventilation of storage rooms

To avoid any kind of danger through possible degassing of the pellets, make sure you obey the following guidelines:

- The storage room has to be insulated towards the living area.
- The storage room has to be ventilated into open area.

For further information please consult your expert adviser.

## 7 Product description

The description of the product is intended to provide an overview of the components that make up an ÖkoFEN pellet heating system, the parts of the pellet boiler and advice on where you can find more information.

The ÖkoFEN concept features different sizes of design and type for each component. These are compatible and designed to match.

**The ÖkoFEN pellet heating system consists of 3 components**

1	Pellematic pellet boiler
2	Conveyor system
3	Storage system - storage room or fabric tank

**Pellet boiler with storage room**

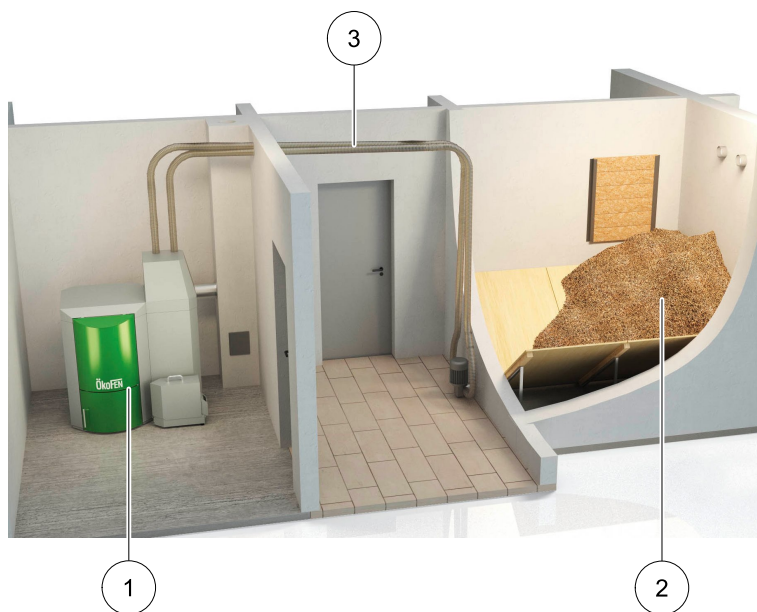

**Pellet boiler with fabric tank**

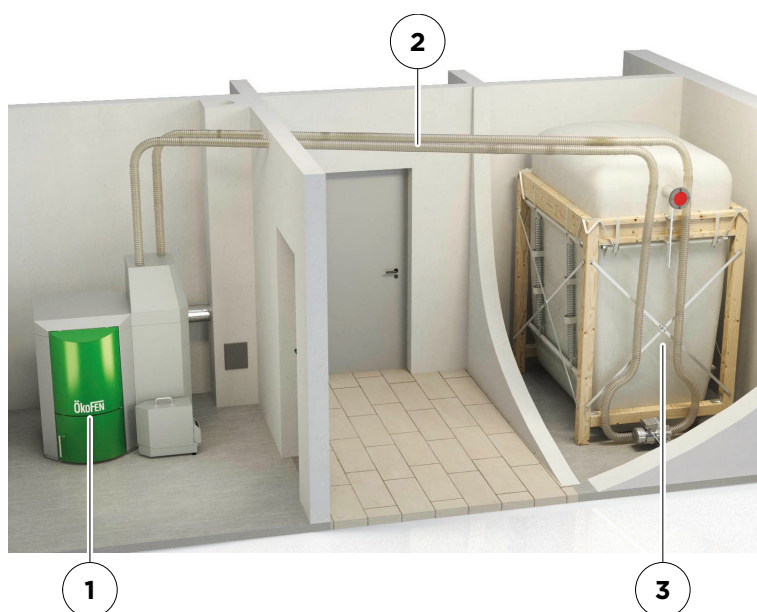



## 7.1 The pellet boiler

The pellet boiler is equipped with an automatic cleaning system, an ash box with ash compression system and an integrated return water temperature control. The installed programmable logic controller system enables fully automatic operation and highest efficiency. We offer an optional automatic de-ashing system for the highest level of cleanliness and comfort.

### Pellematic types and power ratings

We offer the Pellet boiler with the following power ratings:

Suction-feed systems: 41,000; 51,000; 68,300; 85,300; 109,500; 123,000; 164,000 and 191,000 BTU/hr

All sizes / outputs of the Autopellet boiler are available with external automatic ash compression system.

**Note:**

Refer to the data plate for the power rating of your **AutoPellet**. The data plate is located on the rear side of the Pellematic. Here you will find the type designation, manufacturer's serial number and year of build.

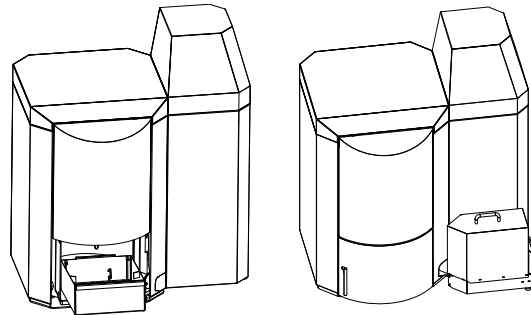

### Key components of the Pellematic

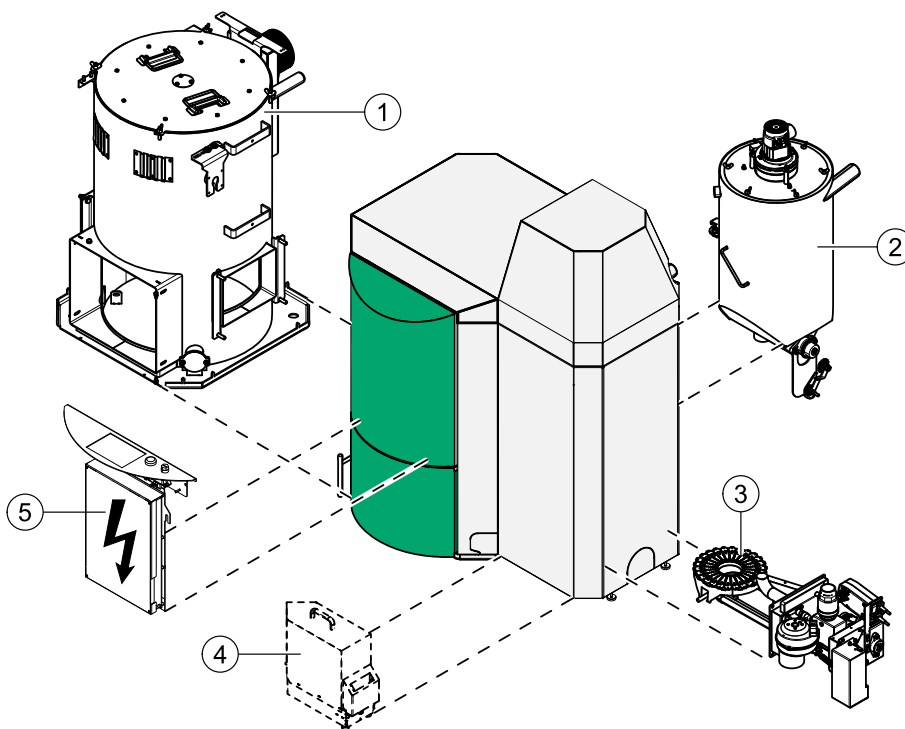

1	Boiler (heat exchanger)
2	Vac Hopper / Day tank
3	Burner
4	External automatic ash compression system
5	Boiler controller

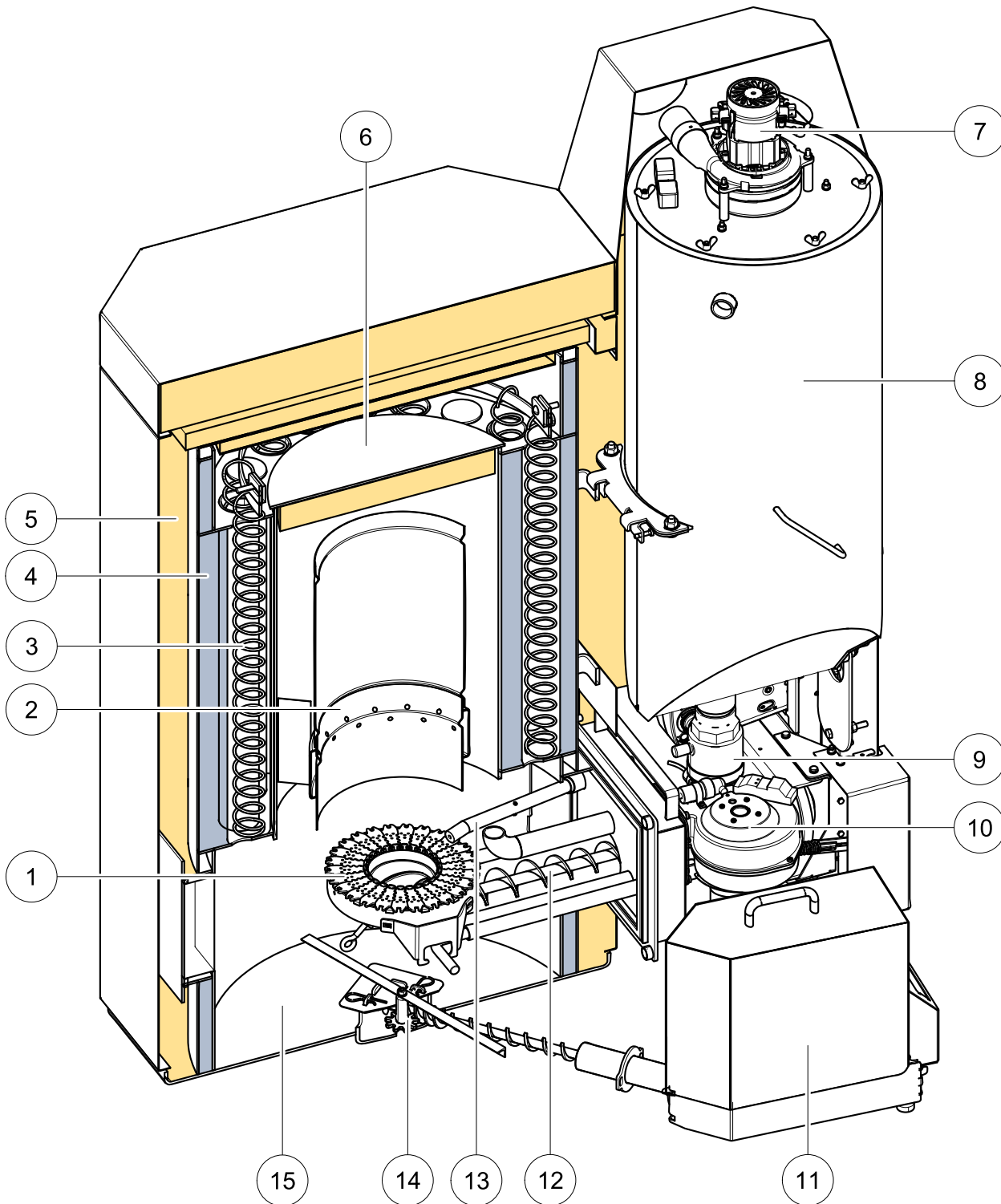

1	Burner plate	9	Fire protection - ball valve
2	Flame tube	10	Burner fan
3	Heat exchanger	11	External ash box
4	Boiler water	12	Burner auger
5	Boiler insulation	13	Electronic ignition
6	Combustion chamber cover	14	De-ashing system
7	Suction turbine	15	Ash chamber / Fire chamber
8	Vac hopper / Day tank		

## 7.2 Pellet suction system

The pellet suction system consists of the pellet line, air line and a suction fan. The suction fan in the hopper conveys pellets in the pellet line from the storage room or fabric tank to the hopper.

### Key components of pellet suction system

1	Pellet line	Line from the storage room auger or fabric tank to the hopper.
2	Air line	Line from the suction fan to the storage room auger or fabric tank.
3	Suction fan	Located above the hopper behind the Pellet boiler burner housing.
4	T-piece	Located at front end of the storage room auger, outside the storage room.
5	Suction flap	Located underneath the fabric tank.

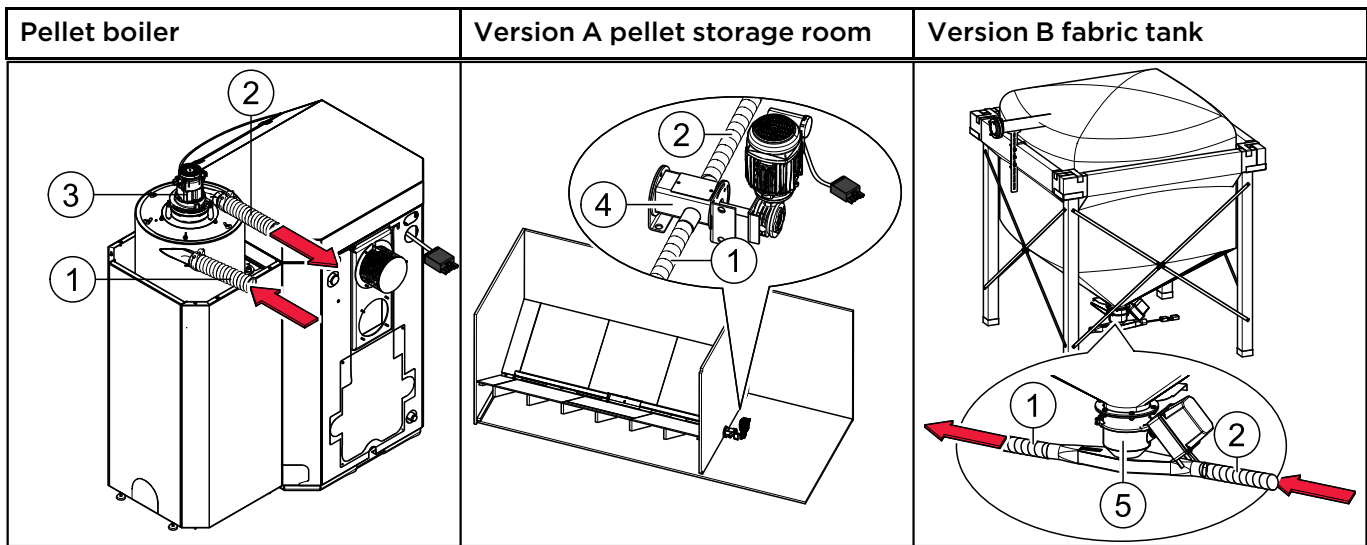

## 7.3 Auger delivery system

The auger system consists of: Delivery system motor, dropshaft, up leading auger with joint or extraction auger with extraction unit. The delivery system motor powers the auger system and transports pellets from the tank room or textile tank to the burner plate.

### Key components of the auger system

1	Up leading auger	Delivery auger with motor unit and joint (Connection of delivery auger and pellet boiler)
2	Extraction auger	Delivery auger with auger, emergency gate, supporting leg and handcuffs; (Connection of textile tank and pellet boiler)

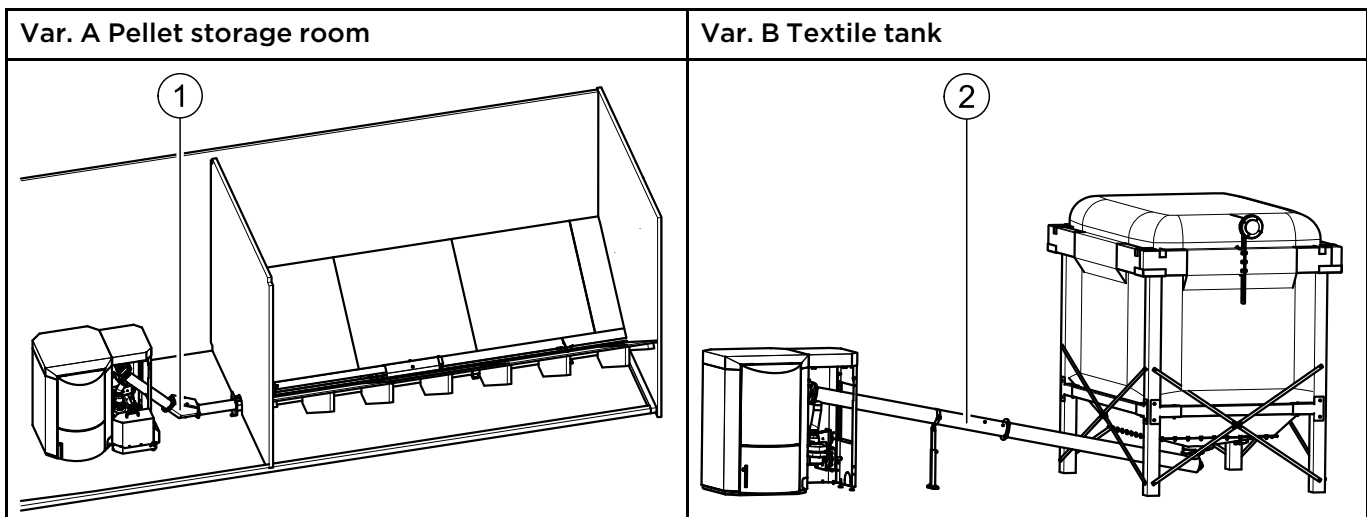

## 7.4 Storage systems

There are two methods for storing pellets: in a storage room with an auger feed system (version A) or in a FleXILO fabric tank (version B). FleXILO fabric tanks can be located inside the central heating room, storage room or protected from wet and sun outside.

### NOTICE

#### **Damage to property and loss of warranty**

The combination of an ÖkoFEN pellet boiler with a storage and conveyor system from another manufacturer is not permissible.

#### **7.4.1 Pellet storage room**

The auger extraction system is part of the ÖkoFEN pellet heating system. The sloping base is to be provided by the customer. Information and important notes on setting up storage rooms can be found in the ÖkoFEN planning documents and on [www.oekofen.com](http://www.oekofen.com). Information on installing the auger extraction system is included in the auger system installation manual. Refer to the instructions on how to make a sloping base.

#### **7.4.2 Flexilo fabric tank**

The whole fabric tank system is included in the scope of supply. ÖkoFEN offers various sizes and types. The fabric tank supplied may vary from the example shown above.

Please refer to the installation instructions supplied for the fabric tank. Note also the instructions on setting up and filling.

## 8 Operating the Pellematic

The pellet heating system is an automatic heating system. All pellet feed system and combustion system sequences are regulated automatically using an electronic boiler controller and heating controller.

### 8.1 Operating the heating system

#### NOTICE

Damage caused do to incorrect operation or incorrect settings.

Only trained operators may use the heating system. Make sure no unauthorised persons enter the central heating room. Keep children away from the central heating room and storage room.



#### DANGER

**Fire risk**

Keep the ash removal door closed while the boiler is in operation.

#### NOTICE

**Standby mode boiler controller**

Don't set the main switch of the boiler controller outside of the heating period to Off, because no buffer battery is used.

### 8.2 Description of the control panel

The control panel is located underneath the flap above the door of the boiler.

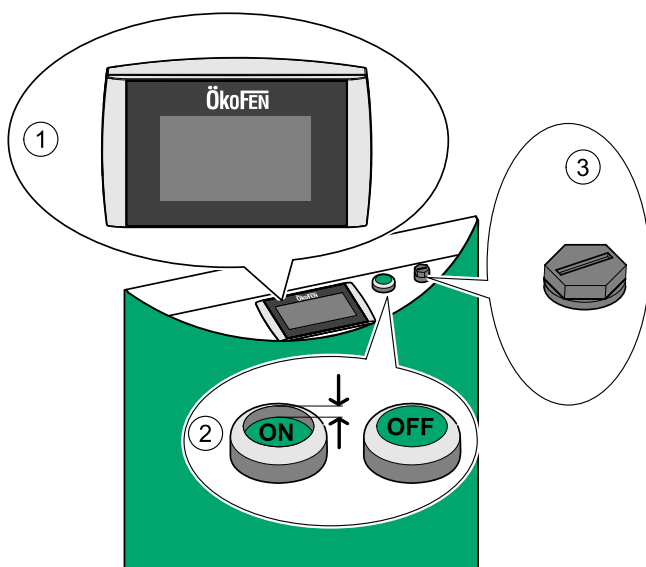

1	User control unit	Operates the boiler controller and the heating controller.
2	Main switch	Switches off the heating system (both poles) including the power supply to the control panel.
3	Safety temperature sensor	Switches the heating system off, if the boiler temperature reaches 203 °F. The heating controller remains active.

## 8.3 Setting language, date and time at Pelletronic Touch

**Setting the language** (The factory setting for the language is German)



### Setting the date

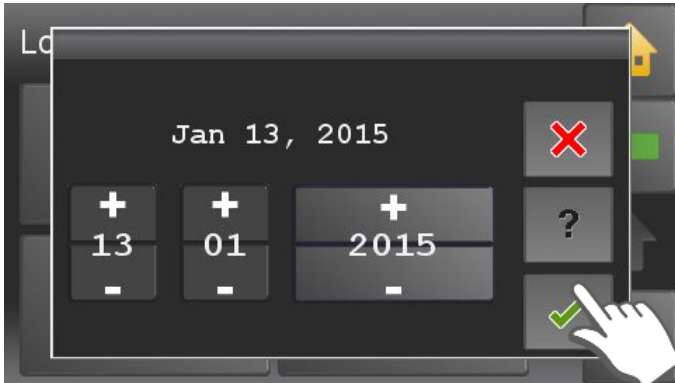

### Setting the time



## 9 Pelletronic heating controller and operating device with touch screen.

The heating controller regulates the heating system, the operating modes, heating circuits, domestic hot water, accumulator, existing boiler and the solar thermal system. All inputs and outputs are connected with the heating controller. Visualization and operation of the heating controller is done with the operating device with touch screen. It displays all menu options and measuring values of the heating controller. All specific settings of the heating system are done with the Touch operating device.

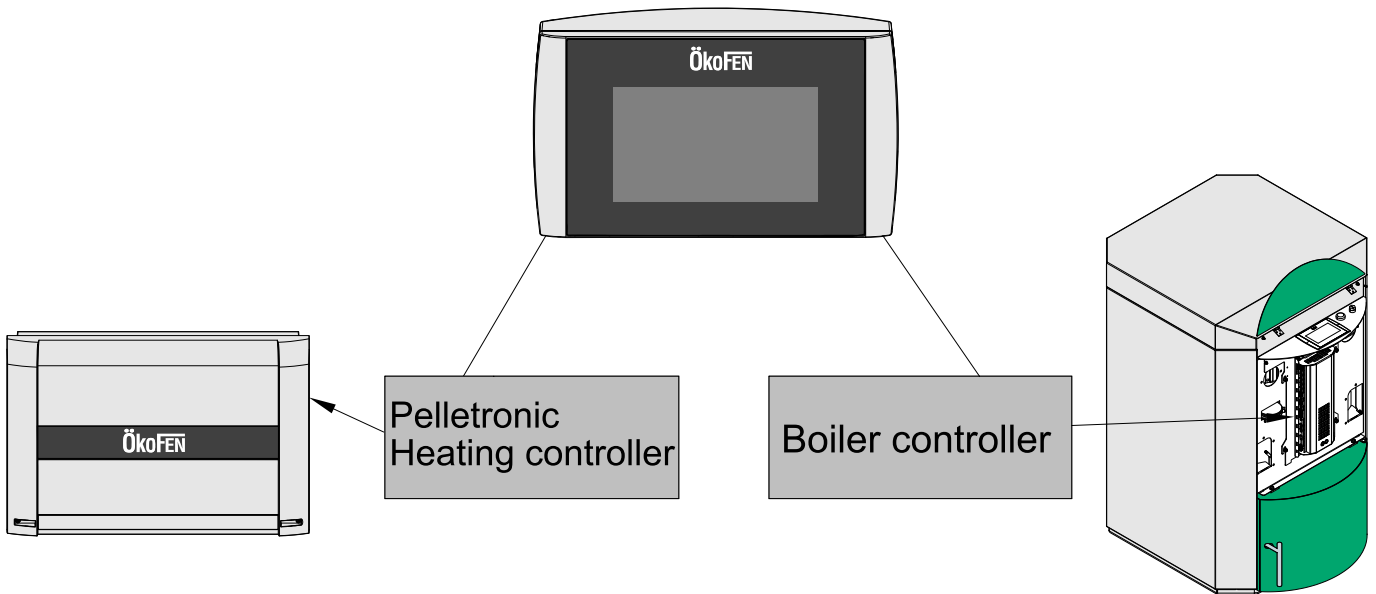

### 9.1 Operating Device with Touch screen

The Touch operating device is mounted on the control board of **AutoPellet**. The 4.7" color display is surrounded by a foil design with logo. With finger pressure you make settings on the Touch operating device.

### 9.2 Opening window

The touch panel is dark during in standby mode. As soon as you touch the surface of the touch, light turns on and displays the opening window.

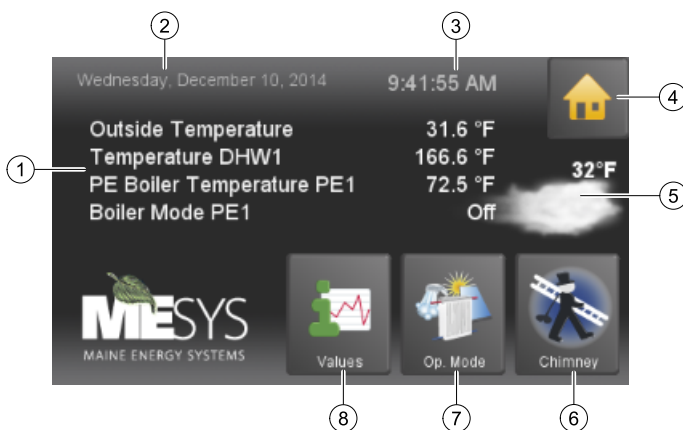

- 1 Measuring values (adjustable)
- 2 Date
- 3 Hour
- 4 The icon house takes to the main menu
- 5 Weather
- Note:**  
If there is a malfunction, the corresponding fault message is displayed at this point instead of the weather icon
- 6 Favorite 1 (adjustable)
- 7 Favorite 2 (adjustable)
- 8 Favorite 3 (adjustable)



## 9.3 User controls and their function

### 1. Navigation-icons

Icon-  
view

If you touch an icon, the icon turns green. The green shows that you are currently on this icon. You get to the enabled menu item .



The yellow house enters you directly to the main menu.



The horizontal arrow leads you one step back.



With the blue down arrow you get to additional lines of information on this item. (Down - scroll down).



With the blue up arrow you get to additional lines of information on this item. (Top of page - scroll up)



You get to the respective menu item.

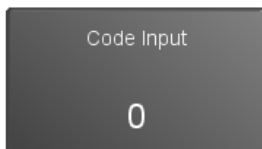

You get to the settings of the parameter. You come either to a numeric keypad, a time / date block or the text selection.

2. Numeric keyboard

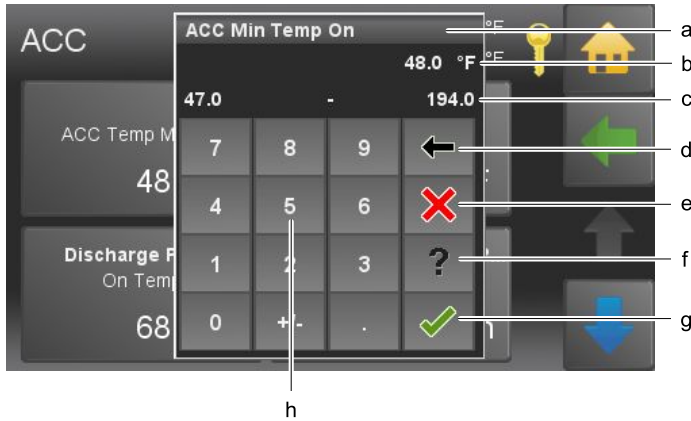

- a. Name of parameter
- b. Value of parameter with unit
- c. Min/max value - Values outside this range are not accepted.
- d. Delete input of numbers - per contact you delete one place.
- e. Cancel - You return to the menu item. Input of a new value was not accepted. The original value is.
- f. Help function - inactive
- g. Confirm
- h. Numeric keyboard - used to enter values within the min - max range.

3. Time and date block

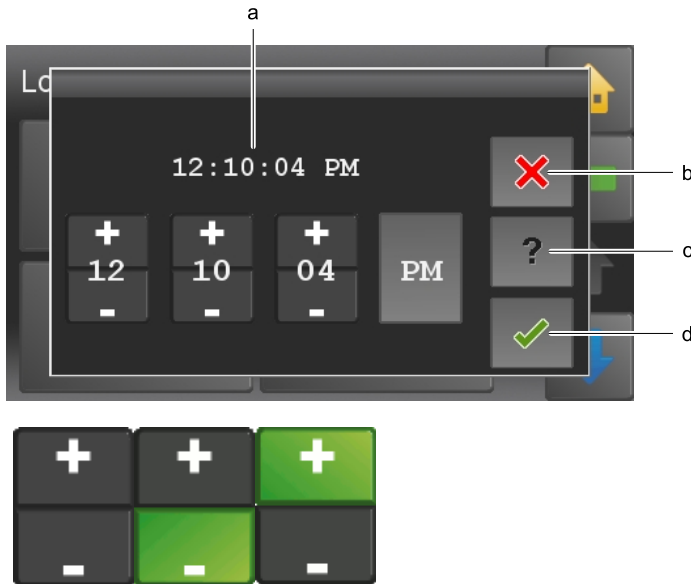

- a. Adjustable time or date
- b. Cancel
- c. Help function - inactive
- d. Confirm

With the Plus Minus block you change numbers.

4. Text selection



- a. Name of parameter
- b. Status texts  
The number of status texts depends of the parameter.

Choose a status text. The setup menu closes automatically and the chosen status text is displayed in the menu.

**Note:**

Although a scroll down menu is open, the navigation icons, menu items and parameters behind are active and by touching them it takes you directly there .

## 9.4 Main Menu

In the Main menu you see all submenus. By finger pressure on an icon you reach the respective submenu.

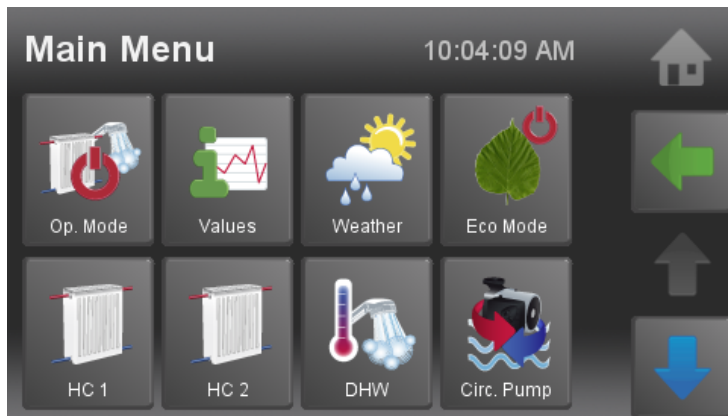

Menu navigation of Pelletronic Touch

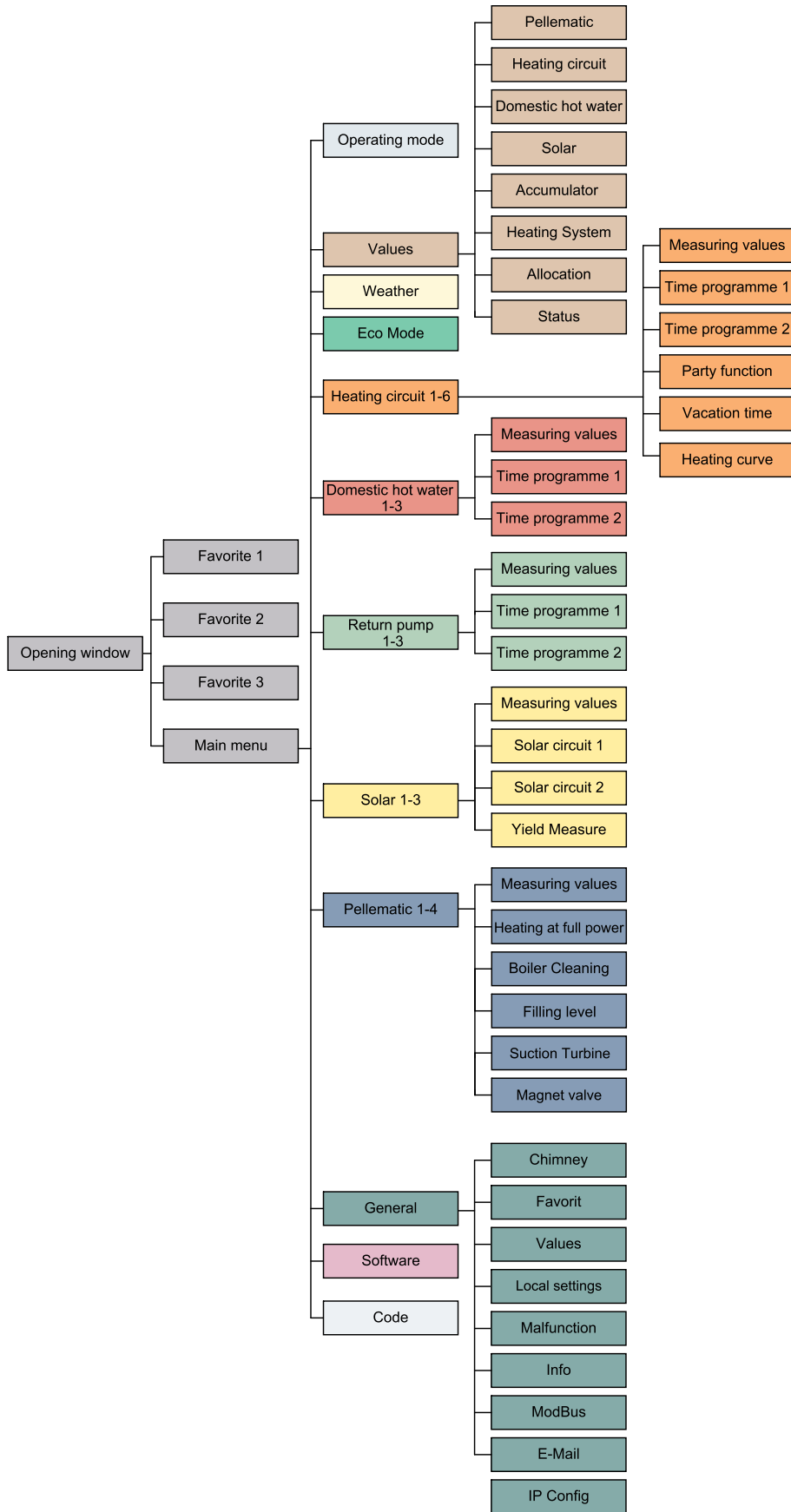

# 10 Mode

In the menu item Mode you can see the mode of your heating system and the mode of the heating circuits, domestic hot water and solar.



The menu item **Mode** is in the Main menu.

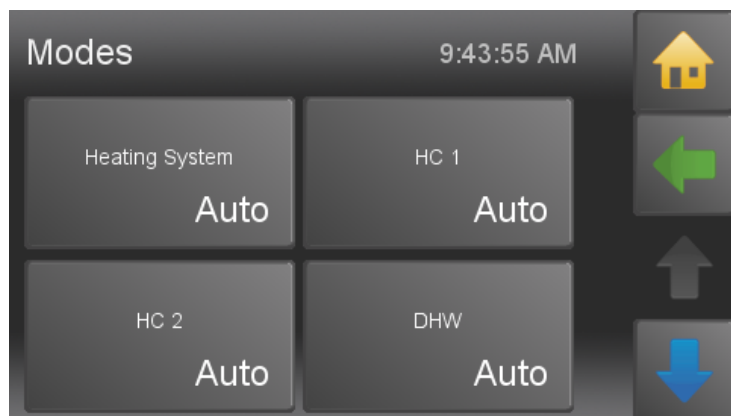

Overview of the operating modes

- Heating Plant
- Heating system 1-6 .
- Domestic hot water 1-3
- Solar 1-3

Choose the operating modes and make settings.

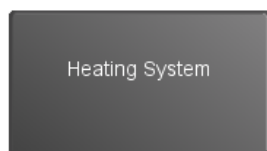

- Off** The adjusted operating mode of the heating circuits and DHW is inactive.  
The frost protection function is active.
- Auto** The adjusted operating mode of the heating circuits and DHW is active.  
The frost protection function is active.
- DHW** The adjusted operating mode of the DHW is active.  
The adjusted operating mode of the heating circuits is active.  
The frost protection function is active.

**The operating mode heating circuits, domestic hot water and solar are described in the respective chapters.**

# 11 Measuring Values

In the menu item of Measuring Values you see all actual and set values of your heating system.



The menu item **Measuring Values** is in the Main menu.



- Pellematic
- Heating circuit
- Domestic hot water
- Solar
- Accumulator
- Return pump
- Heating Plant

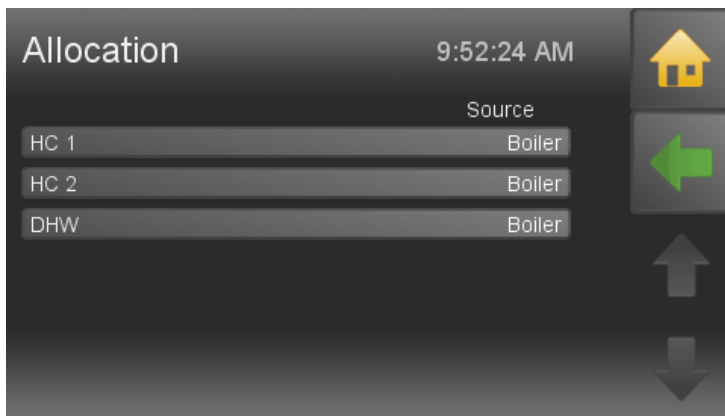

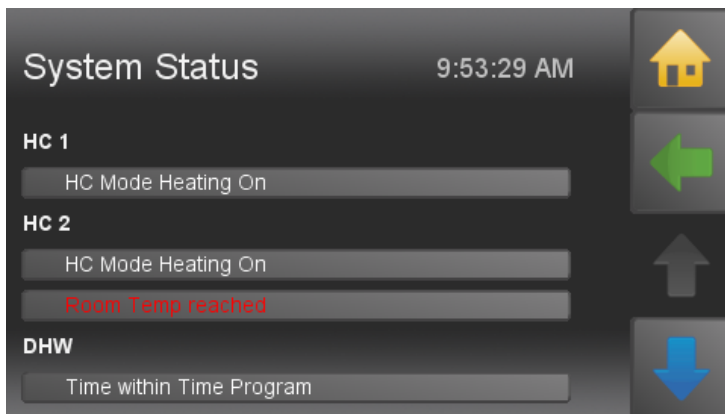

In the menu item **Allocation** you see which heating circuits are allocated to the boiler or to the accumulators.

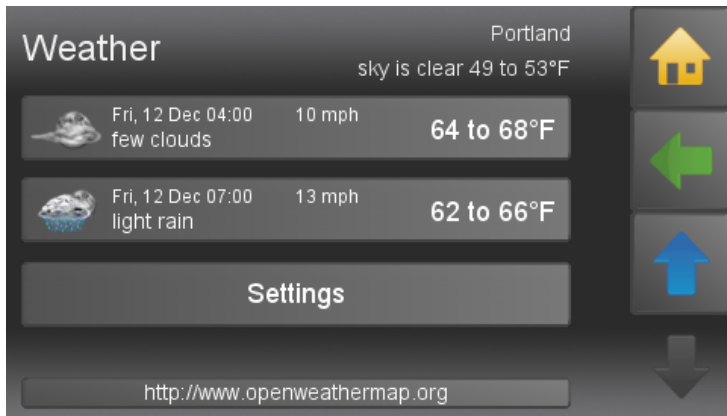

In the menu item **Status** you always have an overview about the whole heating system.

# 12 Weather



Choose **Settings** (  ), to enter your location.



Enter location and country. If the specified location is not found, enter a larger, nearby place.

Search with the following details:

- Postal code, location, country
- Postal code, country
- Location, country



Afterwards, weather data for the next 3 days are downloaded. An icon for the current weather is displayed on the opening window.

**Note:**

This feature requires an internet connection.

# 13 Eco Mode

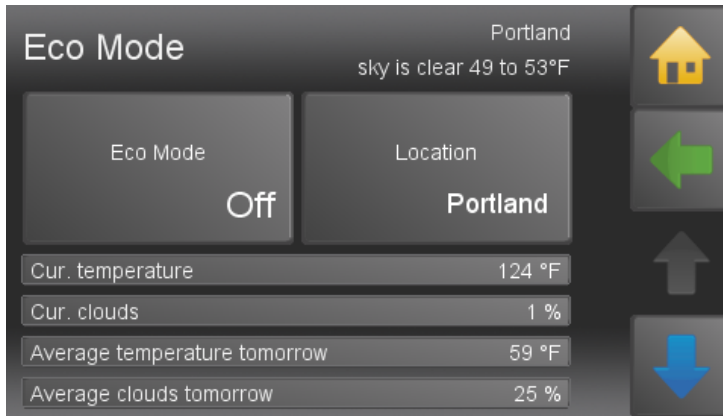

With the Eco Mode, the influence of weather forecasts can be defined.

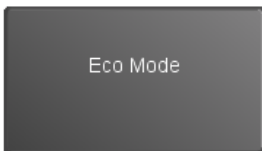

- Off:** Eco mode inactive.
- Comfort:** Set temperature minus 0.9 °F
- Minimum:** Set temperature minus 1.8 °F
- Ecologically:** Set temperature minus 2.7 °F

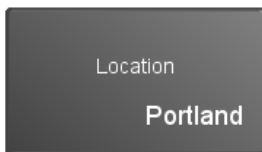

Enter location and country. If the specified location is not found, enter a larger, nearby place.

Search with the following details:

- Postal code, location, country
- Postal code, country
- Location, country

Afterwards, weather data for the next 3 days are downloaded. An icon for the current weather is displayed on the opening window.

**Note:**

This feature requires an internet connection.

**Cur. temperature**

Current temperature according to forecast.

**Cur. clouds**

Current clouds in % according to forecast.

**Average temperature today / tomorrow**

Calculated temperature for the forecast period

**Average clouds today / tomorrow**

Calculated clouds for the forecast period

**Sunrise / sunset**

Time at sunrise or sunset

**Starttime/ Endtime**

In this time frame, the Eco Mode affects the heating settings.

**Last update**

Time of last update of the forecast.



# 14 Heating Circuit

**Heating Circuit** encloses all for heating relevant parameters and settings. It can occur up to 6 menu items **Heating Circuit**.



**Heating Circuit** is in the Main menu

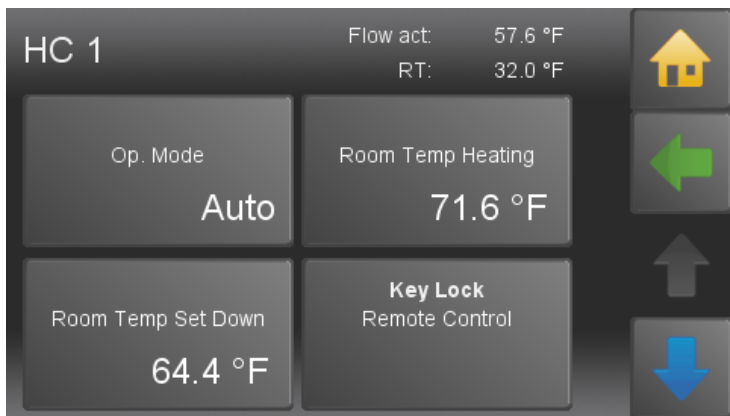

Heating circuits settings has following menu items:

- Mode
- Room Temp Heating
- Room Temp Set back
- Time Allocation
- Values
- Time 1
- Time 2
- Party
- Vacation
- Heatingcurve

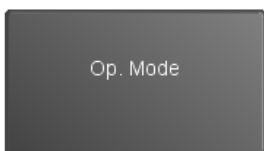

**Off** Only the frost protection function is active.

**Auto** The boiler starts in the heating times according to the Set room temperature.

**Heating** The boiler heats constantly according to the Set room temperature.

**Set back** The boiler heats constantly according to the Set back room temperature.

The operating mode of the heating circuits can only be changed if the plant operating mode is set to AUTO. The adjusted heating limits and maximum flow temperatures are used in all operating modes.

Choose your room temperature (Temperature within the heating times).

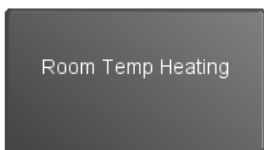

Choose Room Temp Set back (= Minimum temperature beyond the heating times).

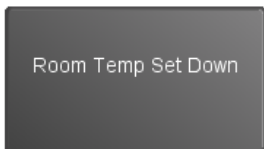

Activate **Time 1** (= Time programme 1) and **Time 2**.

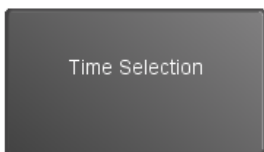

## 14.1 Measuring values Heating circuit



Measuring values HC is in the Main menu.

Values		9:58:36 AM	
HC		Act	Set
Outside Temperature	-0.3 °C		
Boiler Temperature	24.7 °C	8.0 °C	
Burner Contact	Off		
Existing Boiler	60.5 °C		
Switching Valve	On		
HC1 Flow Temperature	14.3 °C	28.9 °C	
HC1 Pump	On		

You see all to the Heating circuit corresponding measuring values:

- Actual value
- Set value
- Inputs (sensors)
- Outputs (pumps, mixer and motors)

<b>Outside Temperature</b>	actual Outside Temperature
<b>Boiler Temp</b>	actual Boiler Temperature
<b>Existing Boiler</b>	actual Temperature of available boilers
<b>ACC1 TPO</b>	actual temperature AC upper sensor
<b>ACC1 TPM</b>	actual temperature AC middle sensor
<b>ACC1 Pump</b>	actual performance of Accumulator pump
<b>Booster</b>	Status (Booster On/Off)
<b>Flow Temp</b>	display of the flow temperature
<b>Room Temp</b>	display of the room temperature
<b>Pump</b>	Status (Pump On/Off)
<b>Mixer</b>	Status (Mixer On/Off)

# 14.2 Time programme Heating circuit

In the heating circuit time programme you fix the heating times.



**Time 1 (=Time programme 1)** and **Time 2** are in the menu Heating circuit.

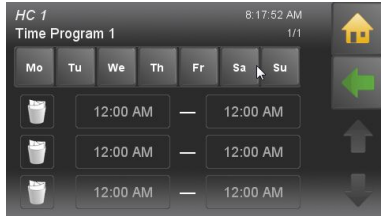

**1** Select Time programme 1

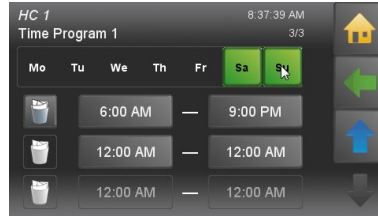

**6** Mo-Fr were assigned heating times

With you get to the remaining days Sa-Su.

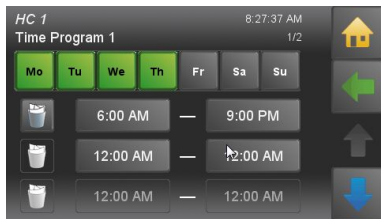

**2** Select the heating days. The activated days are deposited in green.

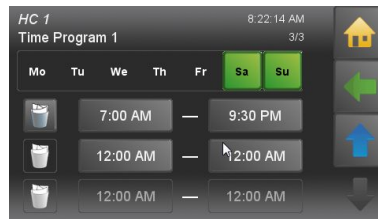

**7** Sa-Su were assigned to heating times.



**3** Enter the heating times for these heating days (Mo-Th).

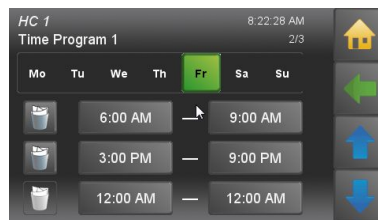

**8** With and you switch between the heating blocks. You can deactivate heating days in the heating block and activate in another.

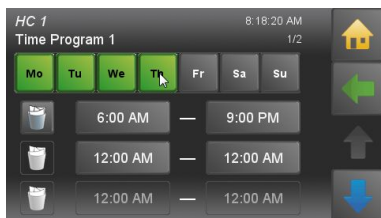

**4** The heating times for Mo-Th are assigned. With you assign to days heating times further.

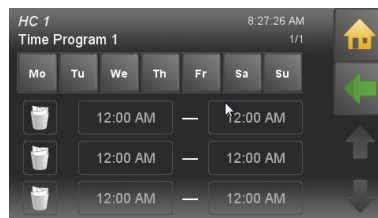

**9** With you set all the heating times in the line and below to 0.

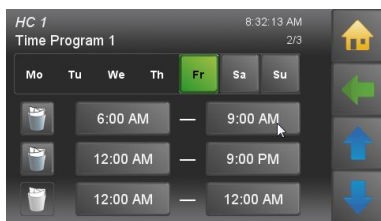

**5** Friday was activated. Heating times were assigned.



**10** Go back with . Choose Time 2. For every heating circuit there are 2 time programmes. You can programm 2 time programmes. In the menu item **Time Allocation** you can activate time 1 or time 2.

## 14.3 Party

The party function extends the heating time once, without changing the heating times.



**Party** is in the Main menu.

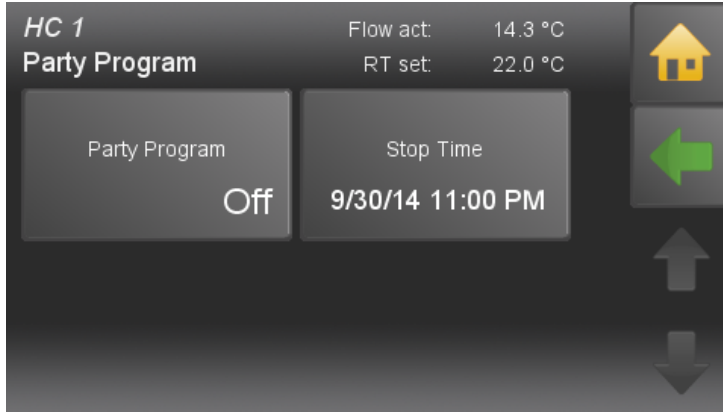

The party function is basically inactive. Enter the time until the room temperature heating should be heated. Activate the Party function. The heating time is extended up to the indicated time. Then the party function deactivates itself automatically.

## 14.4 Vacation

The holiday programme cancels the heating times and heats for the entered period on the set temperature level.



**Vacation** is in the Main menu.

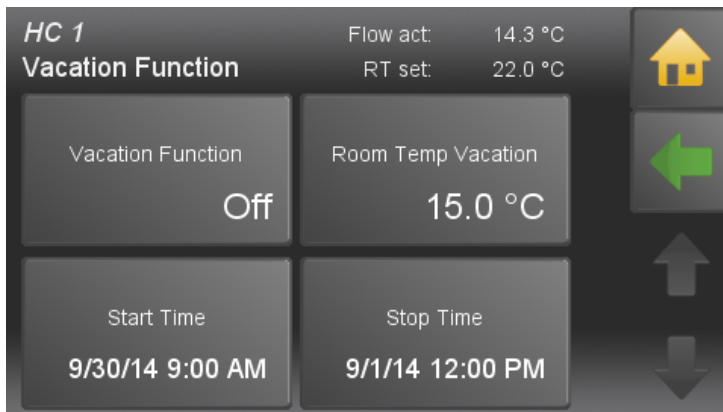

Enter the room temperature on which in your absence the building should be heated. Enter the departure (start time) and return (finish date) and activate the vacation programme.

**Note:**

To return in an already tempered building, you must enter the day before the return as the finish date.

## 14.5 Heating curve and Heating limits

By starting up the first time, the authorised technical adviser adjusts the heating curve, the base point and the heating limits on the building situation and the hydraulics. If the Set room temperature is not reached or exceeded, adjust the heat curve with the flow temperatures according to outside temperatures.



Heating curve is in the menu **Heating circuit**.

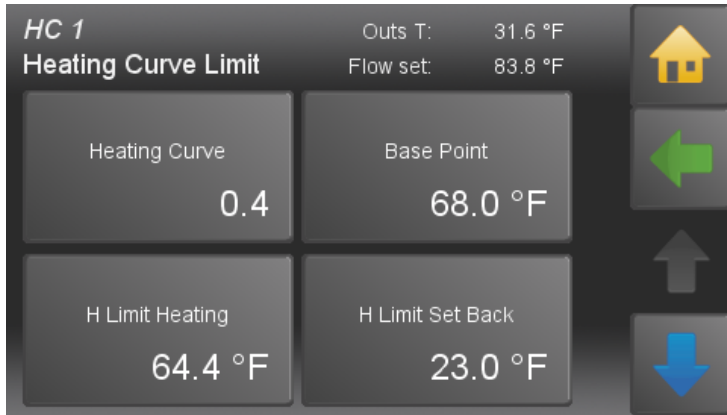

### Heating curve 0.0 - 4,0

The heating curve describes the combination between outdoor temperature and the associated flow temperature for a heating circuit.

### Base point adjustable from 68 - 113°F

With the change the of base point, you provide a parallel shift of the heating curve.

### H limit heating

If the average outside temperature is higher than the set temperature, the heating circuit switches off in the heating mode.

### H limit set temperature

If the average outside temperature is higher than the set temperature, the heating circuit switches off in the Set back mode.

### Adjustment of heating curve and the base point to the building

Because of the building's thermal inertia, it is recommended to perform no more than one adjustment step per day.

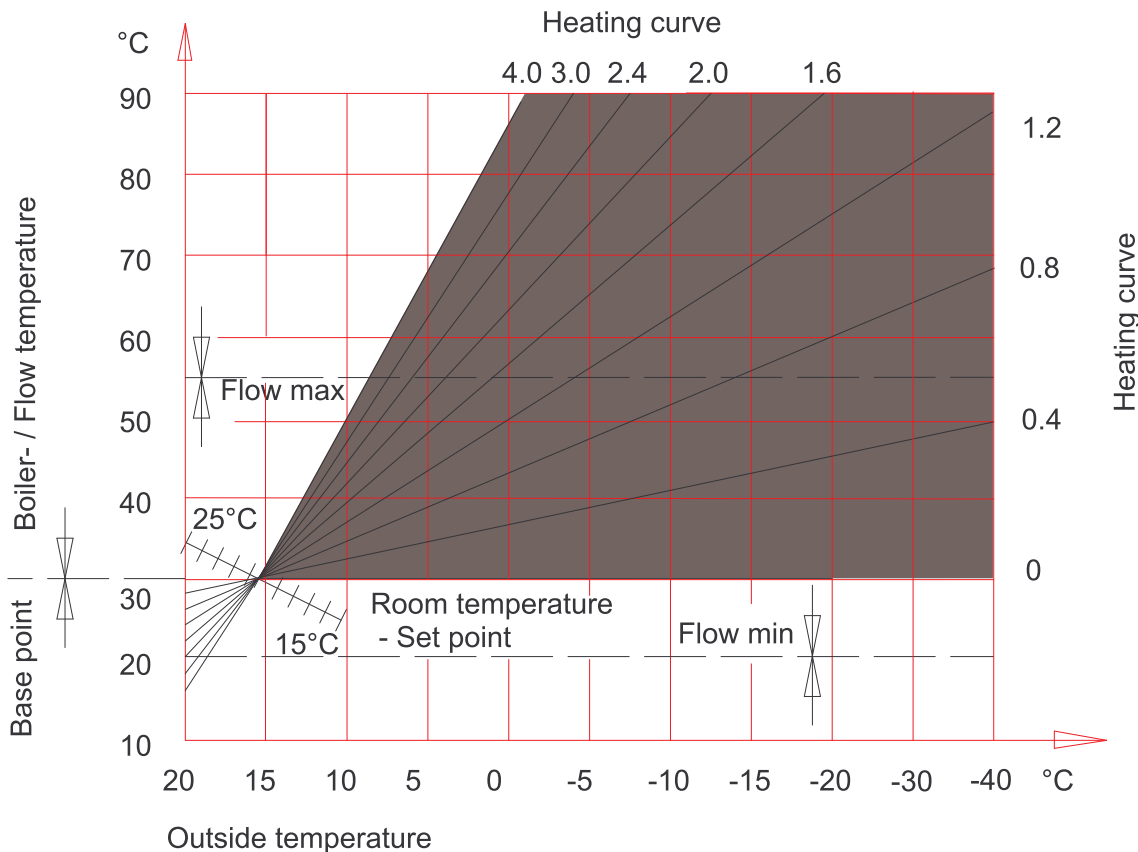

Daytime outside temp	Room temperature	
	too warm	too cold
+5 to +15°C	Decrease heating curving value by 0,2	Increase heating curving value by 0.2
	Decrease base point value by 5°	Increase base point value by 5°
-20 to +5°C	Decrease heating curve value by 0.2	Increase heating curve value by 0.2

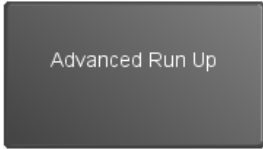

The advanced run up indicates how long the system has to heat before the start of the heating time, to reach the adjusted **roomtemp heating**.

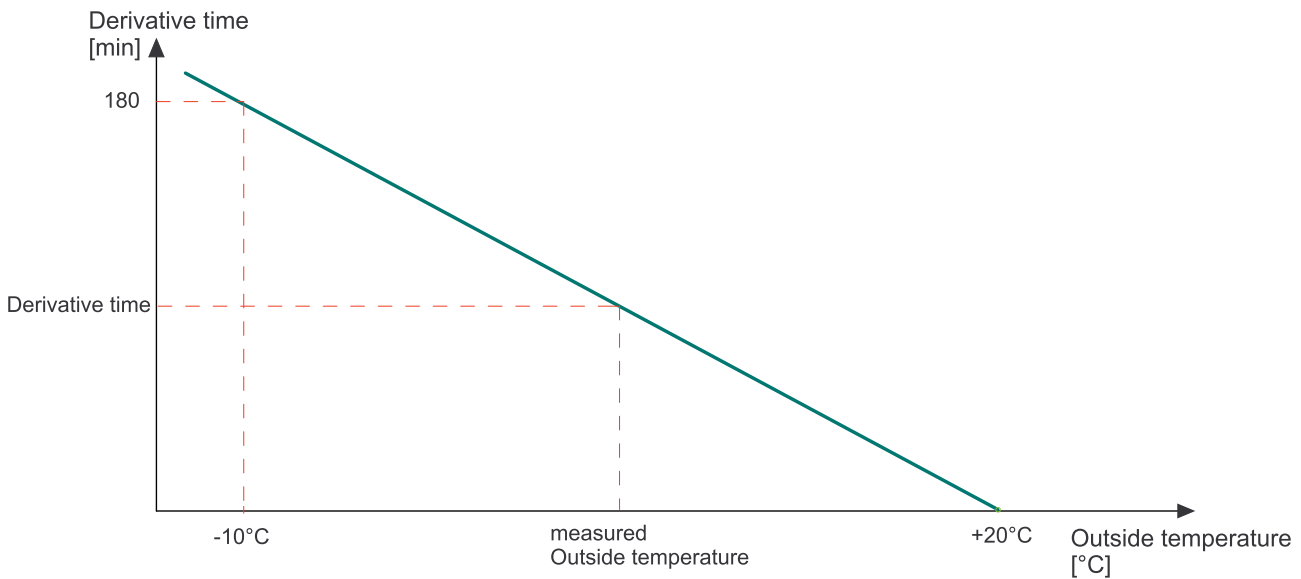

**Room thermostat influence**

If the measured room temperature deviates from the set room temperature, the heating controller corrects the flow temperature with the Room thermostat influence. The Room thermostat influence indicates how much the flow temperature is raised or lowered so that the Set room temperature is reached.

**Example:**

Room temperature desired value = 20°C

Room temperature actual value = 18°C

} Temperature difference 2°C

Room sensor influence = 3

<b>Room sensor influence</b>	*	<b>Temperature difference</b>	=	<b>Advanced run up rise/reduction</b>
<b>3</b>	*	<b>2</b>	=	<b>6°C</b>

### Room temperature hysteresis

The Room temperature hysteresis prevents the cycling (On Off On Off...) of the heating circuit pump: If the Set room temperature + room temperature hysteresis is reached, the associated pump stops. If the Set room temperature is - 1°C, the pump switches on again.

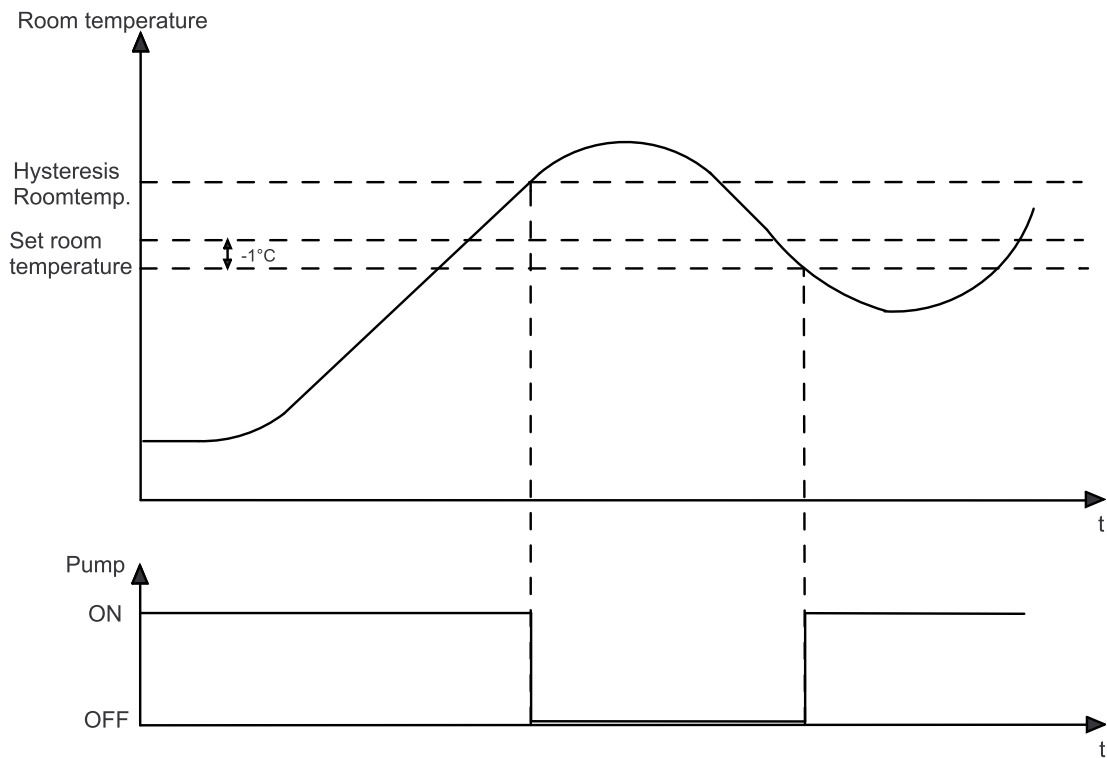

# 15 Domestic hot water

The menu Item **Domestic hot water** contains up to 3 submenu items. Domestic hot water includes all, for the preparation of hot water, relevant parameters and settings.



**Domestic hot water** is in the main menu.

DHW settings has following menu items:

- Mode
- DHW Boost
- Water Temp Set
- Water Temp Min
- Time programme
- Values
- Time 1
- Time 2

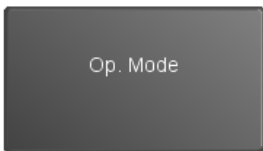
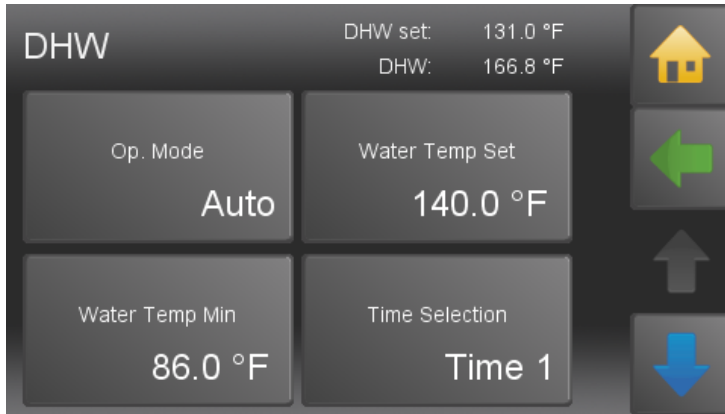

**OFF** Set water temperature is reduced to 46 °F for frost protection.

**Auto** The installation heats the water within the time programme to the **desired hot water temperature**. Outside the time programme the installation heats to **Watertemp min**

**On** The system heats up the domestic hot water continuously on the Water temp set.

You can change the mode domestic hot water only when the **Operation mode** is on **AUTO**.

Heats the hot water once on the Water temp set.

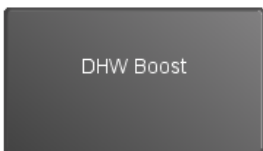

Set the water temperature.

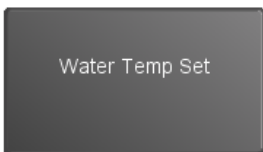

Set the minimum water temperature. The water temperature never falls below this value, unless the domestic hot water mode is on **OFF**.

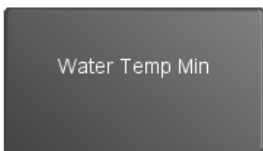

Activate **Time 1** (= Time programme 1) and **Time 2**.

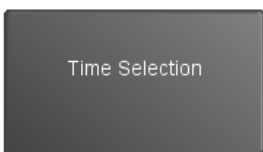





You are able to see a list of all measuring values that are involved in the menu domestic hot water.



In the DHW time programme you set the times of the hot-water processing. The DHW time programme works the same way like the heating circuit time programme. See chapter [14.2 Time programme Heating circuit, page 38](#)

## 15.1 Measuring values Domestic hot water



**Measuring values DHW** is in the Main menu.

Values		8:53:20 AM	
DHW			
	Act	Set	
Outside Temperature	-0.3 °C		
Boiler Temperature	23.6 °C	8.0 °C	
Burner Contact	Off		
Existing Boiler	60.4 °C		
Switching Valve	On		
DHW1 Temperature	75.1 °C	55.0 °C	
DHW1 Pump	Off		

You see all the Heating circuit corresponding measuring values:

- Actual value
- Set value
- Inputs (sensors)
- Outputs (pumps, mixer and motors)

## 15.2 Time programme DHW

In the DHW time programme you set the times for the hot-water processing.



**Time 1 (=Time programme 1)** and **Time 2** are in the menu **Domestic hot water**.

DHW		8:50:56 AM					
Time Program 1							
	Mo	Tu	We	Th	Fr	Sa	Su
	6:00 AM	—	9:00 PM				
	12:00 AM	—	12:00 AM				
	12:00 AM	—	12:00 AM				

The domestic hot water time programme works the same way like the heating circuit time programme.

See chapter [14.2 Time programme Heating circuit, page 38](#)

# 16 DHW Return pump



**DHW Return pump** is in the Main Menu.

The Return pump enables the immediate DHW tap of the water taps. DHW Return pump has following menu items:

- Mode
- Switch off temperature
- Switch on hysteresis
- Time allocation
- Values
- Time 1
- Time 2

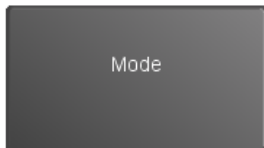
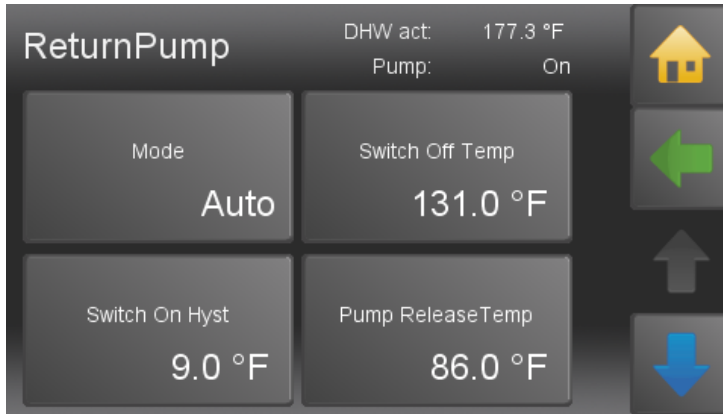

**Off** DHW Return pump inactive

**Auto** Temperature regulation within the time programme

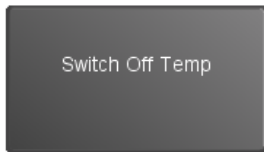

If the return temperature sensor of the DHW Return pump reaches the **Switch off temperature**, the pump switches off.

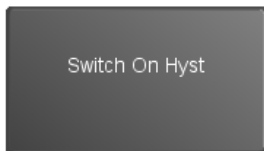

If the return temperature falls below the switch off temperature - the DHW Return pump switches on again!

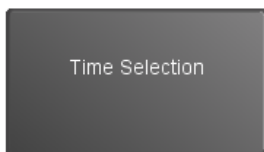

Choose the time programme 1 or 2.



You see all the DHW pump corresponding measuring values.



Set the run times of the Return pump. The return pump - time programme works the same way like the heating circuit time programme. See chapter [14.2 Time programme Heating circuit, page 38](#)

**Note:**

A **Return Pump** and a **booster** rule out each other.

## 16.1 Measuring values DHW Return pump



Measuring values DHW Return pump is in menu DHW Return pump.

Values		12:13:54 PM	
ReturnPump		Act	Set
Outside Temperature	-0.2 °C		
Boiler Temperature	24.1 °C	8.0 °C	
Burner Contact	Off		
Existing Boiler	60.5 °C		
Switching Valve	On		
DHW1 Temperature	75.1 °C	55.0 °C	
DHW1 Pump	Off		

You see all the Heating circuit corresponding measuring values:

- Actual value
- Set value
- Inputs (sensors)
- Outputs (pumps, mixer und motors)

## 16.2 Time programme DHW return pump

In the Time Programme DHW Return Pump you set the times for the hot water in the water purchasers.



Time 1 (=Time programme 1) and Time 2 are in the menu DHW return pump.

ReturnPump		11:36:05 AM	
Time Program 1		1/1	
Mo	Tu	We	Th
Fr	Sa	Su	
	6:00 AM	—	9:00 PM
	12:00 AM	—	12:00 AM
	12:00 AM	—	12:00 AM

The DHW return pump time programme works the same way like the heating circuit time programme.

See chapter [14.2 Time programme Heating circuit, page 38](#)

# 17 Solar

Solar includes all relevant parameters and settings for the solar thermal system. You can control up to 6 solar circuits.



**Solar** is in the Main menu.

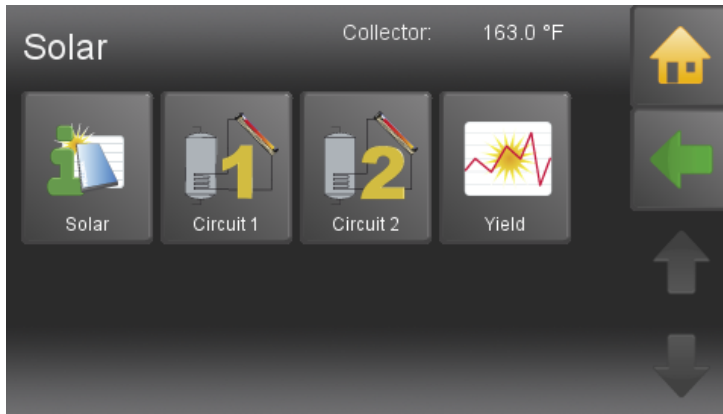

Solar has following menu items:

- Measuring values Solar
- Solar circuit 1-2
- Solar energy- yield

## 17.1 Measuring values Solar



**Measuring values Solar** is in the menu Solar.

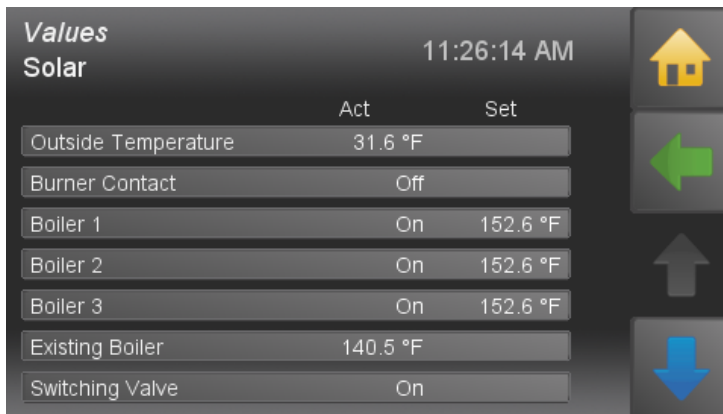

It displays all measuring values of Solar:

- Actual values
- Set values
- Inputs (sensors)
- Outputs (pumps, mixer and motors)

## 17.2 Solar circuit



**Solar circuit 1 and 2** are in menu Solar.

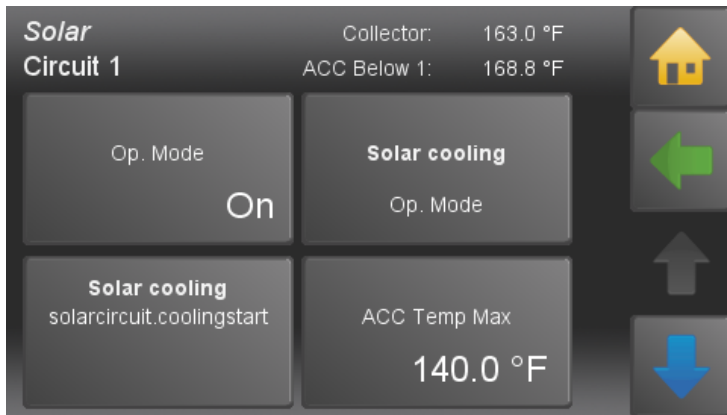

**Solar circuit** has following menu items:

- Operation Mode
- ACC Temp Max
- ACC Hysteresis
- Collector Hyst On
- Collector Hyst Off

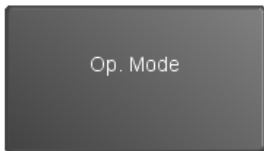

**Off:** No charge

**On:** Charge as long as **Collector temperature + hysteresis** is lower than the temperature of the **Adj ACC sensor below** or the **ACC temp max**

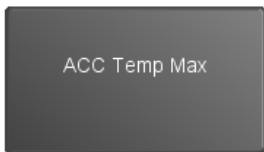

If the temperature in the ACC is higher than the ACC temp Max, the solar pump switches off. The limit sensor measures the temperature in the ACC.

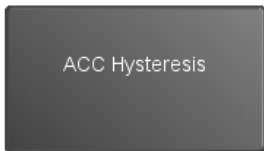

The solar circuit pump is switched off due to the ACC temp Max is reached. The temperature must fall under ACC temp Max minus hysteresis, then the solar circuit pump switches on again. The hysteresis prevents a solar pump cycling (On Off On Off).

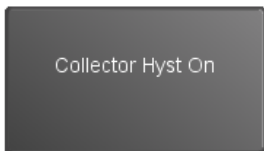

If the temperature difference between the collector sensor and TPU, ACC lower sensor is higher than the Coll Hyst A, the solar pump switches On.

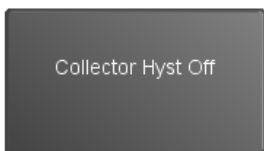

If the temperature difference between the collector sensor and TPU, ACC lower sensor is lower than the Coll Hyst A, the solar pump switches Off.

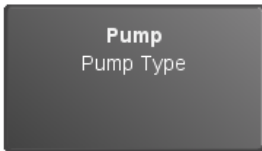

The menu **Pumptype** contains the following modes:

**Asynchronous:** Asynchronous pump – direct output 230VAC on/off

**Async.Regulated:** Asynchronous pump – pulsed output 230VAC

**Heating Efficient:** PWM1 - PWM signal inverted

**Solar Efficient:** PWM2 - PWM direct signal

**Note:**

When using a A-class pump as **Accumulator pump** the pump cannot be regulated from Solar circuit 2.

## NOTICE

Material damage by false selection of pump!

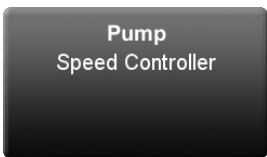

**Off:** Speed controller Off

**On:** Speed controller On

## NOTICE

Material damage by false configuration of pump type and speed controller!

## 17.3 Yield - Solar Energy

This function measures the yield of the solar thermal system and displays current energy and logs previous days.

For the function solar energy it is necessary to install:

- Pulse volume meter (must be connected to **24 VOLT** and **Z\_IN**)
- Flow temperature sensor
- Return temperature sensor



**Yield - Solar Energy** is in the menu Solar.

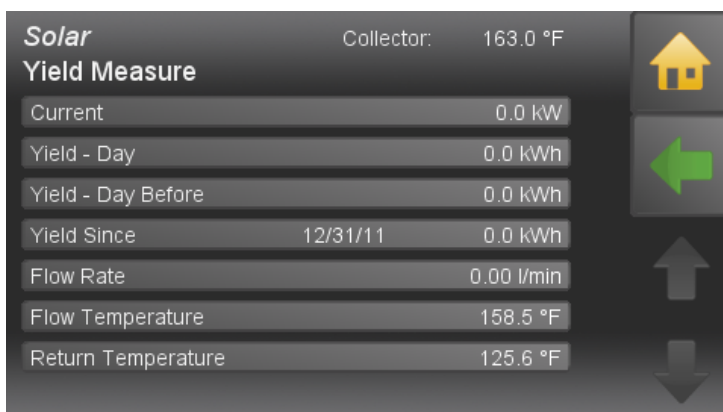

Yield measuring of solar energy has following menu items:

- Actual  
Display of the current solar energy, refreshes every 60 sec.
- Yield - Day  
Display of todays solar energy since 00:00.
- Yield - Day before  
Display of yesterdays solar energy.
- Yield since  
Display of the solar energy since the last set date.
- Flow rate  
Display of the current flow rate, refreshes every 60 sec.
- Flow temperature  
Display of the current flow temperature
- Return temperature  
Display of the current return temperature

# 18 Pellematic

Pellematic includes all the relevant parameters and settings for the control of the pellet boiler. There are up to 4 Pellematic boilers possible.



**Pellematic** is in the Main menu.

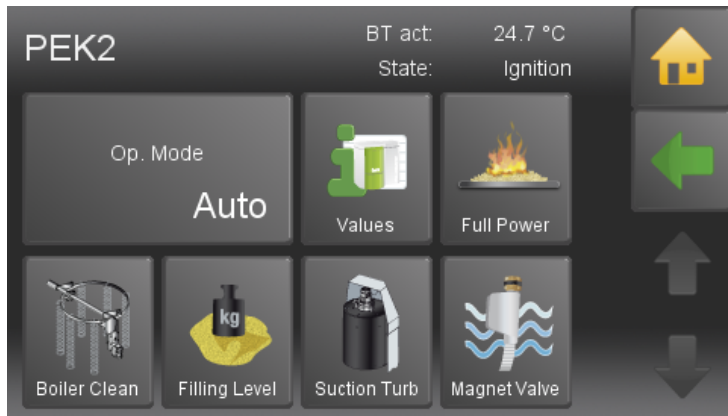

Pellematic has following items:

- Measuring values Pellematic
- Permanent operation
- Full power
- Burner plate cleaning
- Boiler cleaning
- Pellet level
- Suction turbine

## 18.1 Measuring values



**Measuring values** is in the menu Pellematic.

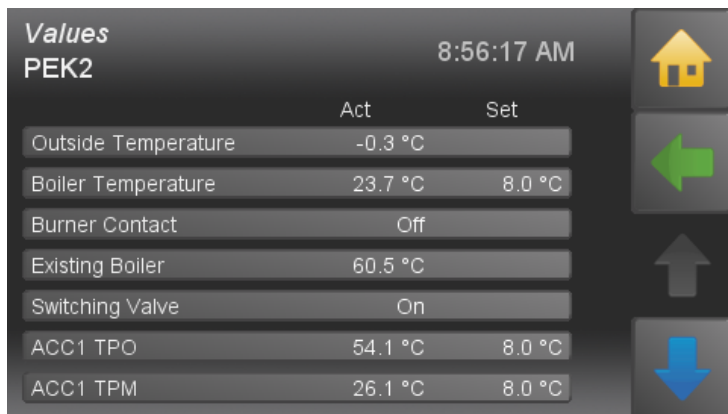

It displays all measuring values of Pellematic:

- Actual values
- Set values
- Inputs (sensors)
- Outputs (pumps, mixer and motors)

See chapter [14.1 Measuring values Heating circuit, page 37](#)

## 18.2 Full Power



**Full Power** is in the menu Pellematic

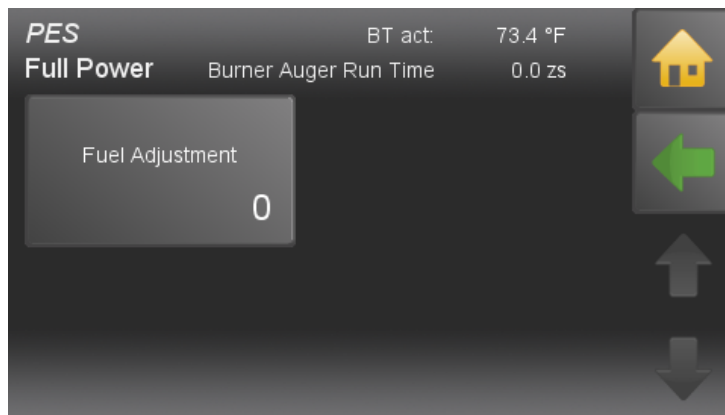

In the menu item Full Power can you adjust the fuel feed.

### **Fuel Adjustment:**

The burner auger run time is calculated automatically by the PLC depending on the rated power and the boiler setpoint temperature. The burner motor is controlled accordingly. You can reduce or increase the value calculated by the PLC 10 steps up or down.



## 18.3 Boiler cleaning

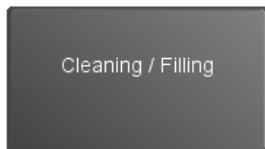
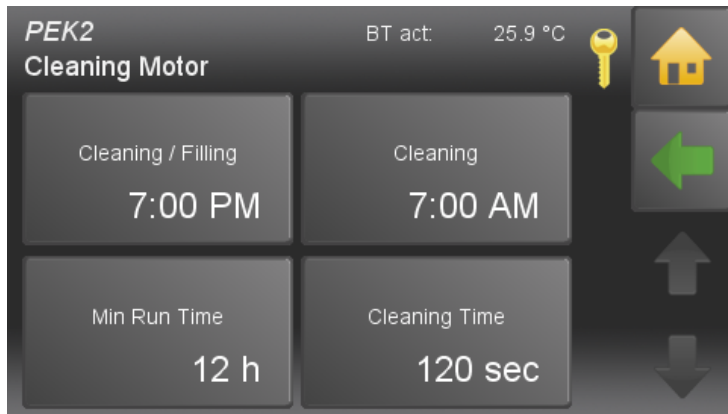

The value to be set is the time (full hour) at which the boiler cleaning sequence is performed. On vacuum systems the hopper is also filled at the same time, regardless of whether it is empty or not.

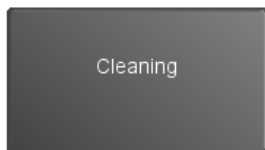

You can set in **Cleaning/Filling** a second cleaning sequence. The value to be set is the time (full hour) at which the additional boiler cleaning sequence is performed. Example: 20h = additional boiler cleaning sequence performed at 20:00. On vacuum systems the hopper is also filled at the same time, regardless of whether it is empty or not.  
Default value -1h: It is not performed a second cleaning sequence.

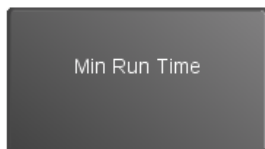

Min Run Time of the boiler until next cleaning sequence. Value adjustable.

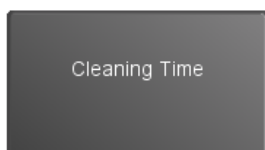

Duration of the boiler cleaning sequence in seconds. Value adjustable.

## 18.4 Level detection system

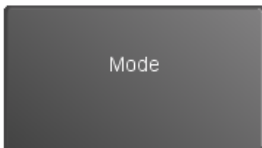
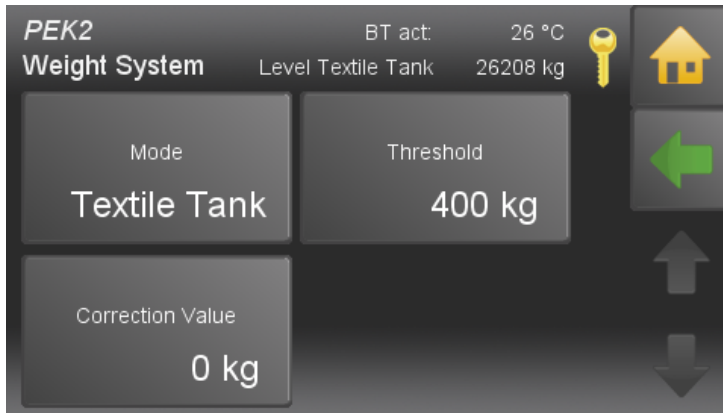

Selection options:

- Off**                      Function level detection system inactive.
- Textile tank**        Level detection system of textile tank by weighting cells.
- Storage room**        Put in the filling quantity after a pellet delivery. Level detection by weighting system of hopper. Only possible with Pelletboilers of the type PES 36-56.
- Cap sensor**        Filling level detection in textile tank or storage room by capacitive sensor.

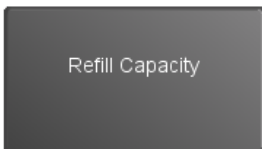

Insert filling amount after filling the storage room.

**Note:**

Displayed only if mode is set on **Storage room**.

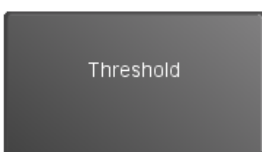

The threshold value, **Minimum weight** for a warning message, is adjustable. The warning message appears on the operating device and will be terminated when filling level rises above the adjusted Minimum weight.

**Note:**

Only displayed if mode is set on **Storage room** or **Textile tank**

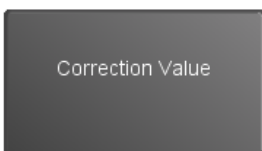

Set the display of the current weight to 0 by putting in the negative of the current weight shown.

**Note:**

Displayed only if mode is set on **Storage room** or **Textile tank**.

## 18.5 Suction turbine



### Note:

The menu item **Suction turbine** is only visible in suction systems.

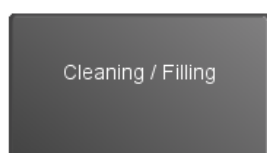
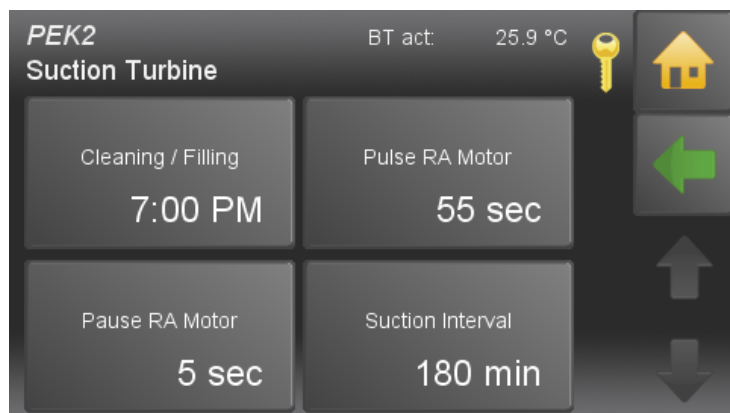

Set a Time (full hours), at which the hopper gets refilled, regardless how full it is at this time.

At the same time the purification of the boiler will take place. This adjustment matches Cleaning/Filling.

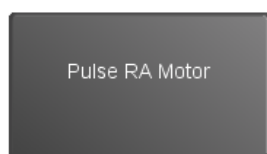

Frequency for storage room suction systems in pulse mode, only for vacuum systems.

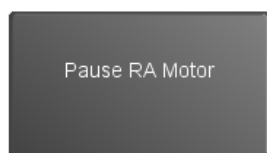

Pause time for storage room extractor motor - suction system in pulse mode. If pause time = 0 then no pulse mode.

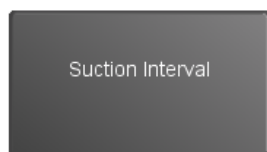

Run time of burner auger until next Suction Interval.

The hopper is filled at this time regardless whether it is empty or not.

- 175 min = 12 - 20 kW
- 225 min = 25 - 32 kW
- 90 min = 36 - 56 kW

# 19 General

General includes the complete heating control related settings and individual operating options for the customer.



**General** is in the Main menu.

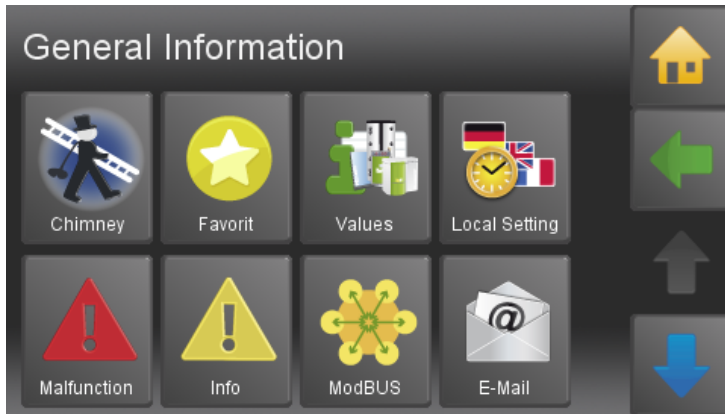

The menu **General** includes::

- Chimney
- Favorit
- Local setting
- Malfunction
- Info

## 19.1 Chimney

The function chimney is only for chimney droughts and authorized service technicians. It is used for the measurement of exhaust gas.



The menu item **Chimney** is situated in the menu General.

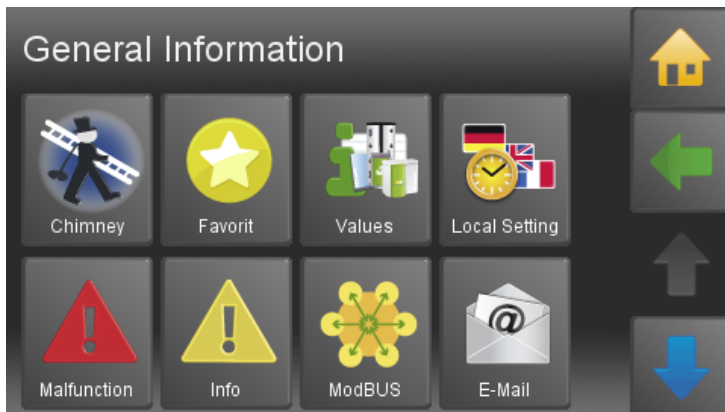

Please choose the function **Chimney**.

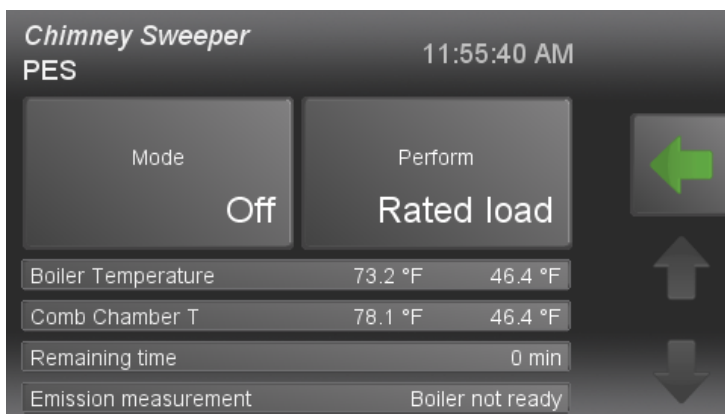

- The boiler temperature is set to 140 °F for a total runtime of 30 minutes.
- You also can see actual boiler temperature and the rest of the time limit.
- After the expiry of the time limit the function chimney ends.time of expiry the operation Chimney sweeper ends.
- The button Cancel ends the function Chimney.

## 19.2 Favorite



**Favorite** is in the menu General.



With this function you can display most commonly used menus in the start menu. This enables you a direct access.

Select the menu item that should be displayed as a favorite 1 in the Start menu.

The selected item is green and the icon is displayed in the Start menu and is active.

## 19.3 Local Settings



**Local Settings** is in the menu General.

Local Settings has following menu items:

- Language
- Unit
- Date
- Time

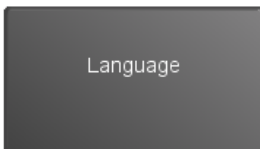

Choose between the languages German, English UK, English U.S. French, Spanish, Italian, Dutch, Danish and Russian.

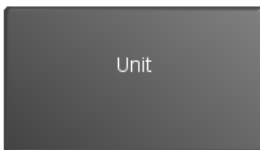

You can choose between isometric and imperialist number system.

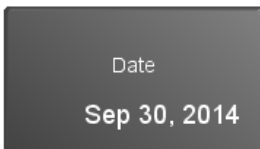

Set the current date.

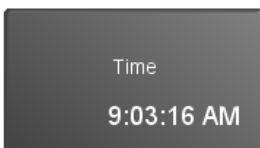

Set the current time.

## 19.4 Malfunction



**Malfunction** is in the menu General.

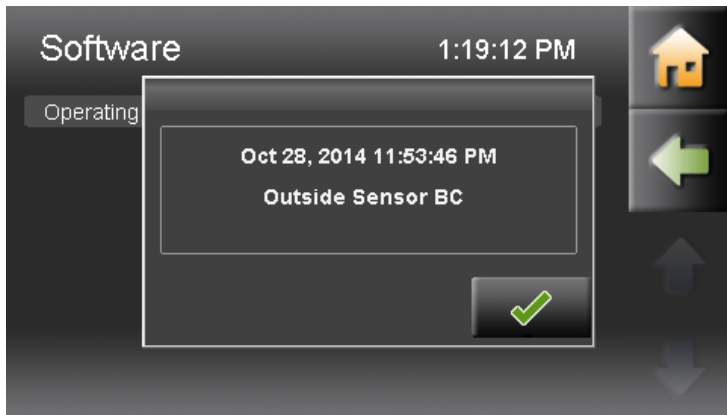

Fault messages can be overlaid on all menu items and appear immediately if a fault occurs. Every fault message appears with the date, time and name on the display. It remains until it is acknowledged.

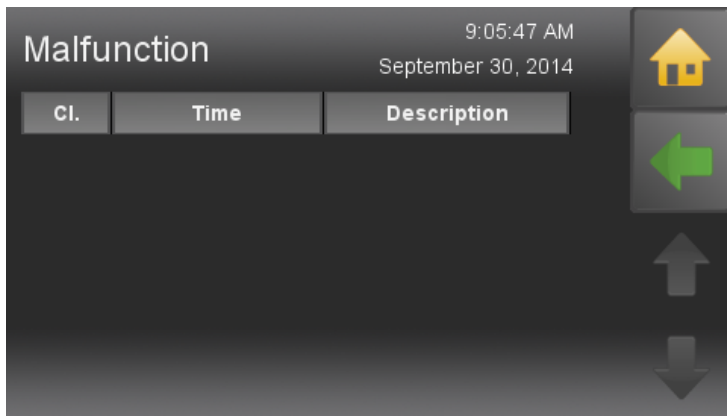

The menu remains the fault incident reports, as long as they are corrected up.

## 19.5 Information



**Information** is in the menu General.



In the menu item information are all faults listed chronologically.

The fault texts have 3 status

- C.....COME — when the fault occurs
- Q.....QUIT — when the fault has been rectified
- G.....GONE — when the fault has been reset by pressing ENTER

## 19.6 ModBUS

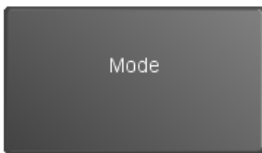
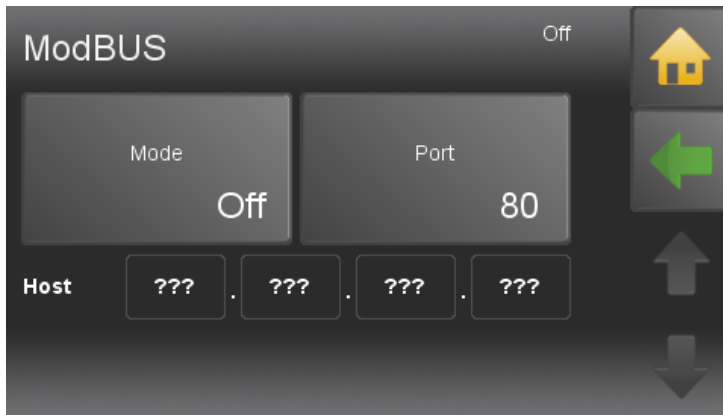

**Off**  
**TCP Server**

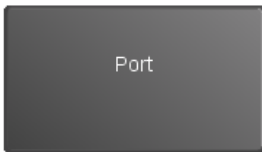

Defaultport for ModBUS is 502.



## 19.7 E-Mail

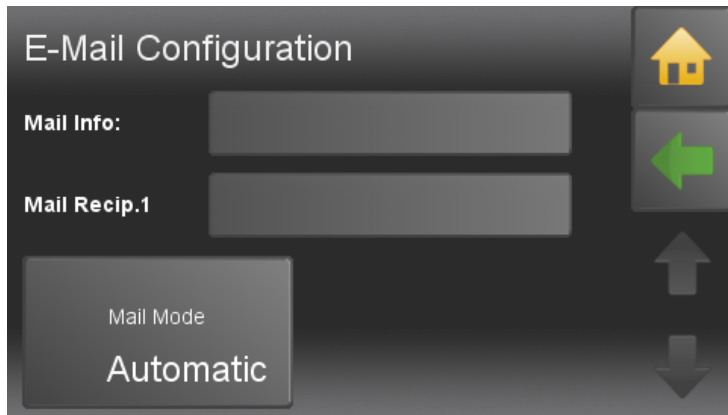

Delivery of disturbance-emails is done through an Maine Energy Systems server.

Only the recipient address needs to be configured.

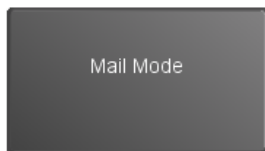

Mail Mode

To ensure maximal flexibility, E-mail settings can set individually.

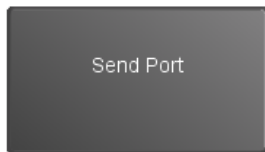

Send Port



Security

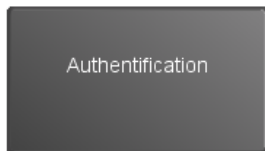

Authentication

## 19.8 IP Config

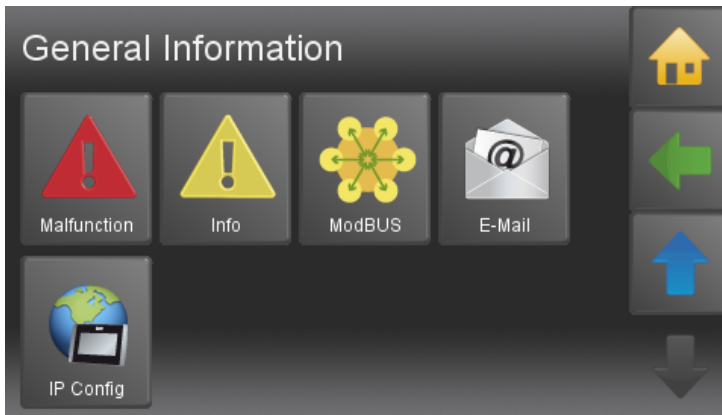

Please choose the submenu item **IP Config** in the menu General.

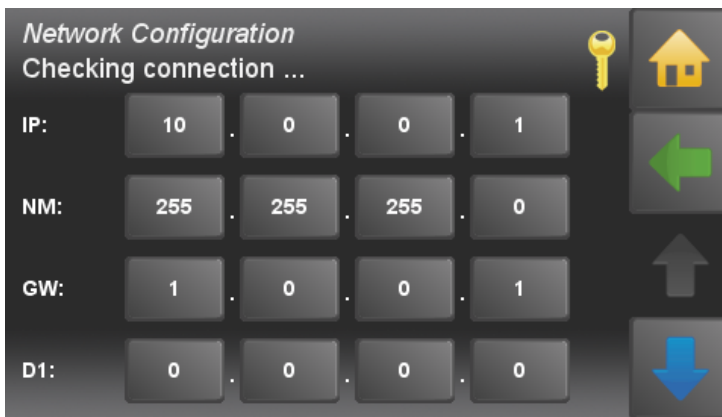

Insert the **IP (Address)**, **NM (Netmask)** and **GW (Gateway)**, D1 (in most cases similar to GW) and **D2 (optional)**.

**IP:** IP address in the local network

**NM:** Networkmask is required in the local network.

**GW:** The gateway enables the touch operating device the access to the internet.

**D1, D2:** Server, which provide routing information

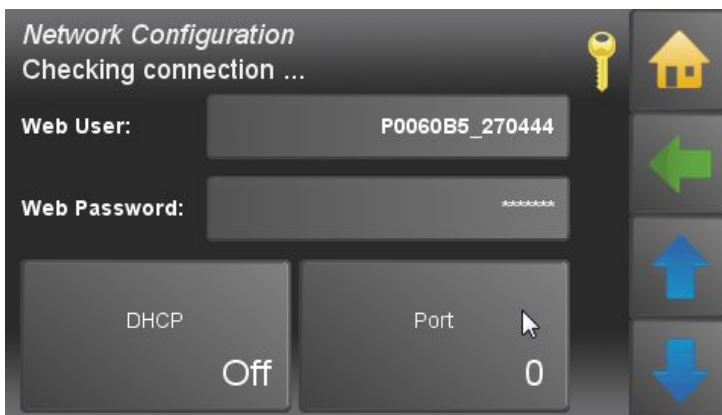

Set **DHCP On** or **Off** depending on your network.

Enter the **Port** (Default **80**).

**Web:** IP address in local network

**Web User:** Networkmask is required in local network

**Web Password:** The gateway enables the touch operating device the access to the internet.

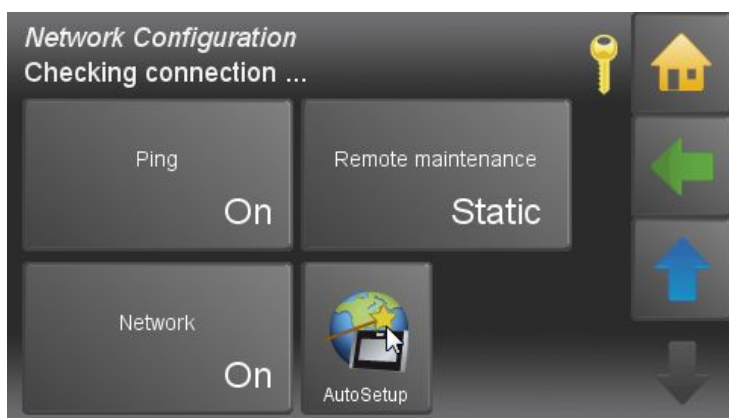

Activate optionally the **Ping** function.

## NOTICE

To prevent the modem from switching into standby mode, a ping command is executed every 10 minutes.

**You get the data from your network technician.**

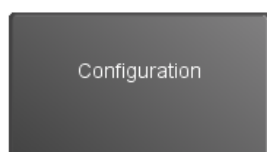

This menu item is only active when a compatible USB wireless adapter is connected. (not every wireless stick works with the Touch operating device)  
By default, this item is hidden and located in LAN mode.  
If the wireless mode is enabled, a password box appears.

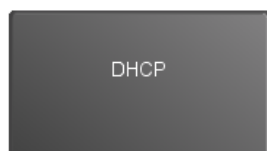

Dynamic address assignment on the local network (should be disabled if possible).

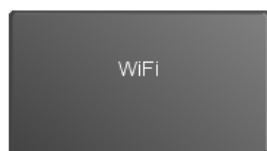

If a WLAN stick is recognized and supported, an Additional LAN & WLAN button appears.

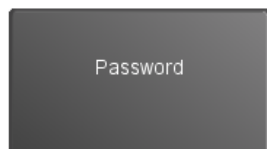

Password of router.

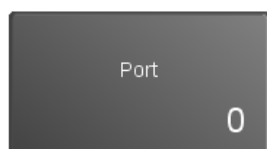

Address extension with which the touch remote control is accessible.  
In principle, you can make your own choice, certain ports are associated with special services, e.g. 25 Mail, 80 Web and so on.

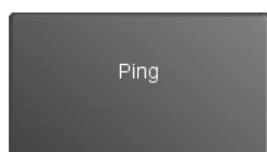

The ping prevents the internet connection from being closed by the router.  
Therefore a query to the Maine Energy Systems server is started at certain time intervals.  
So the router detects that the connection is still active.

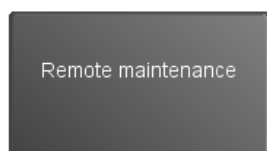

**Automatic:** This will attempt to automatically set up the router using the UPNP protocol port forwarding.  
If this service is disabled on the router or doesn't work properly, it is canceled accompanied by an appropriate error message.  
As this function is time-consuming (may take a few minutes), it is running in the background. Whatever the UPNP  
If available, the Touch operating device registers on the Maine Energy Systems remote control server with its current external IP Address.  
In case of change of address by the external provider, this is detected and sent to the server Maine Energy Systems.

**Manual:** In this mode, the port forwarding must be set manually. (for lack of UPNP)

The port of the touch panel must correspond to the external shared port.  
The touch then registers with the external IP address and port on Ök-oFEN remote maintenance server.  
In case of change of address by the external provider, this is detected and sent to the Maine Energy Systems server.

**Static:** In this mode, no connection data is transferred to the Maine Energy Systems server and the online service of Maine Energy Systems can not be used.  
But the remote controll of the Touch operating device remains active and can be uses as before via port forwarding, DynDns, fixed external IP, LAN and so on.



Back to the menu **General**.

### Remote maintenance access



This function determines the network settings automatically.  
For this the DHCP mode is activated and the required settings are set automatically.  
Afterwards DHCP is deactivated.  
Because of this, the IP address of the contol unit can change.

The settings are set as follows:

- DHCP Off
- Ping On
- Port 8080
- Remote maintenance: Automatic

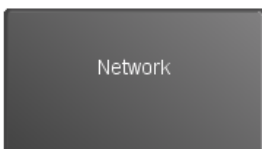

All functions for the network/internet can be disabled here.

## 20 Software



**Software** is in the Main menu.

**Software** shows you the name of the current software.

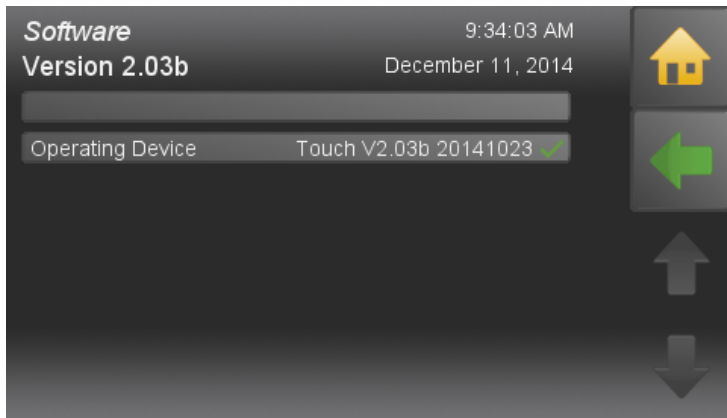

# 21 Emptying the ash pan

## CAUTION

Risk of burns  
Do not touch the boiler vessel. Use gloves.

## DANGER

Risk of fire  
Bring out the ash pan immediatly.  
Do not dispose ash until it has completely cooled down.  
Empty ash only into a not flammable steel container.  
Do not use ash container to store waste or other material.  
Do not empty ash onto flammable floors or materials.

### Emptying the ash pan

**Note:**

Check the level of the ash pan and empty it at regularly intervals (at least every 2 weeks). No warning is displayed indicating that ash pan needs to be emptied when it is full (unlike external ash box)

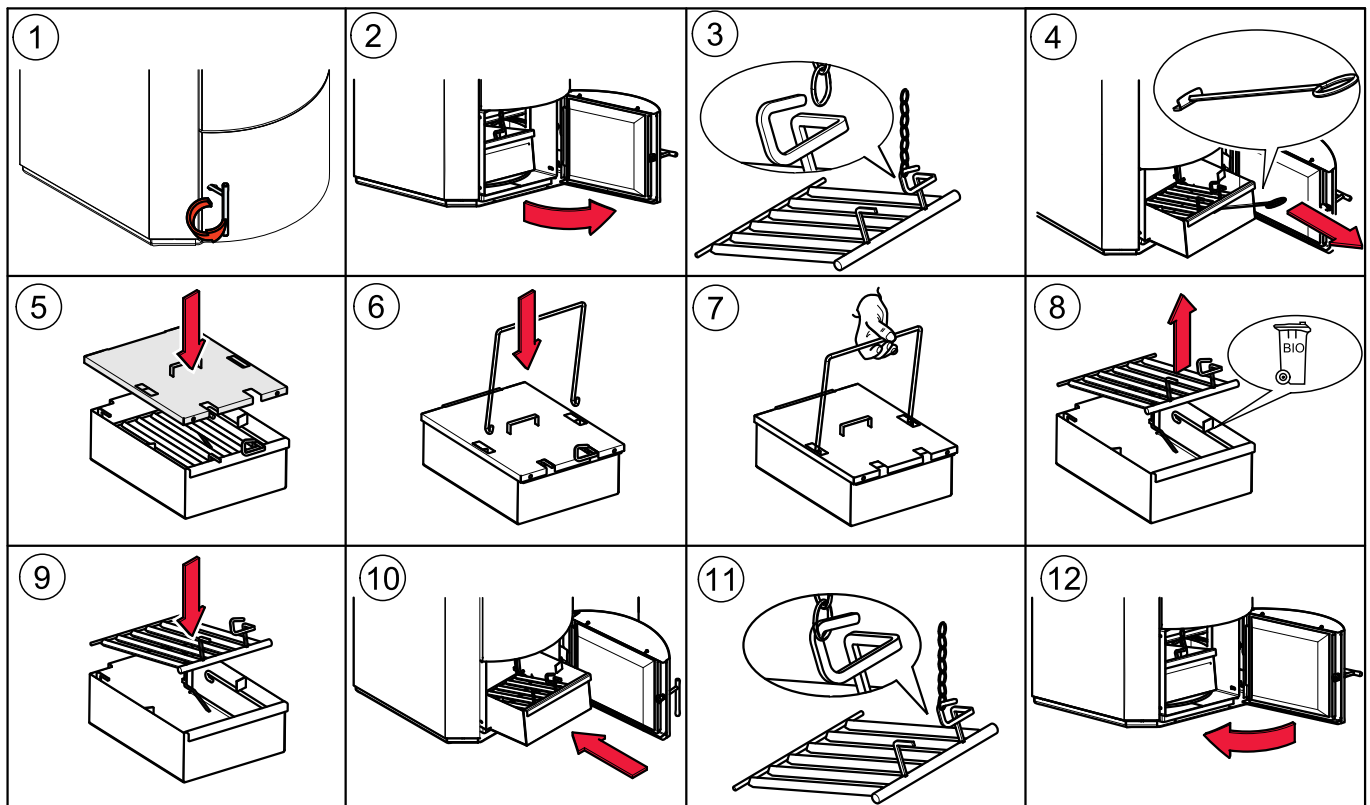
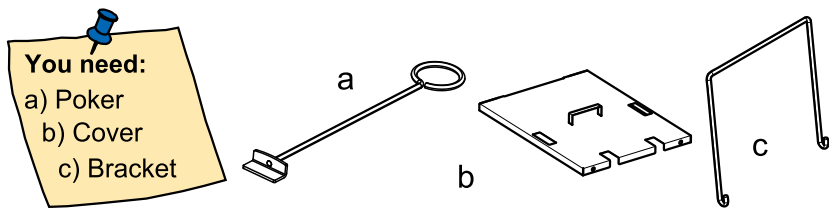

\* No riddle grate for systems with burner plate cleaning system.

## 22 Emptying the ash box

**Only on boilers with external ash box.** We also offer an optional automatic external ash box. This compresses the ash and reduces the frequency at which it needs to be emptied. It enables the ash to be disposed off without creating dust. Installation is performed by the service technician when the pellet boiler is installed. An external ash box can also be retrofitted.

### NOTICE

#### Damage to property

Empty the ash box before a longer off-time of the boiler. Otherwise the auger and the opening mechanism can be blocked through firmly bonded ash.



### DANGER

#### Risk of fire

Bring out the ash box immediately.  
Do not dispose ash until it has completely cooled down.  
Empty ash only into a not flammable steel container.  
Do not use the ash container to store waste or other material.  
Do not empty ash onto flammable floors or materials.

**Emptying the ash box**

**Note:**

When the ashbox is full then **Ash!!!** appears on the display with the alarm text **Ash box full**. After emptying and restarting the ash box the alarm text disappears automatically.

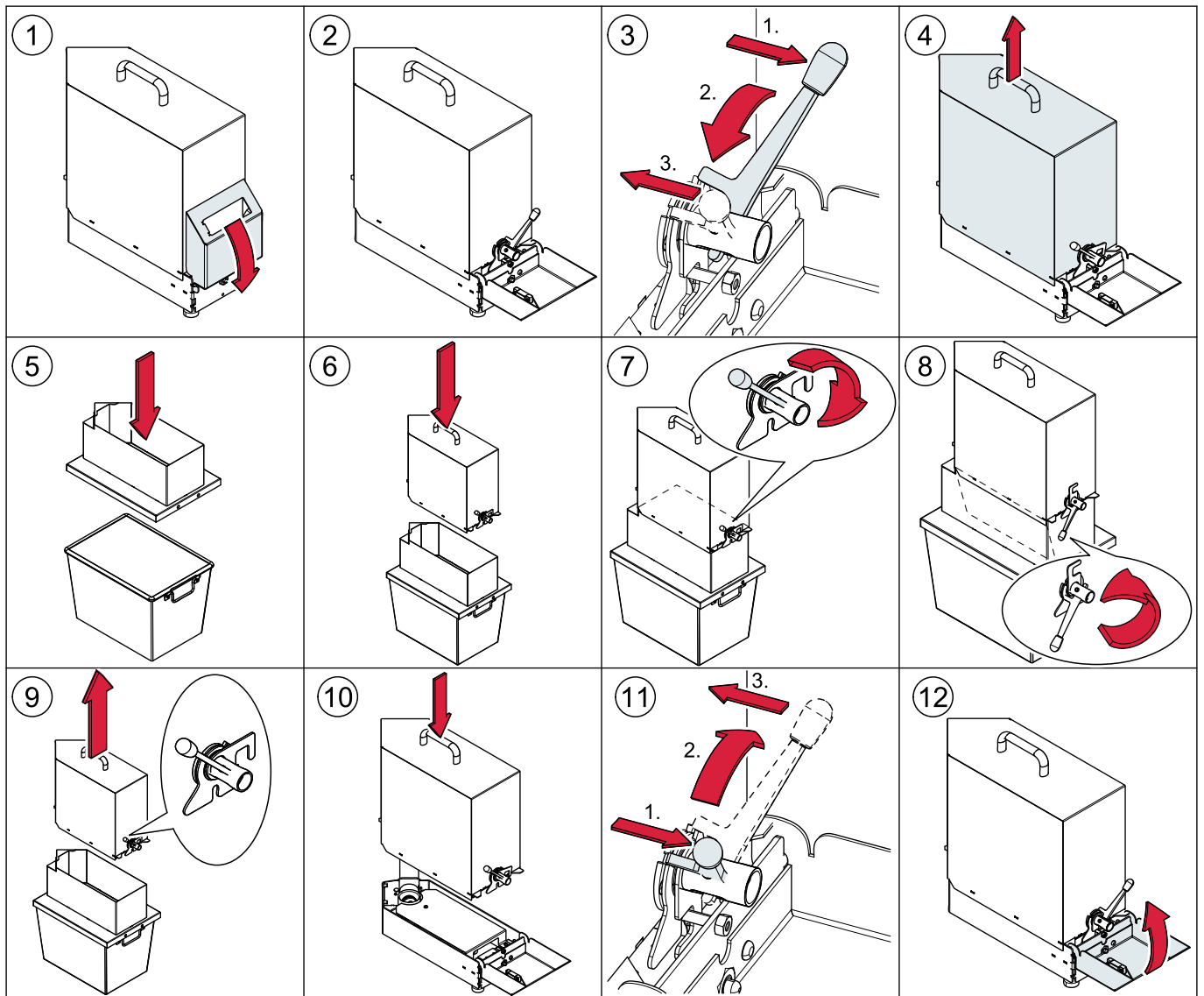
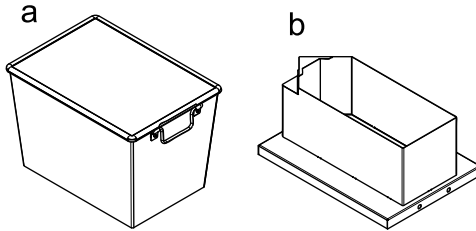
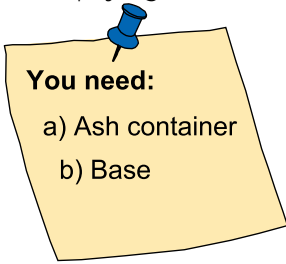



## 23 Maintenance and servicing

Regular checks of the pellet heating system are a prerequisite for reliable, efficient and environment-friendly operation.

### NOTICE

This wood heating appliance needs periodic inspection and repair for proper operation. It is against federal law to operate this wood heating appliance in a manner inconsistent with operating instructions in the manual.

### 23.1 Maintenance

The maintenance, boiler cleaning and cleaning of flue gas connection it is necessary at least once a year. For PE(S) 36-56 it is necessary in any case at least every 2000 operating hours. Pellets which produces tendentially more slagging (ash melting point  $<2372$  °F) and pellets with higher bulk density ( $> 650$ kg) leads to additional cleaning of the burner plate at regular intervals.

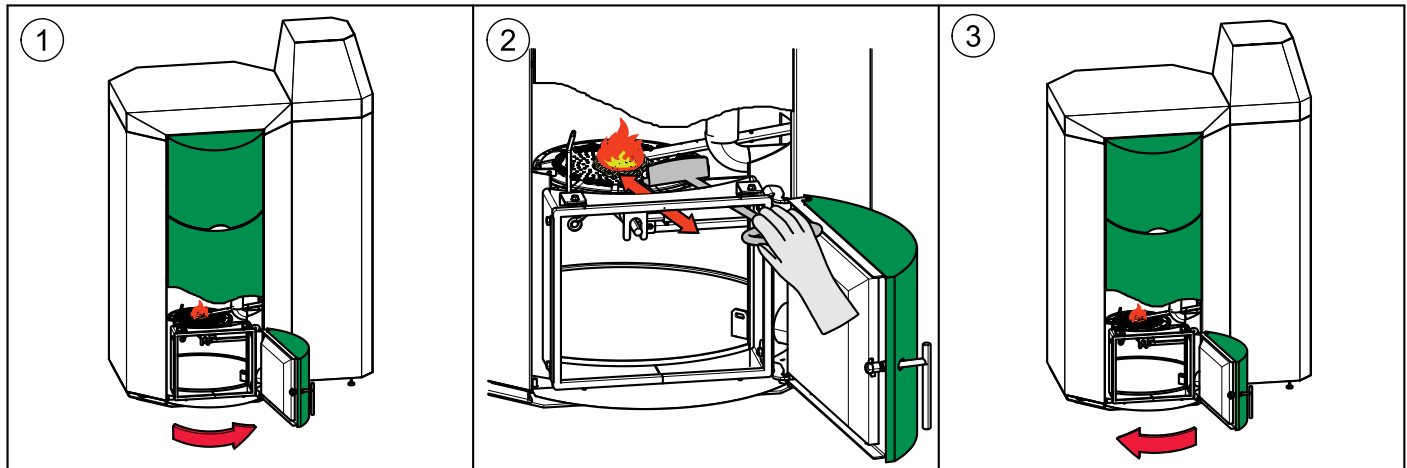

## 23.2 Cleaning the boiler every year

### NOTICE

The pellet boiler is equipped with an automatic cleaning system that cleans the heat exchanger every day. In addition, you need to clean the boiler manually once a year before the start of the heating season.

### NOTICE

Cleaning of the pellet boiler has to be performed from a authorized service technician at least every third year.



### WARNING

#### Risk of burns

Do not clean the boiler until it has been allowed to cool down.

Switch off the heating system at least 6 hours before opening the boiler.

Switch off the main switch before starting any maintenance work on the system.



### CAUTION

Risk of cut injuries due to sharp edges

Use gloves.

#### Note:

Check first of all, if all seals are in a good condition and the doors closes tightly.

### Procedure for cleaning the boiler

#### You need:

- a) Brush
- b) Poker
- c) Vacuum cleaner with ash filter

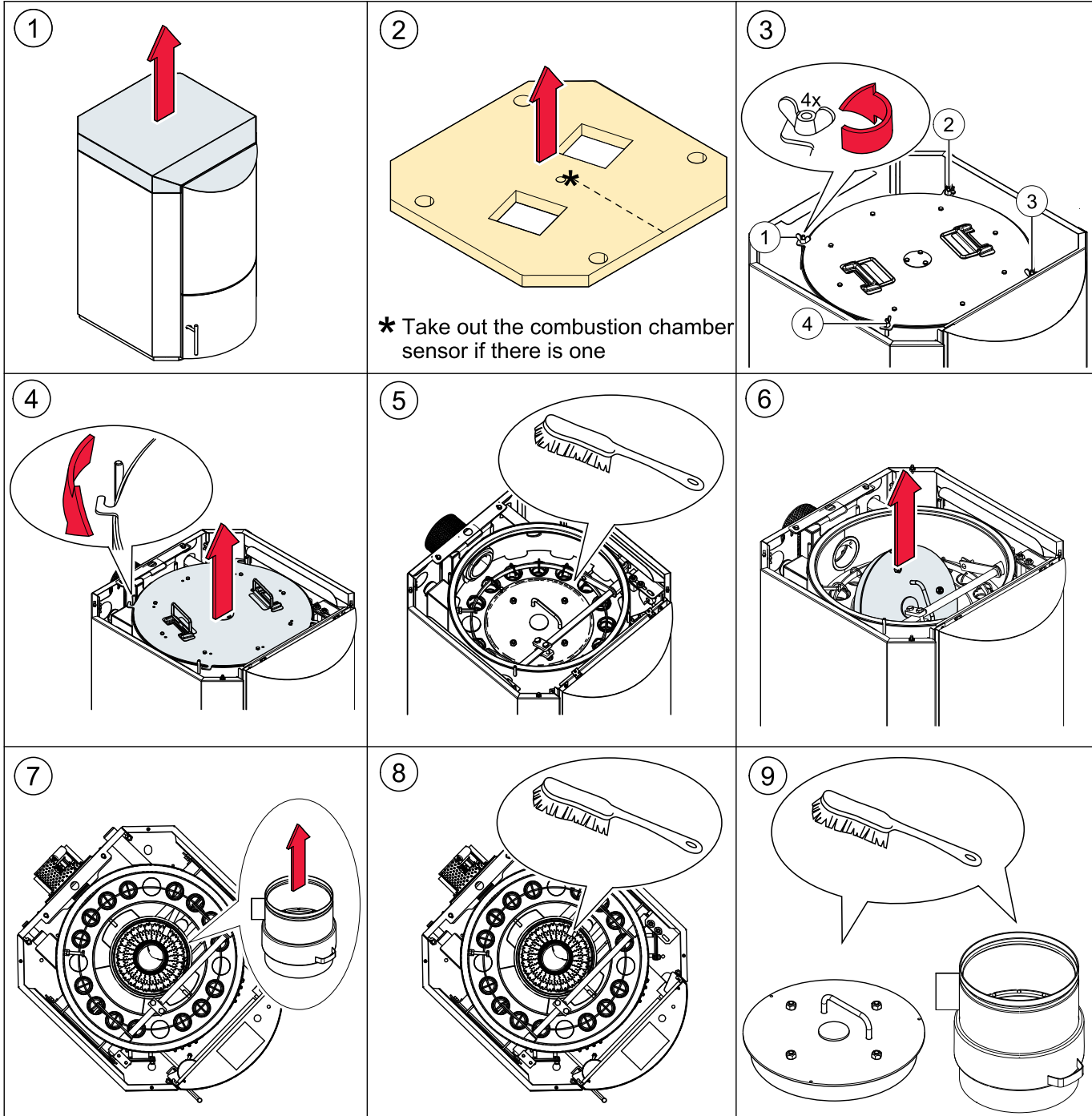
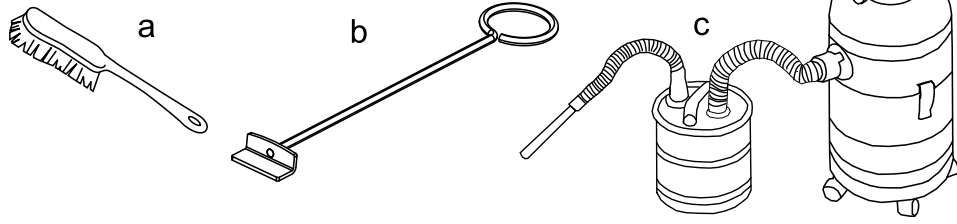

## NOTICE

Reduction in boiler performance and damage to pellet boiler due to blockages in the air inlet  
Clean the air intakes, the burner plate and the flame tube.

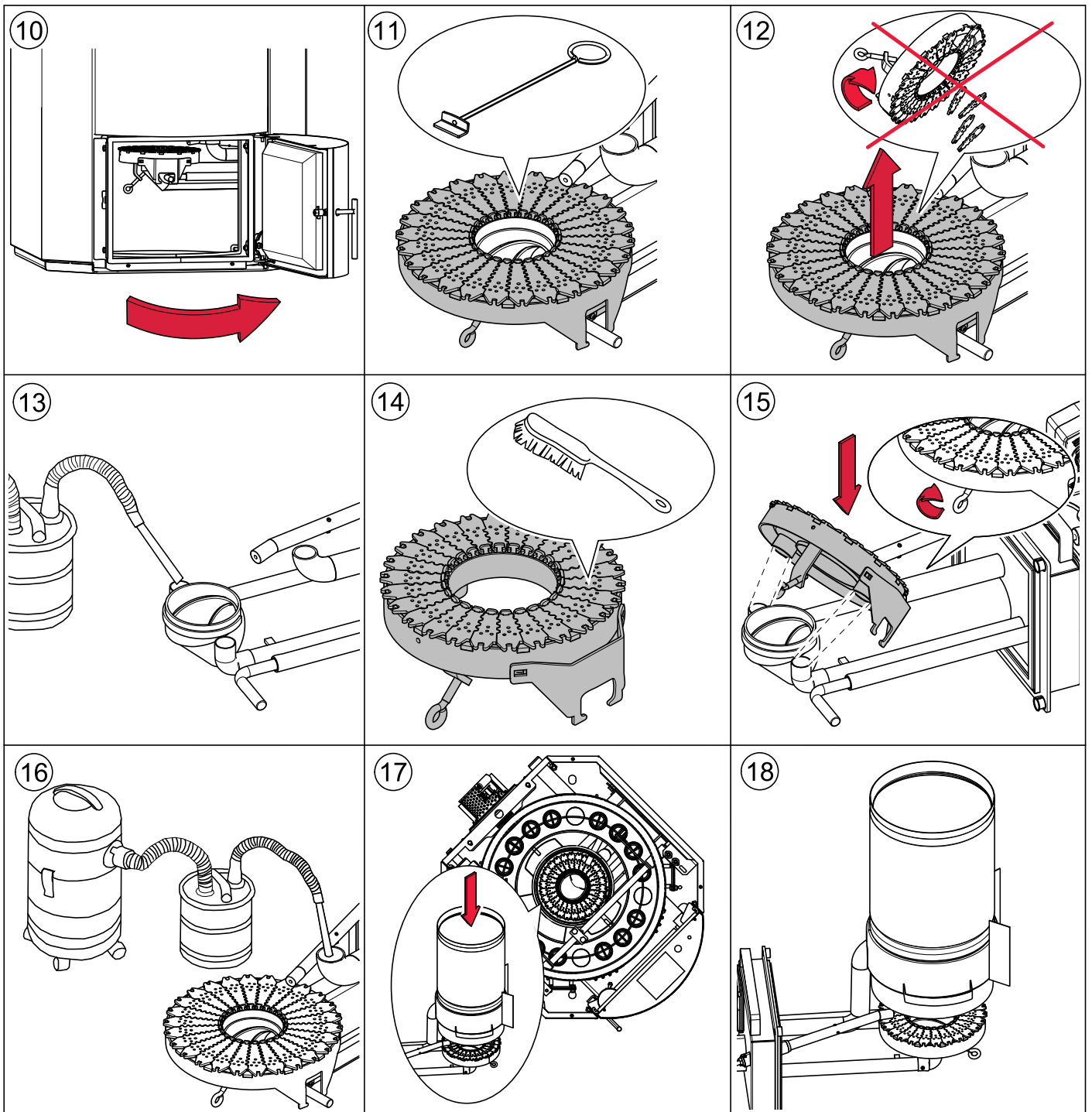

**Note:**

The individual parts of the multi segmented brazier may not be in raised position!

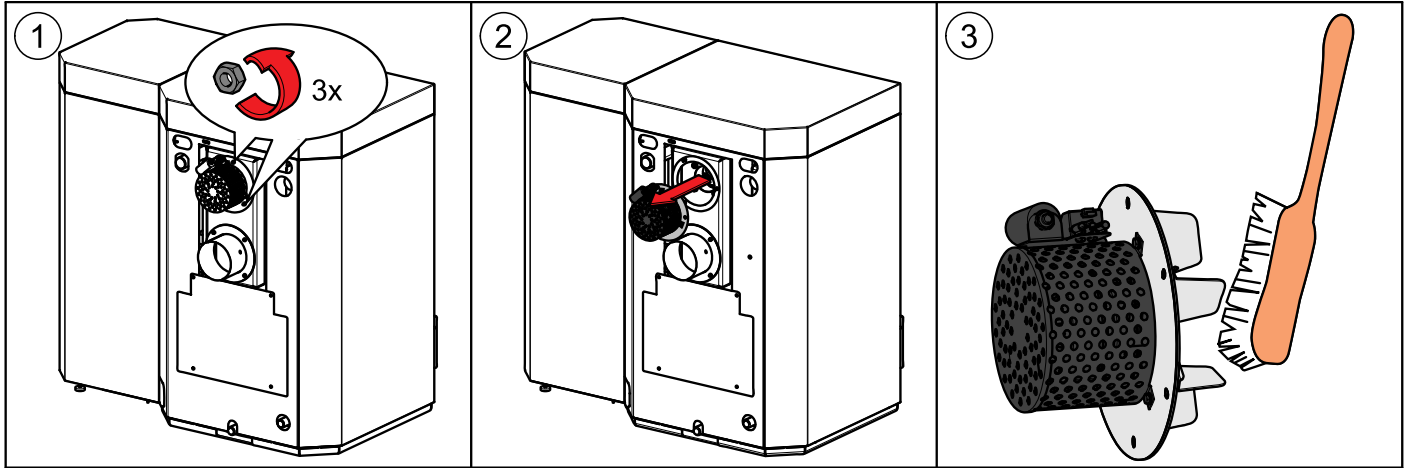
**Cleaning the Induced draft blower:**

## 23.3 Maintenance intervals

We recommend taking out a maintenance contract with your service technician.

## 23.4 Repairs



Only authorised specialists may carry out repair work on this system. Use original spare parts only. Not using original spare parts will cause the warranty to become void.

## 23.5 Checking the boiler room and storage room

Checking the pellet heating system regularly prevents malfunctions and unexpected failure of the heating system.

### Boiler room

Make sure that no flammable materials are stored in the boiler room.

Make sure that no washing is hanging in the boiler room.

Check the display on the control panel for malfunction messages.

Check the flue gas tube and chimney. Clean it regularly.

Maintenance clearances as given in Installation Manual must be observed at all times.

Do not store fuel or any other materials within these clearances.

### Storage room



## DANGER

### Risk of suffocation

Ventilate the pellet storage room sufficiently before entering.

Switch off the heating system before entering.

Check the level of pellets in the textile tank and order more pellets in good time.

# Data for 20KW model, including emissions



**MESys**  
 Maine Energy Systems, LLC  
 8 Airport Road, Bethel, Maine 04217  
 Voice: 207.824.6749 Fax: 207.824.4816

Report No. 0444PB004S

<b>Type:</b> Pellematic20		<b>S/N:</b> XUT xx	<b>CATALOG No.:</b> PES20
<b>Date of manuf.:</b> 02/2018		<b>Rated heat power:</b> 68,3000BTU/hr	
<b>Tested to:</b> UL 2523-2013. CSA B366.1-2011 EN303-5			
<b>Manufactured By:</b> MESys LLC, Bethel, Maine		<b>FUEL:</b> WOOD PELLETS	
U.S. ENVIRONMENTAL PROTECTION AGENCY certified to comply with the 2020 particulate emissions standard using wood pellets.			
This appliance needs periodic inspection and repair for proper operation. Consult owner's manual for further information. It is against federal regulations to operate this appliance in a manner inconsistent with operating instructions in the owners manual.			
<b>Particulate Emissions,</b> 0.028 lb./million btu - 0.227 grams/hr. <b>CO emissions,</b> 0.019 grams/min. <b>Annual Efficiency, (HHV)</b> 74.3%			
<b>Water Capacity:</b> 15.0 Gallons		<b>Operating Temp:</b> 194 °F	
<b>Max Operating Pressure:</b> 3 BAR / 43.5 PSI / 1204 inches WC			
<b>Chimney</b>		Approved factory built stainless steel or tile-lined masonry	
<b>MAX DRAFT:</b> 0.11 inches WC <b>MIN DRAFT:</b> 0.04 inches WC			
<b>Diameter:</b> 6 INCH		<b>Electrical Rating:</b> 220 V, 60 Hz, 14 A, 1760 W	
<b>FLOORING:</b> COMBUSTIBLE FLOORS CAN BE USED WITH A NON-COMBUSTIBLE SHIELD. MINIMUM CLEARANCES ARE 18IN/457MM IN THE FRONT AND 8IN / 203MM ON EACH SIDE.			
<b>PARTS</b>	<b>Fan Flue Gas:</b> E1001A	<b>Controller Display:</b> E1330	
<b>Motor Ash Box:</b> E1302	<b>Motor Flame Return Protection:</b> E1413A		
<b>Motor Cleaning Device:</b> E1054		<b>Motor Hopper:</b> NA	
<b>Motor Burner Plate Cleaning:</b> NA		<b>Suction Turbine:</b> E1205	
<b>Motor Burner Screw:</b> E1030		<b>Low Water Cut Off:</b> Safgard 550SV	
<b>Controller Board:</b> E1412		<b>Pressure-Relief Valve:</b> Watts Co335M1	
<b>Motor Auger Screw:</b> FKAEM 150 / FKAE-S		<b>Fan Burner:</b> E1005S	

# Data for 32KW model, including emissions



**MESys**  
 Maine Energy Systems, LLC  
 8 Airport Road, Bethel, Maine 04217  
 Voice: 207.824.6749 Fax: 207.824.4816

Report No. 0444PB004S

<b>Type:</b> Pellematic32		<b>S/N:</b> XUT xx	<b>CATALOG No.:</b> PES32
<b>Date of manuf.:</b> 02/2018		<b>Rated heat power:</b> 109,000 BTU/hr	
<b>Tested to:</b> UL 2523-2013. CSA B366.1-2011 EN303-5			
<b>Manufactured By:</b> MESys LLC, Bethel, Maine		<b>FUEL:</b> WOOD PELLETS	
U.S. ENVIRONMENTAL PROTECTION AGENCY certified to comply with the 2020 particulate emissions standard using wood pellets.			
This appliance needs periodic inspection and repair for proper operation. Consult owner's manual for further information. It is against federal regulations to operate this appliance in a manner inconsistent with operating instructions in the owners manual.			
<b>Particulate Emissions,</b> 0.021 lb./million btu - 0.319 grams/hr. <b>CO emissions,</b> 0.025 grams/min. <b>Annual Efficiency,</b> (HHV) 76.5%			
<b>Water Capacity:</b> 23.6 Gallons		<b>Operating Temp:</b> 194 °F	
<b>Max Operating Pressure:</b> 3 BAR / 43.5 PSI / 1204 inches WC			
<b>Chimney</b>	Approved factory built stainless steel or tile-lined masonry		
<b>MAX DRAFT:</b> 0.11 inches WC <b>MIN DRAFT:</b> 0.04 inches WC			
<b>Diameter:</b> 6 INCH		<b>Electrical Rating:</b> 220 V, 60 Hz, 14 A, 1760 W	
<b>FLOORING:</b> COMBUSTIBLE FLOORS CAN BE USED WITH A NON-COMBUSTIBLE SHIELD. MINIMUM CLEARANCES ARE 18IN/457MM IN THE FRONT AND 8IN / 203MM ON EACH SIDE.			
<b>PARTS</b>	<b>Fan Flue Gas:</b> E1001A	<b>Controller Display:</b> E1330	
<b>Motor Ash Box:</b> E1302		<b>Motor Flame Return Protection:</b> E1413A	
<b>Motor Cleaning Device:</b> E1054		<b>Motor Hopper:</b> NA	
<b>Motor Burner Plate Cleaning:</b> NA		<b>Suction Turbine:</b> E1205	
<b>Motor Burner Screw:</b> E1030		<b>Low Water Cut Off:</b> Safgard 550SV	
<b>Controller Board:</b> E1412		<b>Pressure-Relief Valve:</b> Watts Co335M1	
<b>Motor Auger Screw:</b> FKAEM 150 / FKAE-S		<b>Fan Burner:</b> E1005S	



# Data for 56KW model, including emissions



**MESys**  
 Maine Energy Systems, LLC  
 8 Airport Road, Bethel, Maine 04217  
 Voice: 207.824.6749 Fax: 207.824.4816

Report No. 0444PB004S

<b>Type:</b> Pellematic56		<b>S/N:</b> XUT xx	<b>CATALOG No.:</b> PES56
<b>Date of manuf.:</b> 02/2018		<b>Rated heat power:</b> 191000BTU/hr	
<b>Tested to:</b> UL 2523-2013. CSA B366.1-2011 EN303-5			
<b>Manufactured By:</b> MESys LLC, Bethel, Maine		<b>FUEL:</b> WOOD PELLETS	
U.S. ENVIRONMENTAL PROTECTION AGENCY certified to comply with the 2020 particulate emissions standard using wood pellets.			
This appliance needs periodic inspection and repair for proper operation. Consult owner's manual for further information. It is against federal regulations to operate this appliance in a manner inconsistent with operating instructions in the owners manual.			
<b>Particulate Emissions,</b> 0.045lb./million btu - 0.904grams/hr. <b>CO emissions,</b> 0.027grams/min. <b>Annual Efficiency,</b> (HHV) 86.3%			
<b>Water Capacity:</b> 30.6 Gallons		<b>Operating Temp:</b> 194 °F	
<b>Max Operating Pressure:</b> 3 BAR / 43.5 PSI / 1204 inches WC			
<b>Chimney</b>	Approved factory built stainless steel or tile-lined masonry		
<b>MAX DRAFT:</b> 0.11 inches WC <b>MIN DRAFT:</b> 0.04 inches WC			
<b>Diameter:</b> 7 INCH		<b>Electrical Rating:</b> 220 V, 60 Hz, 14 A, 1760 W	
<b>FLOORING:</b> COMBUSTIBLE FLOORS CAN BE USED WITH A NON-COMBUSTIBLE SHIELD. MINIMUM CLEARANCES ARE 18IN/457MM IN THE FRONT AND 8IN / 203MM ON EACH SIDE.			
<b>PARTS</b>	<b>Fan Flue Gas:</b> E1249A	<b>Controller Display:</b> E1330	
<b>Motor Ash Box:</b> E1302		<b>Motor Flame Return Protection:</b> E1413A	
<b>Motor Cleaning Device:</b> E1054		<b>Motor Hopper:</b> E1197	
<b>Motor Burner Plate Cleaning:</b> E1204		<b>Suction Turbine:</b> E1205	
<b>Motor Burner Screw:</b> E1306		<b>Low Water Cut Off:</b> Safgard 550SV	
<b>Controller Board:</b> E1412		<b>Pressure-Relief Valve:</b> Watts Co335M1	
<b>Motor Auger Screw:</b> FKAEM 150 / FKAE-S		<b>Fan Burner:</b> E1005S	

# General information

As required by the United States Department of Environmental Protection the following information is given for the:

**AutoPellet Pellematic PES 10-56 wood pellet fired central heating boiler. Manufactured by Maine Energy Systems, of 8 Airport Road, Bethel, Maine, 04217**

- The Pellematic has a thermal output levels from 6 kW or 20,500 btu/h to 191,000 btu/h and complies with EPA 2020 requirements.
- This wood heater has a manufacturer-set minimum low burn rate that must not be altered. It is against federal regulations to alter this setting or otherwise operate this wood heater in a manner inconsistent with operating instructions in this manual.
- Complete installation information is found in the Installation Manual.
- Although operational information is elsewhere in this manual, there are specific concerns for correct operation that can directly affect the emissions profile of this equipment. It is therefore necessary that we mention these important points.
- Fuel loading and selection. Your Pellematic is equipped with completely automatic fuel loading. Thus, other than selecting the correct fuel, there are no loading instructions as such. Fuel selection is straight forward.  
Only PFI Premium 100% wood pellets should be used in your boiler.
- Among the materials that are specifically prohibited to be burned in your Pellematic are: trash, plastics, gasoline, rubber, naphtha, household garbage, material treated with petroleum products such as particleboard, railroad ties, and pressure treated wood.  
Burning these materials may result in release of toxic fumes or render the boiler ineffective and cause smoke.
- Your Pellematic pellet fired boiler is completely automatic ignition as well as the loading as before mentioned.  
There are therefore no starting procedures to be followed. The boiler correctly starts itself when required by building load.
- There are no user adjustments required for the air controls on your Pellematic.
- It is important to have your Pellematic boiler serviced by a trained professional who is aware of the importance to ensure that there are no inlet air restrictions in or around your boiler's combustion blower. And that the air passages within your boiler are free of debris, (creosote, ash, etc.)  
The flue pipe and chimney are also clean and free of debris / restrictions.  
And that the combustion chamber door seal is airtight when the door is closed and secured.
- Ash removal is also completely automatic on your Pellematic boiler. Ashes should be placed in a metal container with a tight-fitting lid.  
The closed container of ashes should be placed on a noncombustible floor or on the ground, away from all combustible materials, pending final disposal. The ashes should be retained in the closed container until all cinders have thoroughly cooled.  
When cooled ashes can be disposed of on your lawn, garden or local transfer station.
- Your Pellematic is not a catalytic type burner.
- A person or persons responsible for the operation of a hydronic heater must comply with all applicable laws or other requirements, such as State laws or regulations as well as local ordinances.
- A person or persons operating a hydronic heater should be aware that they are responsible for operation in such a manner that does not create a public or private nuisance condition.  
The Manufacturer's distance and stack height recommendations and the requirements in any applicable laws or other requirements may not always be adequate to prevent nuisance conditions due to terrain or other factors.
- Your Pellematic should be installed with a minimum stack height of 16 feet.  
Providing correct draft as given in the Installation manual.
- Draft is the force which moves air from the appliance up through the chimney.

The amount of draft in your chimney depends on the length of the chimney, local geography, nearby obstructions and other factors.

Too much draft may cause excessive temperatures in the appliance and may damage the catalytic combustor.

Inadequate draft may cause backpuffing into the room and 'plugging' of the chimney. Inadequate draft will cause the appliance to leak smoke into the room through appliance and chimney connector joints and an uncontrollable burn or excessive temperature indicates excessive draft.

- The efficiency of your 20KW Pellematic boiler, running at full power is >74%.
- The efficiency of your 32KW Pellematic boiler running at full power is >76%.
- The efficiency of your 56KW Pellematic boiler, running at full power is >86%.
- This is the result of a laboratory test and was measured using the HHV of the fuel used.
- You should never operate a combustion appliance of any type in your home without there being a properly installed smoke and CO detector.  
Your local fire department usually has good advice on placement of these detectors and how many your home may need for complete coverage.

## Author & Manufacturer

MAINE ENERGY SYSTEMS LLC  
8 Airport Road — P.O. Box 547 Bethel  
Maine 04217

E-Mail: [info@maineenergysystems.com](mailto:info@maineenergysystems.com)  
[www.maineenergysystems.com](http://www.maineenergysystems.com)

© MAINE ENERGY SYSTEMS LLC  
Subject to modifications

Please read carefully prior  
to installing and servicing.

SAVE THESE INSTRUCTIONS

# Installation Manual

Pellet heating with vacuum  
suction system, type

**AutoPellet®**  
**PES 10 – 32**

---

FA\_V2.03

AutoPelletTOUCH

---

USA



Title: Installation Manual AutoPellet® PES 10 – 32

Article number: PE 199 USA 2.0

Version valid  
from: 03/2015

Approved: Wohlinger Christian

## Author & Manufacturer

MAINE ENERGY SYSTEMS LLC  
8 Airport Road – P.O. Box 547 Bethel  
Maine 04217

E-Mail: [info@maineenergysystems.com](mailto:info@maineenergysystems.com)  
[www.maineenergysystems.com](http://www.maineenergysystems.com)

© MAINE ENERGY SYSTEMS LLC  
Subject to modifications

<b>1</b>	<b>Dear Customer</b> .....	<b>5</b>
<b>2</b>	<b>Use only for the purpose intended</b> .....	<b>6</b>
<b>3</b>	<b>Types of safety warning sign</b> .....	<b>7</b>
<b>4</b>	<b>Warnings and safety instructions</b> .....	<b>8</b>
4.1	Basic safety instructions .....	8
4.2	Warning signs.....	8
4.3	What to do in an emergency.....	10
<b>5</b>	<b>Prerequisites for installing a pellet boiler</b> .....	<b>11</b>
5.1	Guidelines and standards for installing a pellet boiler .....	11
5.2	Boiler room.....	11
5.3	Flue gas system.....	12
5.4	Safety systems .....	14
5.5	Installation with an existing boiler.....	15
<b>6</b>	<b>Product description</b> .....	<b>16</b>
6.1	The pellet boiler.....	17
6.2	Pellet suction system .....	19
6.2.1	Assembly of the vacuum system.....	19
6.3	Storage systems.....	21
6.3.1	Flexilo textile tank.....	21
<b>7</b>	<b>Bringing the pellet boiler into the boiler room</b> .....	<b>22</b>
7.1	Transport.....	22
7.2	Notes on bringing the unit into the building .....	22
7.3	Flooring .....	26
7.4	Casing parts .....	27
7.5	Removing the casing, the hopper and the burner .....	28
7.5.1	Dismantling the burner casing .....	28
7.5.2	Dismantling the hopper.....	29
7.5.3	Dismantling the burner.....	30
7.5.4	Dismantling the boiler door .....	32
7.5.5	Dismantling the boiler casing.....	33
<b>8</b>	<b>External de-ashing / automatic ash compaction system</b> .....	<b>35</b>
8.1	Description of de-ashing system .....	35
8.2	Installing the de-ashing system.....	36
8.2.1	Bringing in and installing de-ashing system on the base plate .....	36
8.2.2	Installing the ash auger, fitting the sub-assembly and mounting the door plate.....	37
8.2.3	Installing the burner side casing with cut-out and electrical connection.....	38
8.2.4	Assembling the pellet boiler and activating the ash box.....	39
<b>9</b>	<b>Connecting up the hydronics</b> .....	<b>40</b>
9.1	Hydronic connecting diagrams.....	41
<b>10</b>	<b>Connecting to the power supply</b> .....	<b>42</b>
10.1	Terminal box .....	42
10.1.1	Wiring diagram - terminal box .....	42
10.2	Plugs on the boiler control unit.....	45
10.3	Cable routing .....	47
10.4	Wiring diagrams .....	50
10.5	Fuses - boiler controller .....	54
10.6	Operating the AutoPellet .....	54
<b>11</b>	<b>Starting up for the first time</b> .....	<b>55</b>
11.1	Adjusting power rating .....	55
11.1.1	Installing the turbulators and closure plugs .....	55
<b>12</b>	<b>Appendix</b> .....	<b>57</b>
12.1	Checklist for checking the heating system .....	57
12.2	Appendix G of CAN/CSA-B365-M91 .....	59
12.3	Modifying the burner.....	60
12.3.1	Dismantling the casing, hopper, combustion chamber lid, flame tube, and burner.....	60
12.3.2	Modify the burner on the left .....	61
12.3.3	Modifying the cleaning system motor and off-set disc .....	62

12.3.4 Changing the direction of rotation of the cleaning motor ..... 63

12.3.5 Modifying and re-assembling the cleaning system ..... 63

12.4 Parts list..... 65

    12.4.1 Pellematic PES 10 - 20 34,000 - 68,300 BTU/hr..... 65

    12.4.2 Pellematic PES 25 - 32 / Boiler 85,300 - 109,500 BTU/hr..... 69

12.5 Technical data .....73

12.6 Pellet boiler cautionary markings .....77

# 1 Dear Customer

**Maine Energy Systems** specializes in wood pellet heating, our company enjoys an exclusive license from ÖkoFEN to manufacture AutoPellet boilers here in the USA. We represent expertise, innovation and quality. We are delighted that you have decided to purchase our product.

- This instruction manual is intended to help you operate the product safely, properly and economically.
- Please read this instruction manual completely and take note of the safety warnings.
- Keep all documentation supplied with this unit in a safe place for future reference.  
Please pass on the documentation to the new user if you decide to part with the unit at a later date.
- Installation and first start up must be carried out by an installer certified by Maine Energy Systems.
- Please contact your authorised dealer if you have any questions.



We place great importance on the development of new products. Our R&D department continues to question accepted solutions and works continually on new improvements. That is how we maintain our technological lead. We have already received several awards for our products in Austria and abroad. Our products fulfil European and USA requirements regarding quality, efficiency and emissions.





## **2 Use only for the purpose intended**

The pellet boiler is designed to heat water for central or other indirect heating systems and hot water supply for buildings. It is not permissible to use the pellet boiler for any other purpose. Reasonable foreseeable inadvertent uses for the pellet boiler are not known.

The boiler fulfils the requirements of UL 2523-2013 and CSA B366.1-2011.

## 3 Types of safety warning sign

The warning signs use the following symbols and text.

### Types of safety warning sign

1. Risk of injury
2. Consequences of risk
3. Avoiding risk



#### 1. Risk of injury:

Danger - indicates a situation that could lead to death or life-threatening injury.



Warning - indicates a situation that could lead life-threatening or serious injury.



Caution - indicates a situation that could lead to injury.



Note - indicates a situation that could lead to property damage.



#### 2. Consequences of risk

Effects and consequences resulting from incorrect operation.

#### 3. Avoiding risk

Observing safety instructions ensures that the heating system is operated safely.

## 4 Warnings and safety instructions

Observing safety instructions ensures that the heating system is operated safely.

### 4.1 Basic safety instructions

- Never get yourself into danger; give your own safety the utmost priority.
- Keep children away from the boiler room and storage room.
- Observe all safety warnings on the boiler and in this user manual.
- Observe all instructions relating to maintenance, servicing and cleaning.
- The pellet heating system may only be installed and started up for the first time by an authorised installer. Professional installation and start up is the prerequisite for safe and economical operation.
- Never make any changes to the heating system or flue gas system.
- Never close or remove safety valves.

### 4.2 Warning signs

 <b style="font-size: 1.5em; margin-left: 10px;">DANGER</b>
<p><b>Risk of poisoning</b>          Make sure that the pellet boiler is supplied with sufficient combustion air.          The openings in the combustion air inlet must never be partially or completely closed.          Ventilation systems, central vacuum cleaning systems, extractor fans, air conditioning systems, flue gas blowers, dryers, fuel storage ventilation fans or similar equipment must never be allowed to draw air from the boiler room and cause a drop in pressure.          The boiler must be connected tight to the chimney using a flue gas tube.          Clean the chimney and the flue gas tube at regular intervals.          The boiler room and pellet storage room must be sufficiently supplied with air and ventilated.          Before entering the storage room it must be ventilated with sufficient air and the heating system switched off</p>

 <b style="font-size: 1.5em; margin-left: 10px;">DANGER</b>
<p><b>Risk of electric shock</b>          Only an authorised installer may connect the pellet boiler to the power supply.          Always disconnect / de-energize the power supply before working on the boiler.</p>

 <b style="font-size: 1.5em; margin-left: 10px;">DANGER</b>
<p><b>Risk of explosion</b>          DO NOT BURN GARBAGE, GASOLINE, NAPHTHA, ENGINE OIL, OR OTHER INAPPROPRIATE MATERIALS.          DO NOT USE CHEMICALS OR FLUIDS TO START THE FIRE.          Switch off the heating system before filling the storage room.</p>



## DANGER

### Risk of fire

Do not store any flammable materials in the boiler room.  
Do not hang out any washing in the boiler room.  
Do not operate with fuel loading or ash removal doors open.



## WARNING

### Risk of burns

Do not touch the flue gas connector or flue gas pipe.  
Do not reach into the ash chamber.  
Use gloves to empty ash box if boiler not equipped with automatic ash compression  
Do not clean the boiler until it has been allowed to cool down.



## CAUTION

### HOT SURFACES

Keep children away.  
Do not touch during operation.  
Do not operate if maximum draft as listed on boiler nameplate is exceeded.  
Doing so can allow non-controlled combustion.



## CAUTION

### Risk of cut injuries due to sharp edges.

Use gloves for performing all work on the boiler.

## NOTICE

### Damage to property

The pellet boiler is suitable only for pellets which comply with PFI premium or EnPlus -A1 pellets specifications.  
The use of any other fuel voids your warranty and can cause damage to the pellet boiler and chimney.

## NOTICE

### Damage to property

Do not use the heating system if it, or any of its components, come into contact with water.  
If water damage occurs, check the heating system by an authorized service technician and replace damaged parts.



## WARNING

All cover plates, enclosures, and guards must be maintained in place at all times, except during maintenance and servicing.

## 4.3 What to do in an emergency



### DANGER

**Risk to life**

Never get yourself into danger; give your own safety the utmost priority.

**What to do in the event of a fire**

- Switch off the heating system.
- Call your local fire department and or 911.
- Use approved fire extinguishers (fire protection class ABC).

**What to do if you smell smoke**

- Switch off the heating system.
- Close the doors leading to living areas.
- Ventilate the central heating room.

## 5 Prerequisites for installing a pellet boiler

You must fulfil the following conditions before operating a fully automatic pellet boiler.

### 5.1 Guidelines and standards for installing a pellet boiler

Overview of standards and guidelines applying to the installation of a pellet boiler.

Check whether you need to obtain planning permission or approval from the authorities for installing a new heating system or changing your existing system. Installation must meet all requirements for pellet fired heating systems in your specific location.

### 5.2 Boiler room

The pellet boiler is installed in the boiler room.

#### 1. Safety instructions for the boiler room

	DANGER
<p><b>Risk of fire</b>            Do not store flammable materials or liquids in the vicinity of the pellet boiler.            Do not permit unauthorised persons to enter the boiler room - Keep children away.            Do not operate with fuel loading or ash removal doors open.</p>	

#### 2. Air supply and ventilation of boiler room

The boiler room must be fitted with air supply and ventilation openings (at least 31 inch<sup>2</sup>/200cm<sup>2</sup>). In any case you must comply with the state and local regulations

#### 3. Combustion air supply

The pellet boiler needs a supply of combustion air. The supply of combustion air can:

- a. take place using one or more air supply and ventilation openings in total min. 31 inch<sup>2</sup>.
- b. or through a special air supply line directly from outside, where the diameter of the air supply line must be at least 4 inch/ 100mm in for type PE(S) 12 – PE(S) 32. Ambient air independent operation of PES 36-56 types is also available on request. In any case, properly sized room ventilation is still required to allow your barometric draft controller to function properly.

Never operate the pellet boiler if the air intake openings are partially or completely closed.

Contaminated combustion air can cause damage to the pellet boiler. Never store or use cleaning detergents containing chlorine, nitrobenzene or halogen in the room where the heating system is installed, if combustion air is drawn directly from the room. It is recommended that no washing or drying of laundry is done in the boiler room or where the boiler may draw air from.

Do not hang out washing in the boiler room.

Prevent dust from collecting at the combustion air intake to the pellet boiler.

#### 4. Damage due to frost and humid air

The boiler room must be frost-proof to ensure trouble-free operation of the heating system. The temperature of the boiler room must not fall below 37°F and must not exceed 90°F. The air humidity in the boiler room must not exceed 70%.

#### 5. Danger for animals

Make sure that household pets and other small animals cannot enter the boiler room. Fit mesh over any openings.

#### 6. Flooding

If there is a risk of flooding, switch off the pellet boiler and disconnect from the power supply before water enters the boiler room. You must have all components that come into contact with water replaced, before you start up the pellet boiler again.

## 5.3 Flue gas system

The flue gas system consists of a chimney and a flue gas tube. The flue gas tube connects the pellet heating system to the chimney. The chimney leads the flue gas from the pellet heating system out into the open.

### 1. Design of the chimney

The dimensions and design of the chimney is very important. The chimney must be able to ensure sufficient draft to safely draw away the flue gas regardless of the status of the boiler. Low flue gas temperatures can cause sooting and moisture damage on chimneys that are not insulated. For this reason **moisture-resistant chimneys** (stainless steel or ceramic) should be used. An existing chimney that is not damp-resistant needs to be renovated before use. Follow guidelines below:

Boiler size		PE(S) 12 – 20	PE(S) 25 – 32	PE(S) 36 – 56
Flue gas tube diameter (at boiler)	inch/mm	5/130 or 6/150	6/150	7/180
Flue gas temp. / rated power	°F	320	320	360
Flue gas temp. / partial load	°F	212	212	230
Min. draft – full load/part load	in/wc	-0.04 / -0.02		

Chimney size	Min. Height
6in x 6in	17ft
7in x 7in	16ft
8in x 8in	16ft
6in round	19ft
7in round	17ft

Recommended and UL-103HT approved chimney materials are:

- Selkirk sure temp
- Supervent (JSC)
- Security chimneys (secure temp ASHT)

Use flue gas pipe from chimney to boiler as required by your local code.



## CAUTION

**Unregulated combustion**  
Please observe that combustion air openings and flue pipes are not reduced in size or closed. Make end user aware of these guidelines and their potential danger. Clean the chimney and the flue gas tube at regular intervals. Check if the draft inducer is clean and in a good condition.

### 2. Flue gas temperature

The flue gas temperatures are approximately the same for all Autopellet boilers covered in this manual.

The dewpoint of flue gas with wood pellets (max. 10% water content) is approx. 120°F.

It is possible to increase the flue gas temperature to prevent condensation inside the chimney and avoid damage due to damp. Only authorised installers may increase the flue gas temperature.

**Note:**

The increase in flue gas temperature results in reduced efficiency and thus increases fuel consumption.

**3. Negative pressure of the chimney**

The boiler must be connected to a chimney or a vertical venting system that is capable of handling and producing a negative breeching pressure of -0.4 "WC. Use a draft gauge to verify the indicated draft value, adjust barometric damper as required. Drill a small hole in the connection pipe at about 2in/ 50mm from the boiler flue outlet and use this hole as your measuring point.

**Chimney draft**

The suction effect of the chimney draft must extend all the way to the boiler flue pipe connection. The maximum flow rate that can be drawn through the chimney limits the maximum performance of the chimney connection. The boiler performance must be reduced if the chimney does not possess the necessary cross-section. This may only be performed by authorised personnel.

**4. Power venter**

AutoPellet boilers are approved by the manufacturer for installation with the Field Controls SWGAF power venter which is approved for wood pellet burning appliances.

Boilers installed with SWGAF power venters must follow all manufacturer’s installations and must comply with all applicable codes from agencies having authority over the installation.



**5. Cleaning**

Clean the flue gas tube and chimney regularly. Solid fuel burning appliances need to be cleaned frequently because soot, creosote, and ash may accumulate. The hotter the fire, the less creosote is deposited. Cleaning intervals can vary in warm periods due to this and become more frequent.

	<b>DANGER</b>
<b>Risk of chimney fire</b>	
Creosote-formation and need for removal: Low flue gas temperature can cause creosote. Creosote can condense in a relatively cool chimney. As a result, creosote residue accumulates on the flue lining. If ignited, this creosote will create an extremely hot fire. The chimney and the chimney connector should be inspected at least twice monthly during the heating season to determine if a creosote buildup has occurred. If creosote has accumulated it should be removed to reduce the risk of a chimney fire.	

<b>NOTICE</b>
<b>Oxidation of chimney</b>
Do not use metal brushes to clean chimneys made of stainless steel. Your state and local regulations must be observed.



## 5.4 Safety systems

The following safety measures are the prerequisite for safe operation of your system.

### Emergency stop switch

Every heating system must be able to be switched off with an Emergency Stop switch. The Emergency Stop switch must be outside of the boiler room.



### Safety valve

The hydronic system must be equipped with a safety valve. This valve opens before the pressure inside the heating system increases to max. 43 P.S.I.. The safety valve must be installed at the highest point of the boiler, must not be locked and must be within 3.28 ft / 39.37 inch/ 1m of the boiler. A 30 lb/sq in relief value is supplied with each boiler.



### Safety temperature sensor

The pellet boiler is equipped with a safety temperature sensor. This is located on the pellet boiler. If the boiler temperature exceeds 230°F then the heating system switches off.



### Low water cut off

The hydronic system must be equipped with a low water cut off. If the water level falls below a certain level, the low water cut off switches off the heating system.



## NOTICE

### Initial start-up

The initial start-up of each AutoPellet boiler must be performed by an authorized installer.

## 5.5 Installation with an existing boiler

Autopellet boilers are not to be connected to a chimney flue serving another appliance. However, when all State and local codes allow for the sharing of chimney flues, the Autopellet boilers and another appliance burning pellets or a different fuel can be operated simultaneously while connected to a single existing chimney or flue gas system providing the following conditions are met:

- All state and local codes permit the specific installation
- All appliances are installed in accordance with the manufacturer's installation specifications or if lacking manufacturers specifications, the appliance in question is installed in a manner commonly recognized as safe and correct for the application and circumstances
- The chimney or flue gas system must be able to handle the combustion products of either appliance and both appliances when operated simultaneously

### NOTICE

**Avoid clearance issues that can make servicing difficult:**

Be sure to follow suggested clearances when installing the Autopellet boiler with an existing boiler to be sure that service and cleaning can be performed adequately.



### CAUTION

**Avoid code violations:**

When connecting to or with an existing boiler, contact the authority having jurisdiction to be sure the type of installation planned is allowed.

Document the type of boiler that the Autopellet is connected to or with.

Pellet boiler: Make and Model number: \_\_\_\_\_

Existing boiler: Make and Model number: \_\_\_\_\_



### DANGER

**Possible escape of flue gas:**

Do not connect this unit to a chimney flue serving another appliance unless multiple appliances into a single flue is authorized by all authorities having jurisdiction.

## 6 Product description

The description of the product is intended to provide an overview of the components that make up a pellet heating system, the parts of the pellet boiler and advice on where you can find more information.

**The pellet heating system consists of 3 components**

1	Pellet boiler
2	Conveyor system
3	Storage system - textile tank

**Pellet boiler with textile tank**

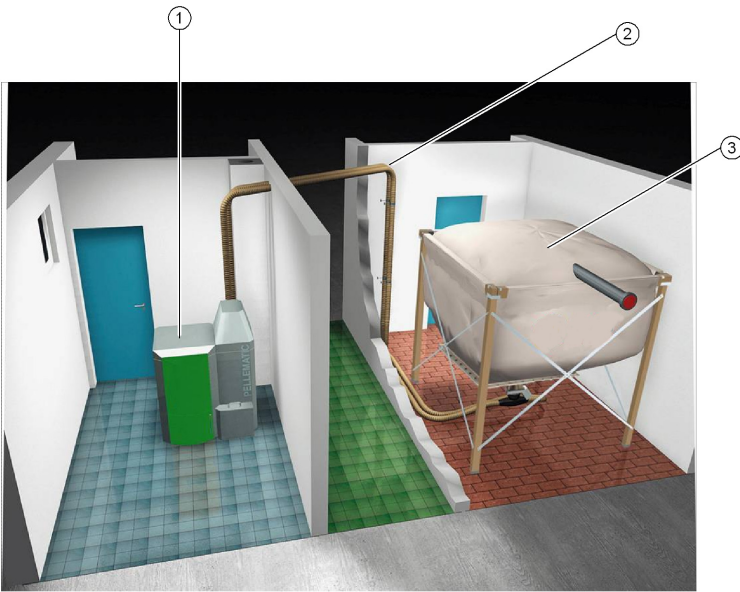

The concept features different sizes of design and type for each component. These are compatible and designed to match.

## 6.1 The pellet boiler

The pellet boiler is equipped with an automatic cleaning system, an ash box with ash compression system and an integrated return water temperature control. The installed programmable logic controller system enables fully automatic operation and highest efficiency. We offer an optional automatic de-ashing system for the highest level of cleanliness and comfort.

### Pellematic types and power ratings

We offer the Pellet boiler with the following power ratings:

Suction-feed systems: 41,000; 51,000; 68,300; 85,300; 109,500; 123,000; 164,000 and 191,000 BTU/hr

All sizes / outputs of the Autopellet boiler are available with external automatic ash compression system.

**Note:**

Refer to the data plate for the power rating of your Pellematic. The data plate is located on the rear side of the Pellematic. Here you will find the type designation, manufacturer's serial number and year of build.

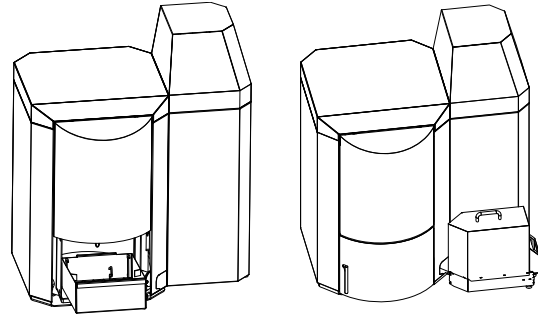

### Key components of the Pellematic

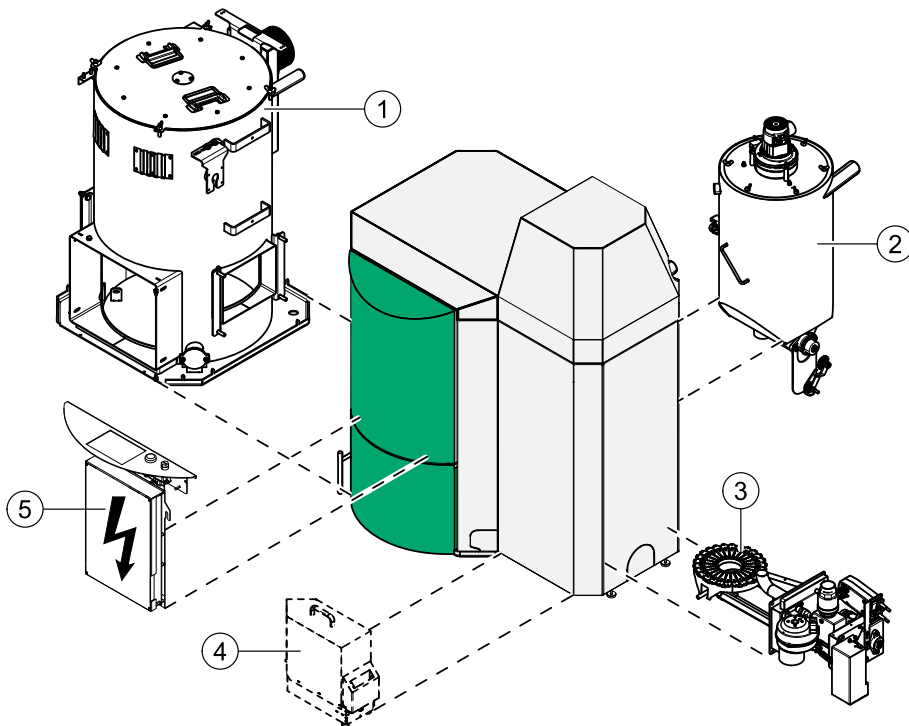

1	Boiler (heat exchanger)
2	Vac Hopper / Day tank
3	Burner
4	External automatic ash compression system
5	Boiler controller

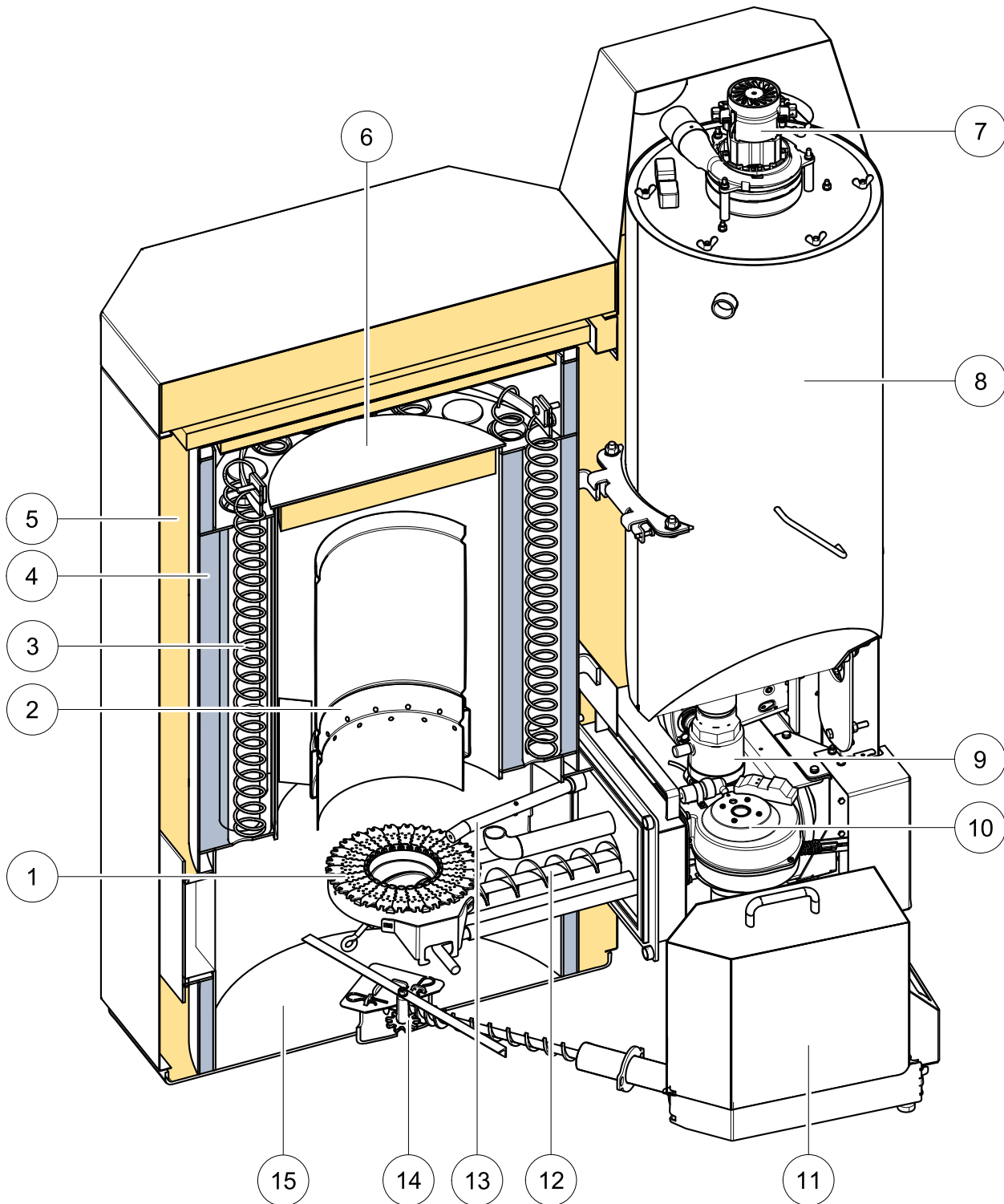

1	Burner plate	9	Fire protection - ball valve
2	Flame tube	10	Burner fan
3	Heat exchanger	11	External ash box
4	Boiler water	12	Burner auger
5	Boiler insulation	13	Electronic ignition
6	Combustion chamber cover	14	De-ashing system cover
7	Suction turbine	15	Ash chamber / Fire chamber
8	Vac hopper / Day tank		

## 6.2 Pellet suction system

The pellet suction system consists of a pellet line, an air line and a suction turbine. The suction turbine in the hopper conveys pellets in the pellet line from the storage room or textile tank to the hopper.

### Key components of pellet suction system

1	Pellet hose	Hose from textile tank to the hopper.
2	Air hose	Hosee from the suction turbine to the textile tank.
3	Suction turbine	Located above the hopper underneath the AutoPellet burner casing.
4	Suction switch	Located underneath the textile tank.

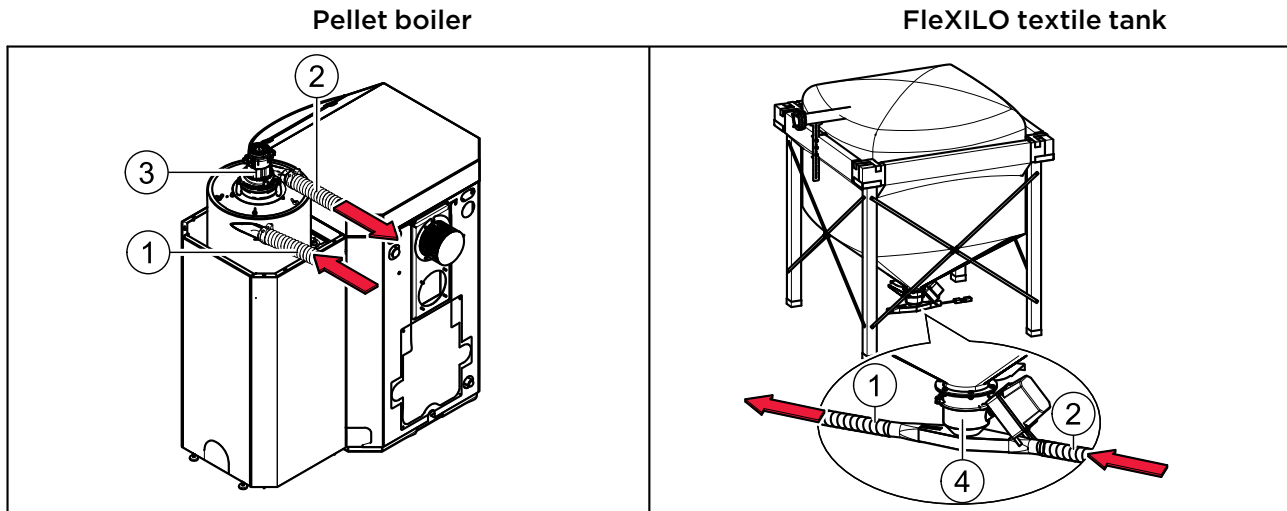

### 6.2.1 Assembly of the vacuum system

The pellet hose and the air hose are flexible spiral hoses made out of plastic. A copper braid avoids the static loading of the spiral hose.

#### To avoid damage to the spiral hose, you must observe the following assembly guidelines:

- Bending radius** The hose should be led as briefly as possible and with a few curves as necessarily. Bending radius may never be smaller than **12inch**.
- Upward gradients** Max difference in height = **236inch**  
**Note:** A difference in height of up to 118inch can be overcome at one time. Larger differences in height must be interrupted with a 4 foot horizontal run of the pellet hose.
- Impact protection** The spiral hose can be mounted up to 236inch exactly straight. In such cases however, it is very important to create a slight "S" in the pellet piping before a sharp curve to slow down the pellets to prevent hose damage.
- Installation in the soil and openings:** When installing pellet lines underground remember! The pellet lines are not designed for direct burial and require protection from being crushed or chewed by varmints. Protective piping should be minimum 4 inch and sealed at each end. There should be no bends greater than 15 degrees in the underground sections of the pellet hose.
- Tightness** To avoid problems with your pellet lines, it is important to have all hose connections secured completely air tight with hose clamps.
- Static neutralization** The hoses are provided with a copper braid, those the hose keeps antistatic. In order to ensure the function of the anti-statics, those copper braid must be attached at each end to the existing grounding become.
- Fire protection** At a wall break-through to the heating room must be installed a fire protection seal in the pellet- and the air hose.

**Crossing** The pellet hose and the air hose should cross each other as few times as possible.

**Length of the spiral hose** The maximum total length of the spiral hose is 130 feet.  
The maximum for pellet hose and air hose are each 60 feet.

**Assembly**

Use securing clips and carrying bowls.

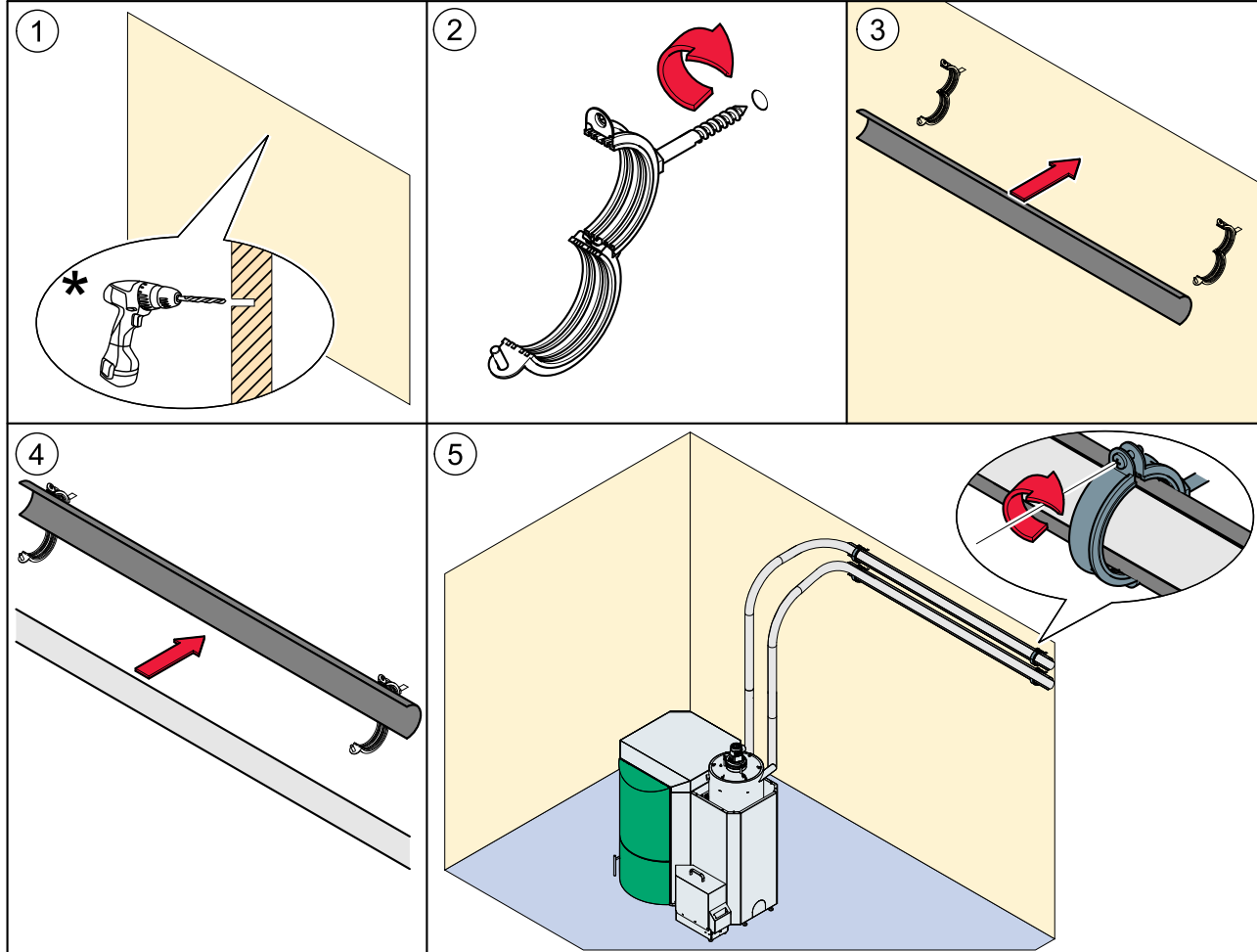

\*Pay attention to the defined distances!

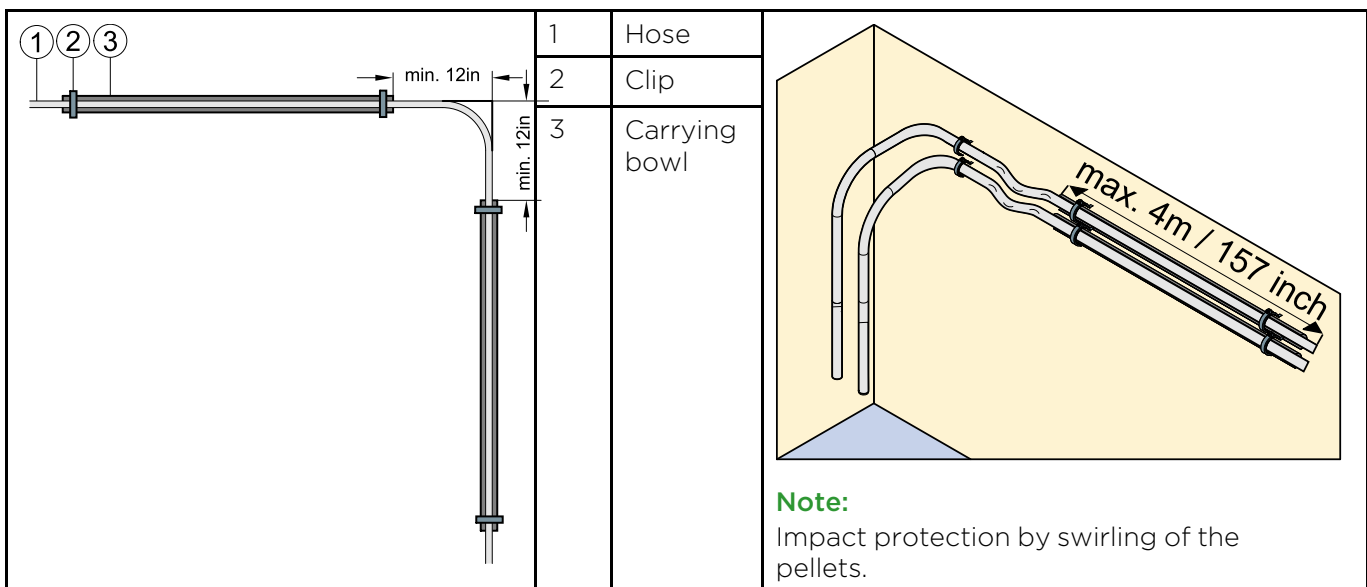

### Connection of the pellet and air hose to the suction turbine

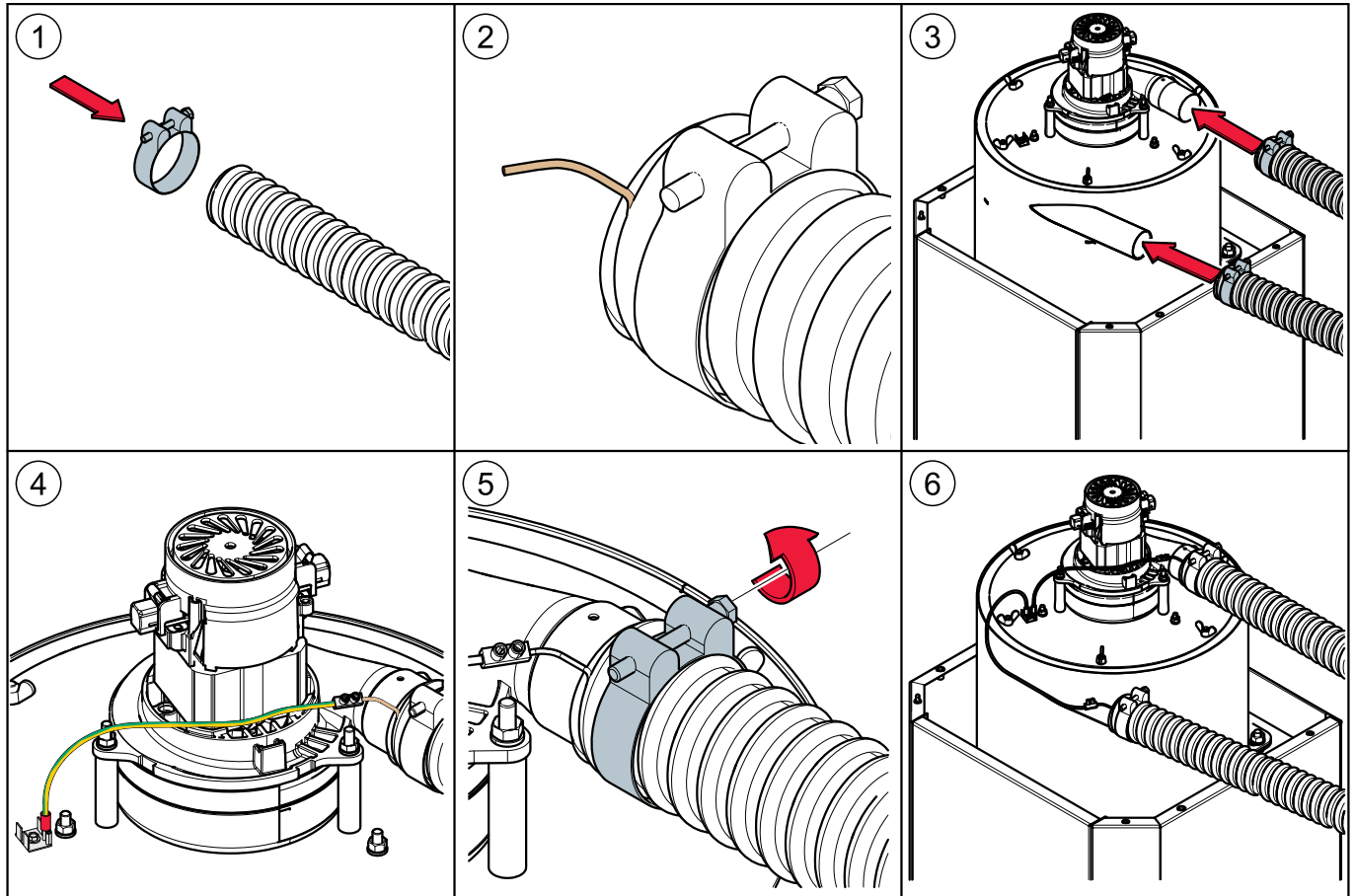

## 6.3 Storage systems

For storing pellets we offer a FlexILO textile tank. FlexILO textile tanks can be located inside the boiler room, storage room or protected from wet and sun outside.

### NOTICE

#### Damage to property and loss of warranty

The use of an AutoPellet boiler with a storage or conveyor system from another manufacturer is not permissible and will result in voiding your warranty along with undependable operation.

#### 6.3.1 Flexilo textile tank

Maine Energy Systems offers various sizes and types of fabric tanks. The fabric tank supplied may vary from the example shown above.

Please refer to the installation instructions supplied for the fabric tank. Note also the instructions on setting up and filling.



## 7 Bringing the pellet boiler into the boiler room

This section describes the prerequisites as well as the working sequence required.

1. Transport
2. Notes on bringing the unit into the building
3. Casing parts
4. Dismantling the casing parts

### 7.1 Transport

We supply the pellet boiler on a pallet. The pellet boiler is ready to be connected. The control unit for the boiler controller and the operating device is integrated into the control panel.

If it is not possible to bring the boiler into the building at ground level, then you can remove the casing, the burner, the hopper and the boiler controller. This will reduce the weight of the unit and make it easier to carry.

## NOTICE

### Contamination and corrosion

Make sure that the pellet boiler is located under a roof if it needs to be stored outside before it is transported/ brought into the building. It is also necessary to transport the boiler in a closed in truck or trailer. Boilers transported otherwise will lose their warranty.

### 7.2 Notes on bringing the unit into the building

Before bringing the unit into the building, check the dimensions of all doors to ensure that the boiler has sufficient clearance and can be set up properly.

#### Minimum door width - max. unit dimension

PE, PES	10, 12, 15, 20	27,5 inch
PE, PES	25, 32	29,75 inch
PES	36, 48, 56	31,2 inch

#### Boiler dimensions

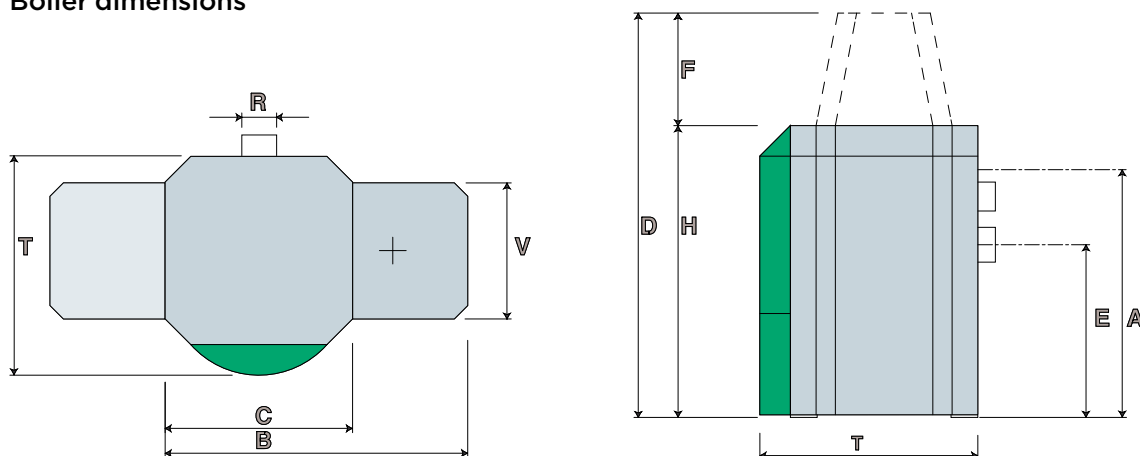

Boiler size		PE(S) 12	PE(S) 15	PE(S) 20	PE(S) 25	PE(S) 32	PE(S) 36	PE(S) 48	PE(S) 56
<b>B</b> – Overall width of pellet boiler	inch	44 1/2	44 1/2	44 1/2	46 3/4	46 3/4	51	51	51
<b>C</b> – Width of boiler casing	inch	27 1/2	27 1/2	27 1/2	29 3/4	29 3/4	34	34	34
<b>H</b> – Height of boiler casing	inch	43	43	43	51	51	61	61	61
<b>D</b> – Height of pellet suction system	inch	55	55	55	63	63	73	73	73
<b>F</b> – Height of suction filling unit	inch	12	12	12	12	12	12	12	12
<b>T</b> – Depth of boiler casing	inch	32	32	32	34 1/4	34 1/4	39	39	39
<b>V</b> – Depth of burner casing	inch	20	20	20	20	20	20	20	20
<b>E</b> – Flue gas tube connection height	inch	25 1/2	25 1/2	25 1/2	33 1/4	33 1/4	41	41	41
<b>A</b> – Height of supply/return	inch	35 3/4	35 3/4	35 3/4	43 3/4	43 3/4	52	52	52
<b>R</b> – Diameter of flue gas tube	inch	5 or 6	5 or 6	5 or 6	6	6	7	7	7

**Approximate boiler Weight**

Boiler size		PE(S) 12	PE(S) 15	PE(S) 20	PE(S) 25	PE(S) 32	PE(S) 36	PE(S) 48	PE(S) 56
Weight of boiler packaged on pallet with wooden frame	Lb	858	858	858	1003	1003	1430	1430	1430
Weight of boiler with casing, hopper and burner	Lb	533	542	551	696	705	1327	1336	1344
Weight of boiler without casing, hopper and burner	Lb	529	529	529	664	664	930	930	930

**Minimum clearances suggested for proper cleaning and maintenance**

**Note:**

To install the heating system properly and ensure economical operation, you need to make sure that minimum clearance dimensions indicated below are observed when setting up the boiler. **In addition, make sure that all code requirements at the installation location are complied with relating to the minimum clearances.**

<b>a</b>	Minimum clearance to the edge of removable top cover of the boiler. For flue pipe clearance, refer to applicable codes.	inch	18
<b>b</b>	Min. clearance of side of boiler	inch	3
<b>c</b>	Min. clearance of front of boiler	inch	28
<b>d</b>	Min. clearance to housing - burner side.	inch	12
<b>e</b>	Min. ceiling height And the distance from ceiling to top of boiler must be enough to remove all covers.	inch	73

**Note:**  
Place the boiler according to the minimum clearances to the flue pipe connection point as defined in NFPA 31, or if NFPA is not recognized, then the code pertinent to the installation location. Make sure that you also comply with local legal regulations. For clearances required for floor protection, see following page.

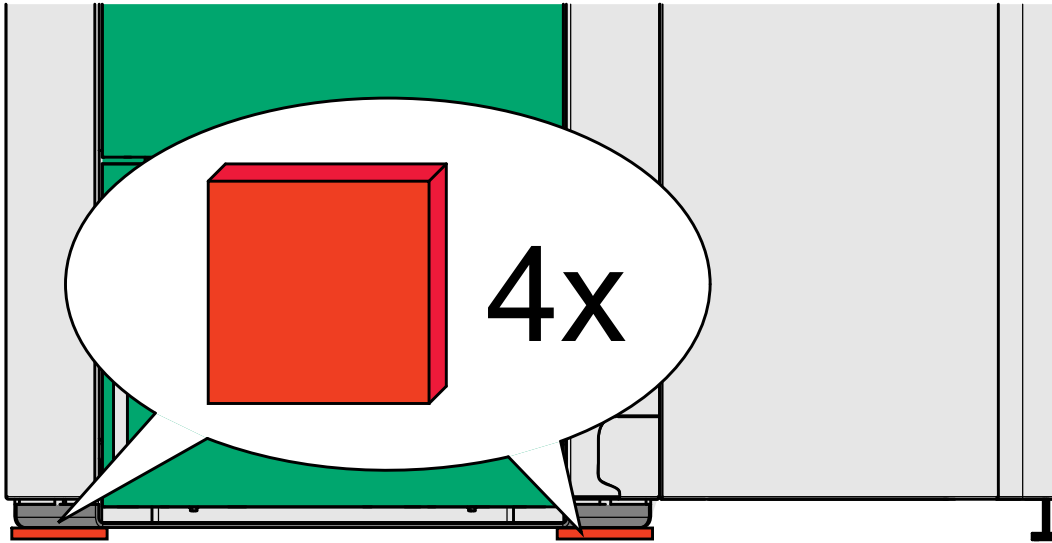
**Placement of rubber plates****NOTICE****Loss of warranty!**

The boiler must be placed on the supplied rubber plates.

Failure to do this may allow corrosion and will void the warranty of the boiler vessel.

## 7.3 Flooring

The boiler room floor must be flat and level and must be able to support boiler gross weight. The floor must comply with the requirements of NFPA 31.

Generally the boiler should be placed on non-combustible floors. However, a shielding material can be placed underneath the boiler and the chimney connector in the case of a combustible floor like shown on the following drawing.

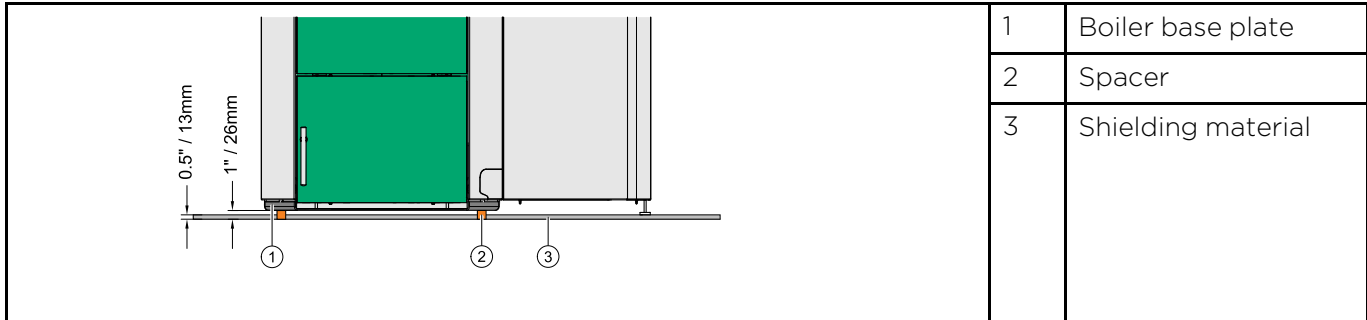

The spacer must be able to support the weight of the boiler and has to be non combustible. The shielding material must be equivalent to a 1/2in / 13mm micro board with a K-value of 0.49 (W/m K) (R-value of 1.02 Km<sup>2</sup>/W) or greater. For more information contact Maine Energy Systems.



### DANGER

**Risk of fire:**

The non-combustible flooring needs to extend out to the clearances shown on the chart below.

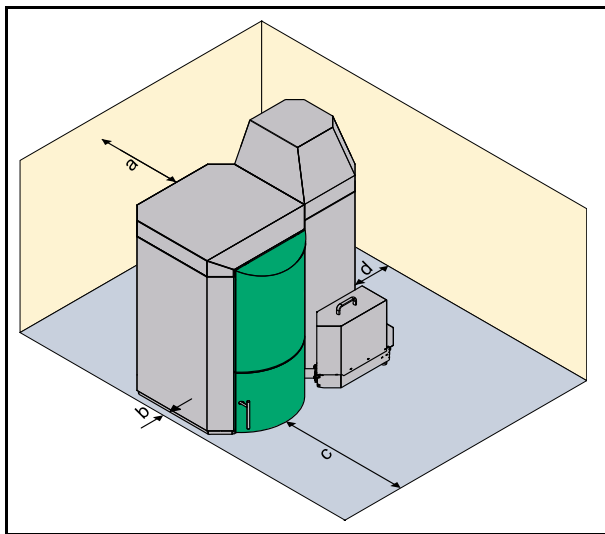

**Minimum clearances of shielding material required for floor protection**

Min. clearance of the shielding material from the boiler back - Note also the local restrictions in your area (a)	inch	17
Min. clearance of the shielding material from the boilers left side panel (b)	inch	8
Min. clearance of the shielding material from the boilers front panel (c)	inch	27
Min. clearance of the shielding material from the boilers right side panel (d)	inch	12

## 7.4 Casing parts

The boiler is protected by a casing on all sides. The casing parts prevent contact with hot, moving and live components. They give the pellet boilers a unique appearance.

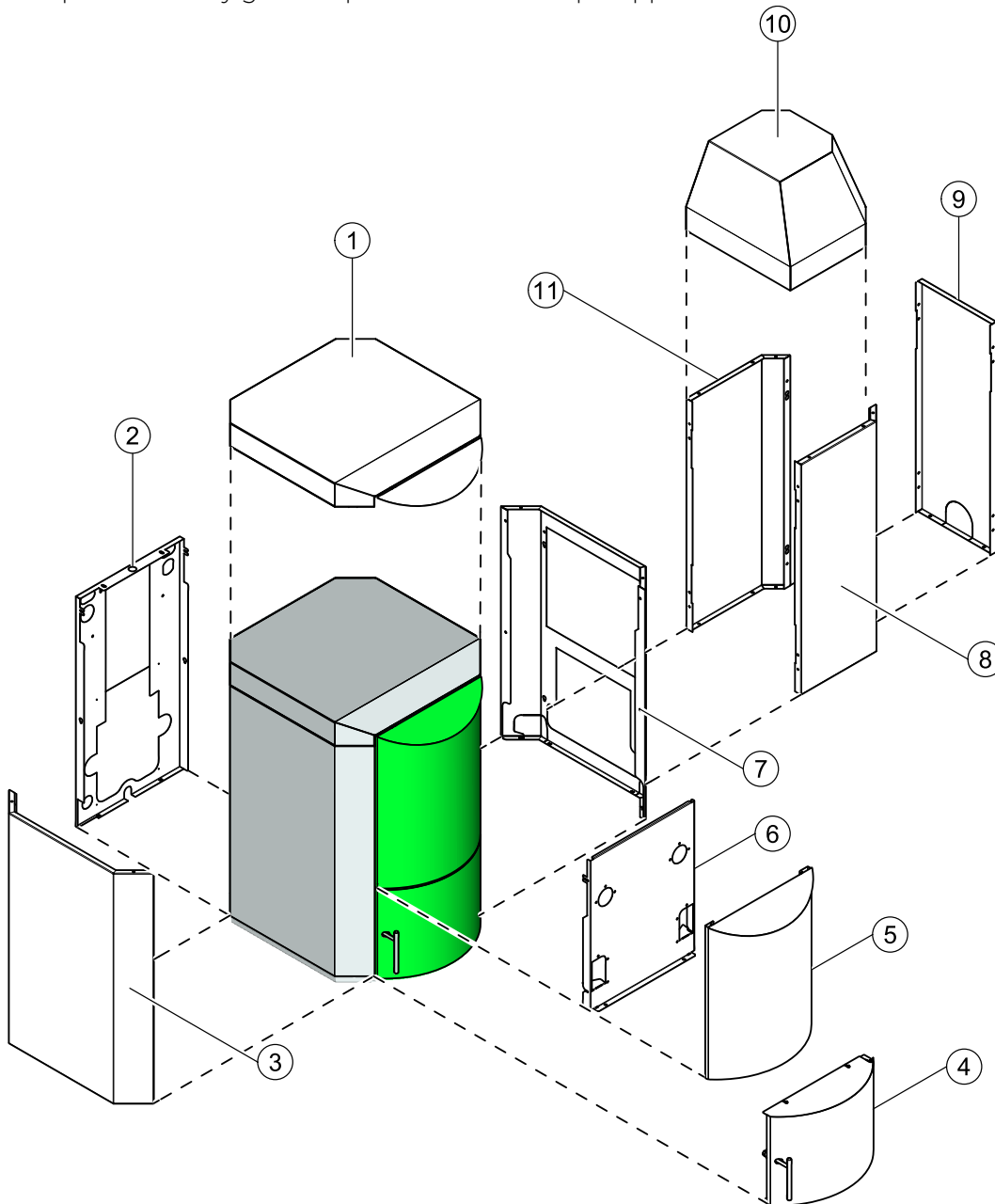

1	Boiler casing cover	7	Boiler side panel with opening
2	Boiler rear panel	8	Burner side panel (same as 11)
3	Boiler side panel without opening	9	Burner lug without opening
4	Boiler door panel (semi-circle)	10	Burner cover suction system
5	Boiler front panel (semi-circle)	11	Burner side panel (same as 8)
6	Boiler front panel (straight)		

## 7.5 Removing the casing, the hopper and the burner

Dismantle the pellet boiler as far as necessary if site conditions require, so that the unit can be brought safely into the building.

The complete dismantling of all components described here is divided into the following sections:

1. Dismantling the burner casing
2. Dismantling the hopper
3. Dismantling the burner
4. Dismantling the boiler door
5. Dismantling the boiler casing

### 7.5.1 Dismantling the burner casing

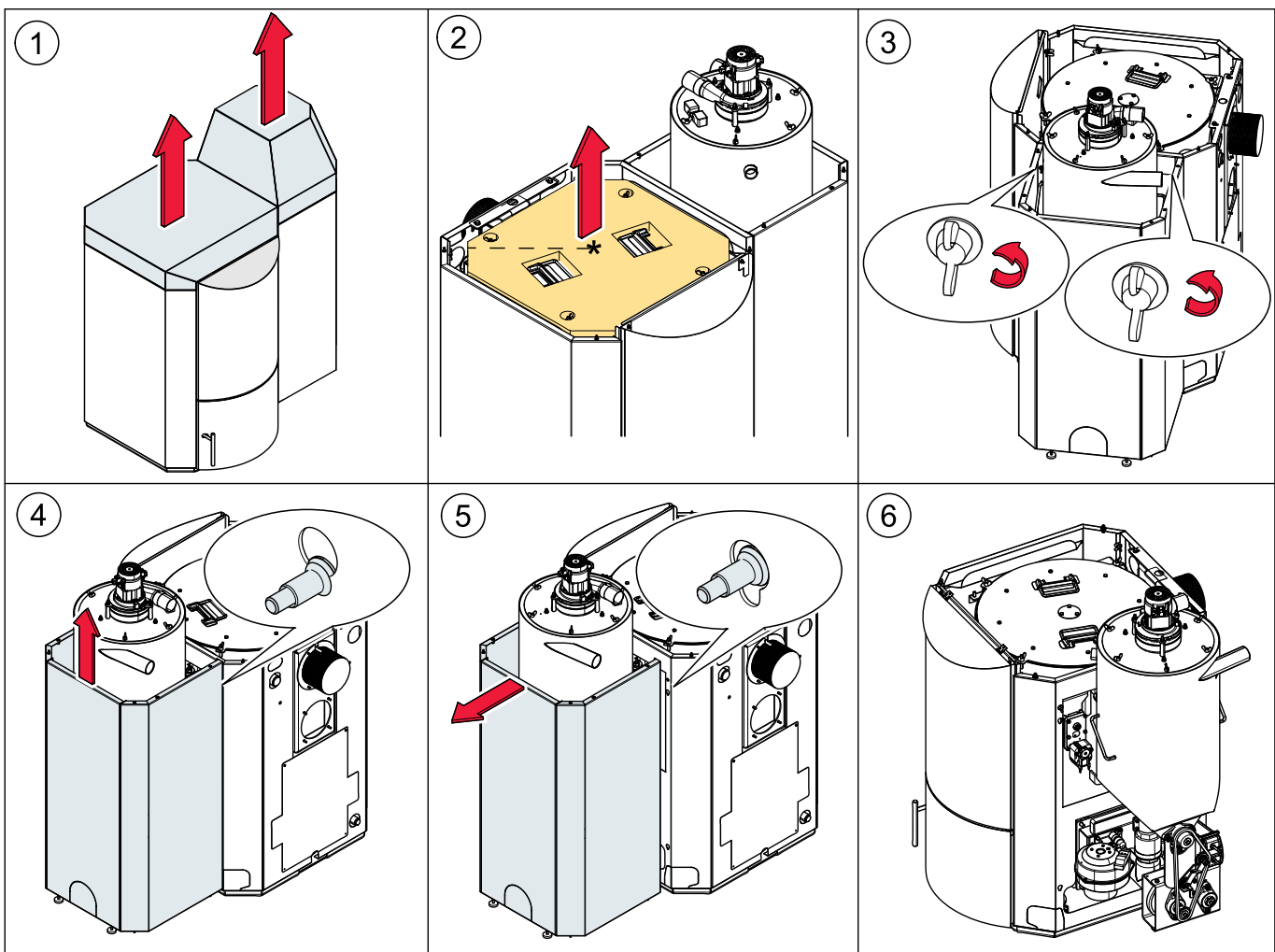

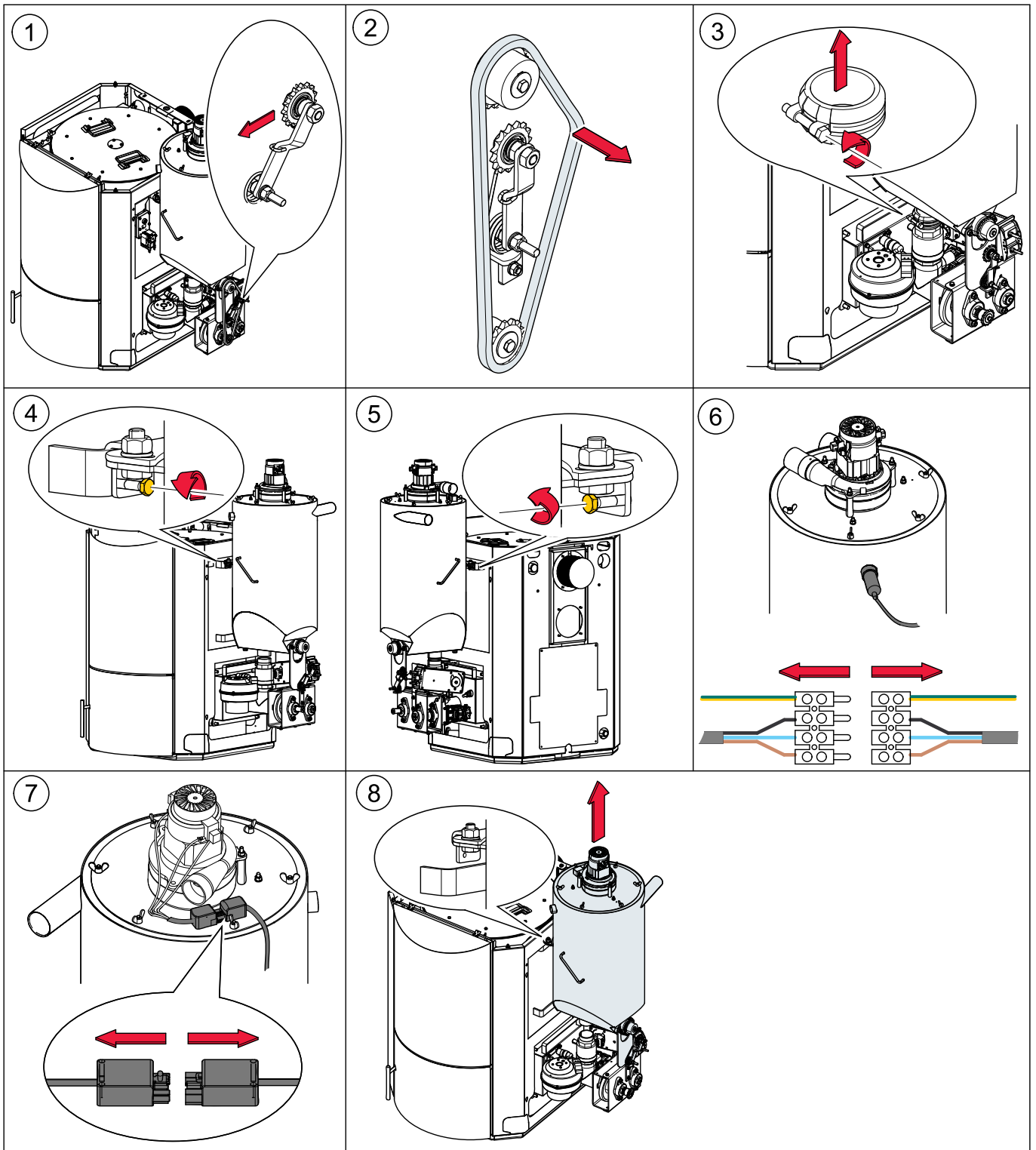

### 7.5.2 Dismantling the hopper



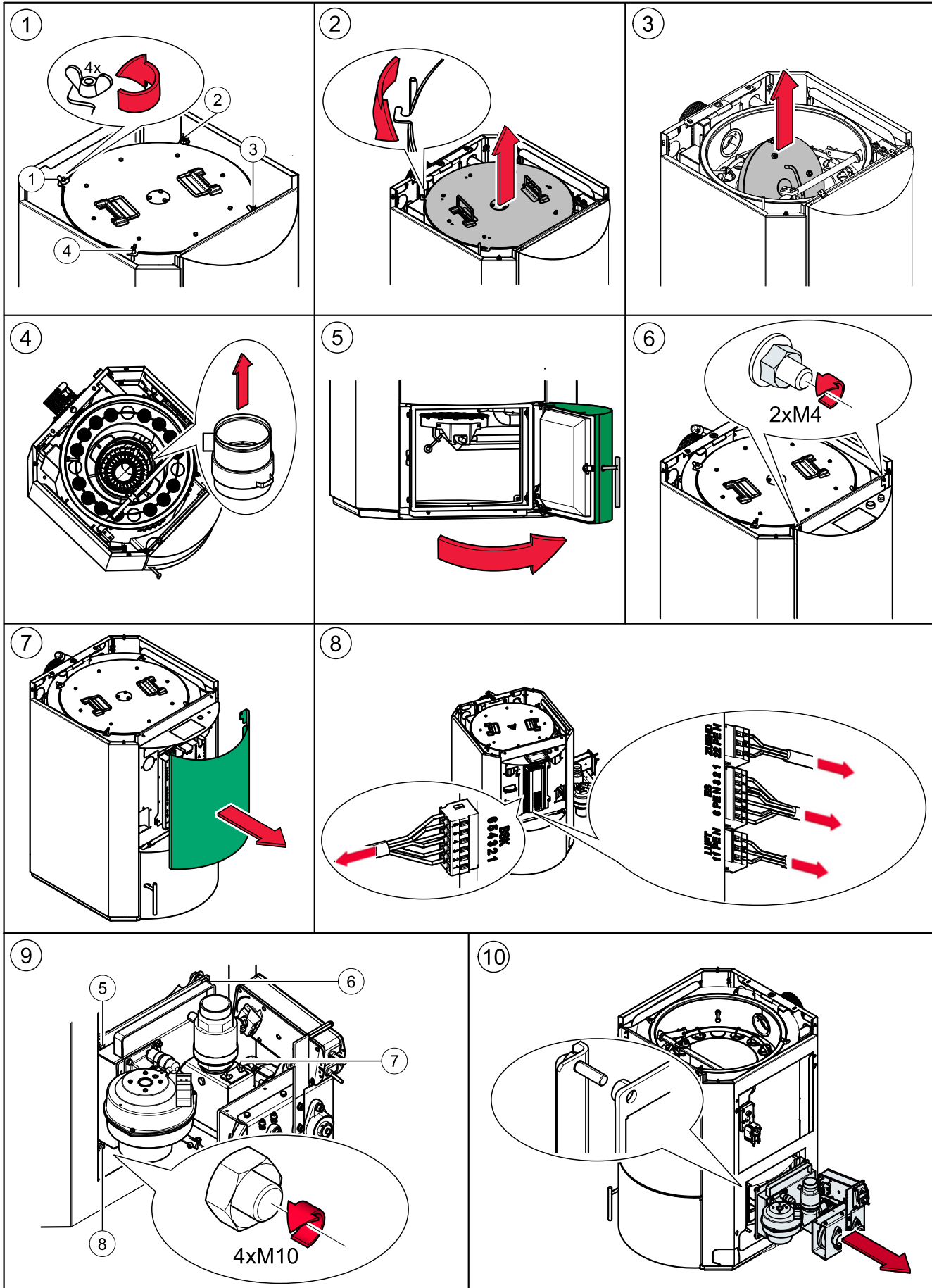

### 7.5.3 Dismantling the burner



 <h2 style="margin: 0;">DANGER</h2>
<p><b>Risk of electric shock</b>                  Behind the boiler front panel is the energized control unit. Disconnect main power before removing the front panel.</p>

<h2 style="margin: 0;">NOTICE</h2>
<p><b>Damage of property</b>                  Remove disconnect all of the electric cables that connect the burner assembly to the controller (at the controller end) before removing the burner.</p>

**Multi segmented burner plate**

There are 2 mounting variations:

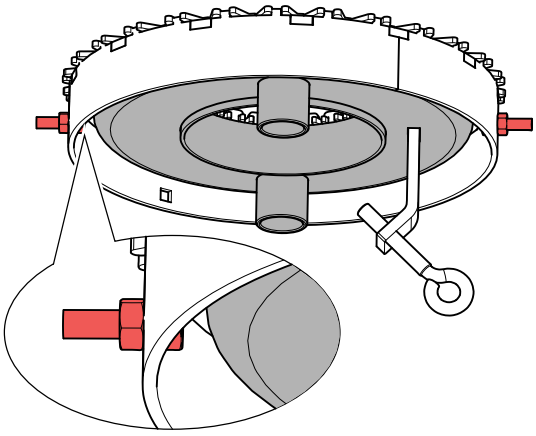
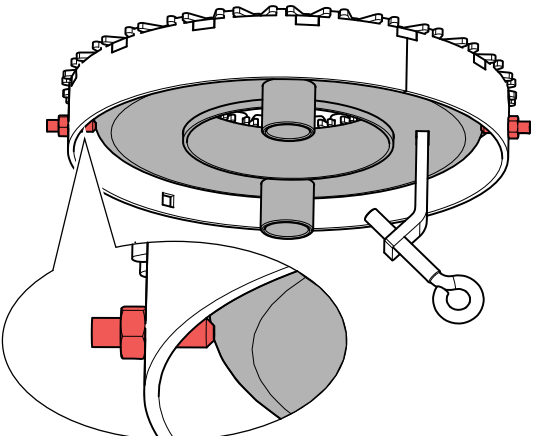
<b>With burner plate cleaning system: Bolts loosened</b>	<b>Without Burner plate cleaning system: Bolts tightened</b>
	
<h2 style="margin: 0;">NOTICE</h2>	<h2 style="margin: 0;">NOTICE</h2>
<p><b>Damage to property</b>                  The <b>safety screws</b> for rotating the Multi segmented burner plate must be loosened/removed when exchanging the Multi segmented burner plate.</p>	<p><b>Damage to property</b>                  The <b>safety screws</b> for rotating the Multi segmented burner plate may not be loosened/removed when mounting.</p>

### 7.5.4 Dismantling the boiler door

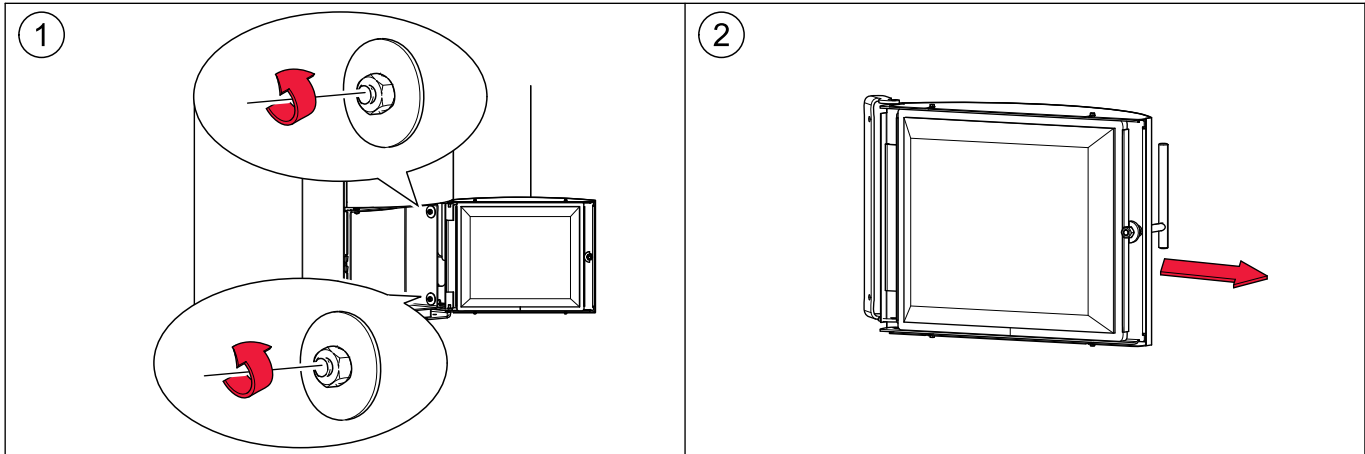

### 7.5.5 Dismantling the boiler casing

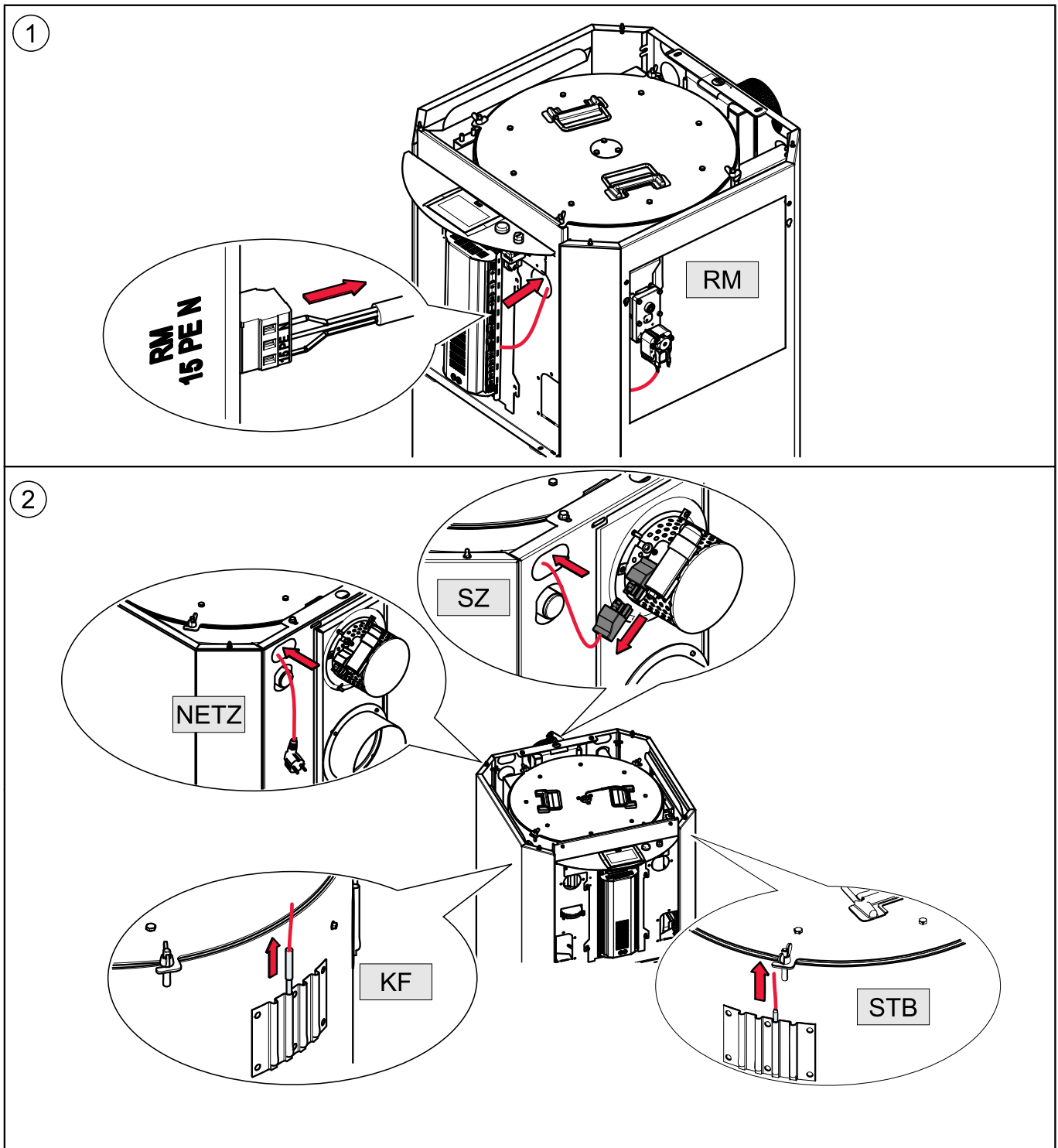

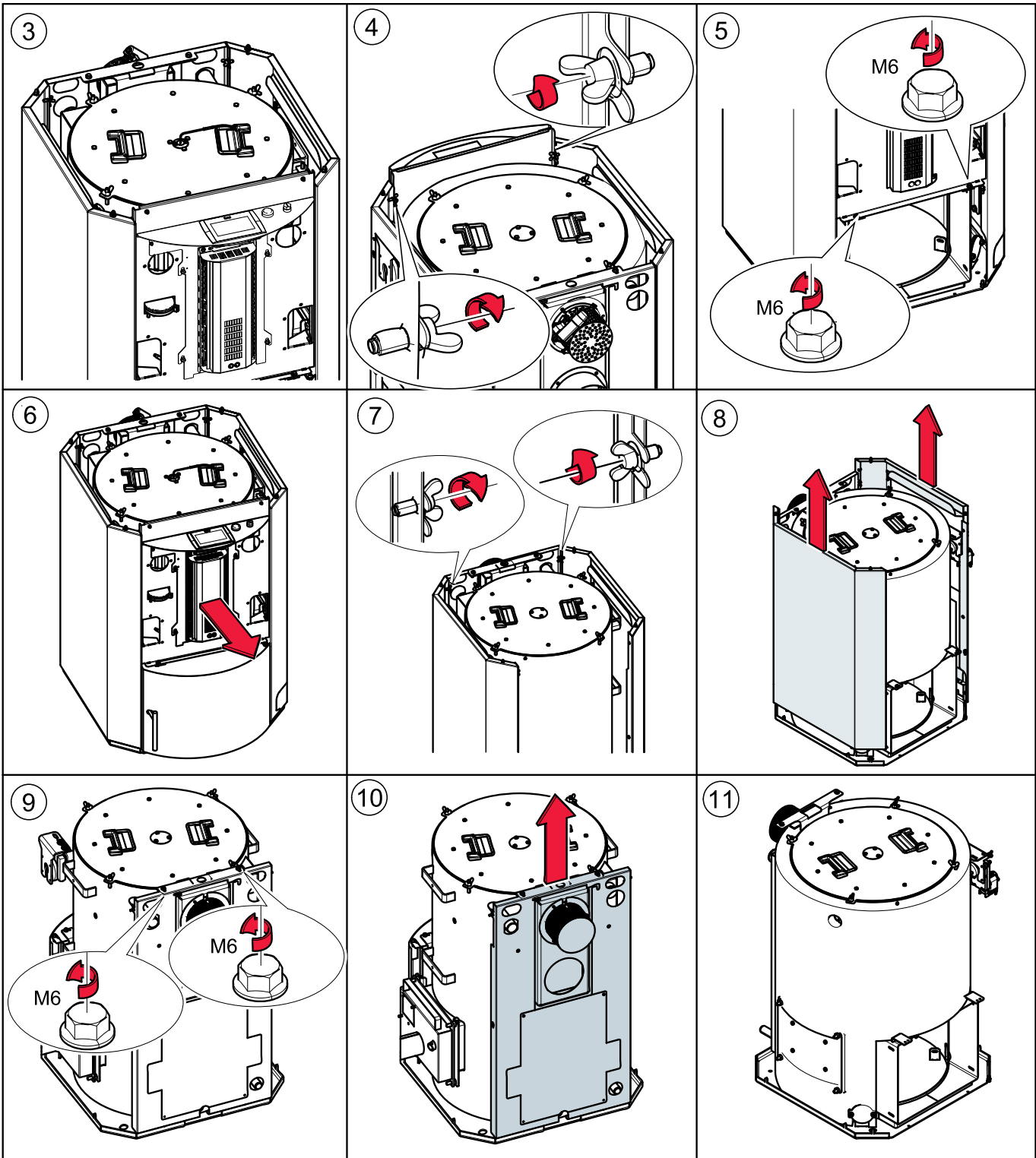

## 8 External de-ashing / automatic ash compaction system

We offer an automatic external de-ashing system.

1. Description of de-ashing system
2. How the de-ashing system works
3. Installing the de-ashing system
4. Emptying the de-ashing system

### 8.1 Description of de-ashing system

The de-ashing system compresses the ash and conveys it from the ash chamber into the ash box. The ash box enables the ash to be easily disposed off without creating dust.

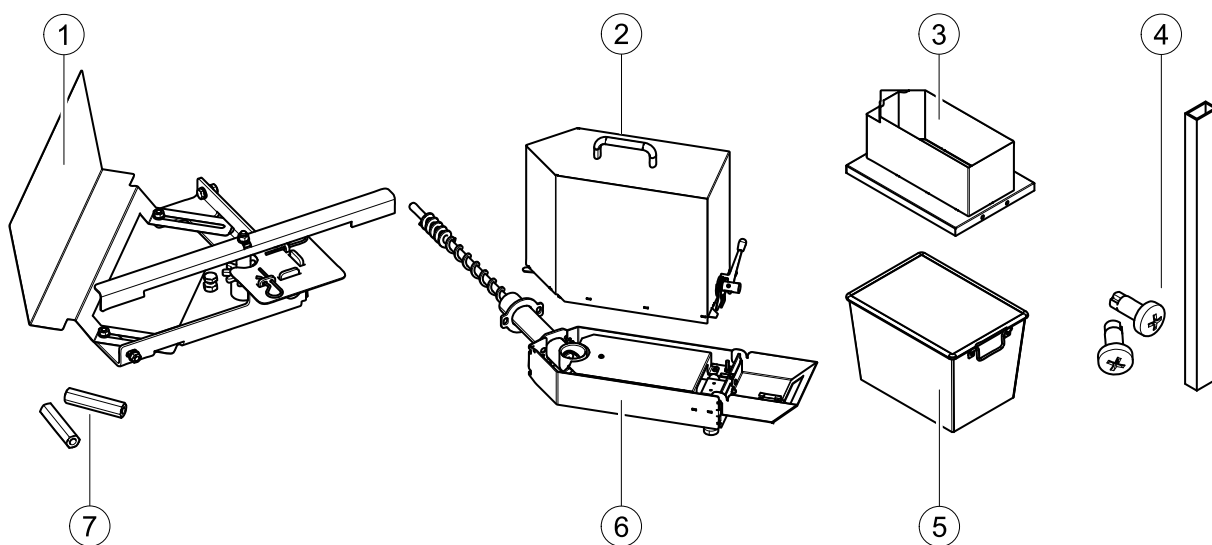

1	Turnstile with agitator, door plate and mounting bolts	5	Ash container
2	Ash box with single-hand lever	6	Sub-assembly with extractor auger and cable
3	Mounting frame	7	Extended nuts to secure the sub-assembly
4	Cable duct with mounting bolts	8	1 pack of bio-bags

**Note:**

All components for the de-ashing system are packaged in a separate box which is shipped together with the boiler. Open the box and check that all parts are available before starting work.

## 8.2 Installing the de-ashing system

We recommend installing the de-ashing system after the boiler has been brought in, but before the boiler casing is fitted. The de-ashing system has to be installed before the burner casing is assembled.

Installation of the de-ashing system is divided into the following steps:

1. Bringing in and installing the de-ashing system on the base plate
2. Installing the de-ashing auger, fitting the sub-assembly and mounting the door plate
3. Installing the burner side casing with cut-out and electrical connection
4. Assembling the pellet boiler and activating the ash box

### 8.2.1 Bringing in and installing de-ashing system on the base plate

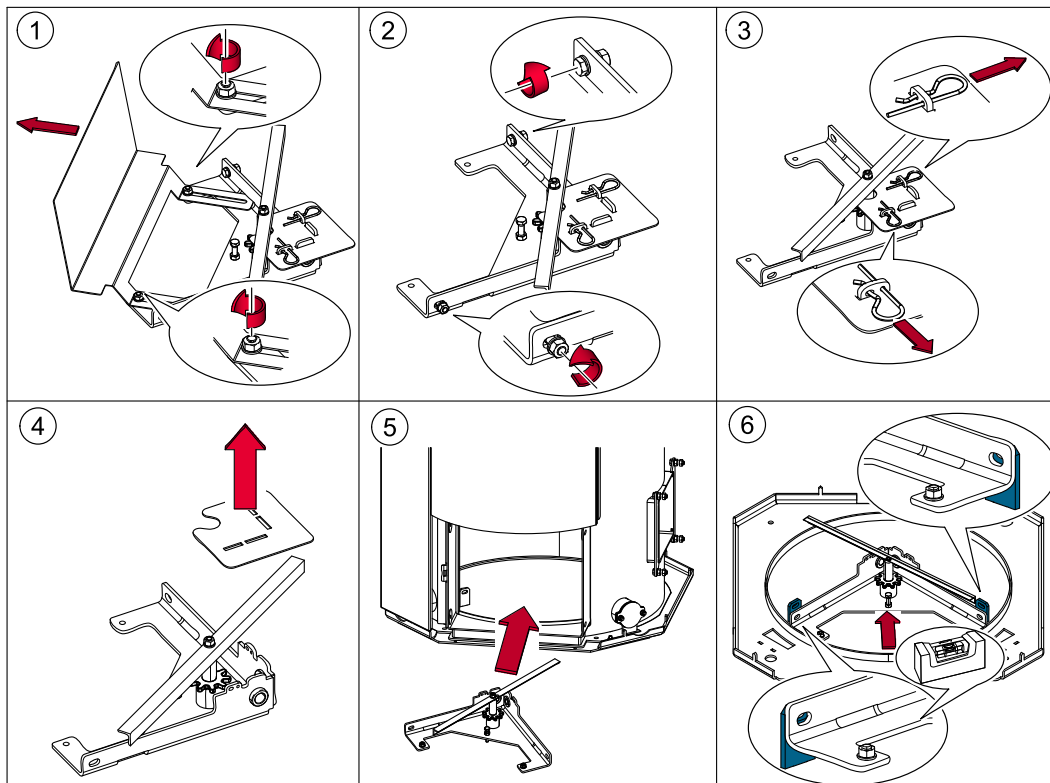

**Note:**

5: Replace the screw with the base in a horizontal position.

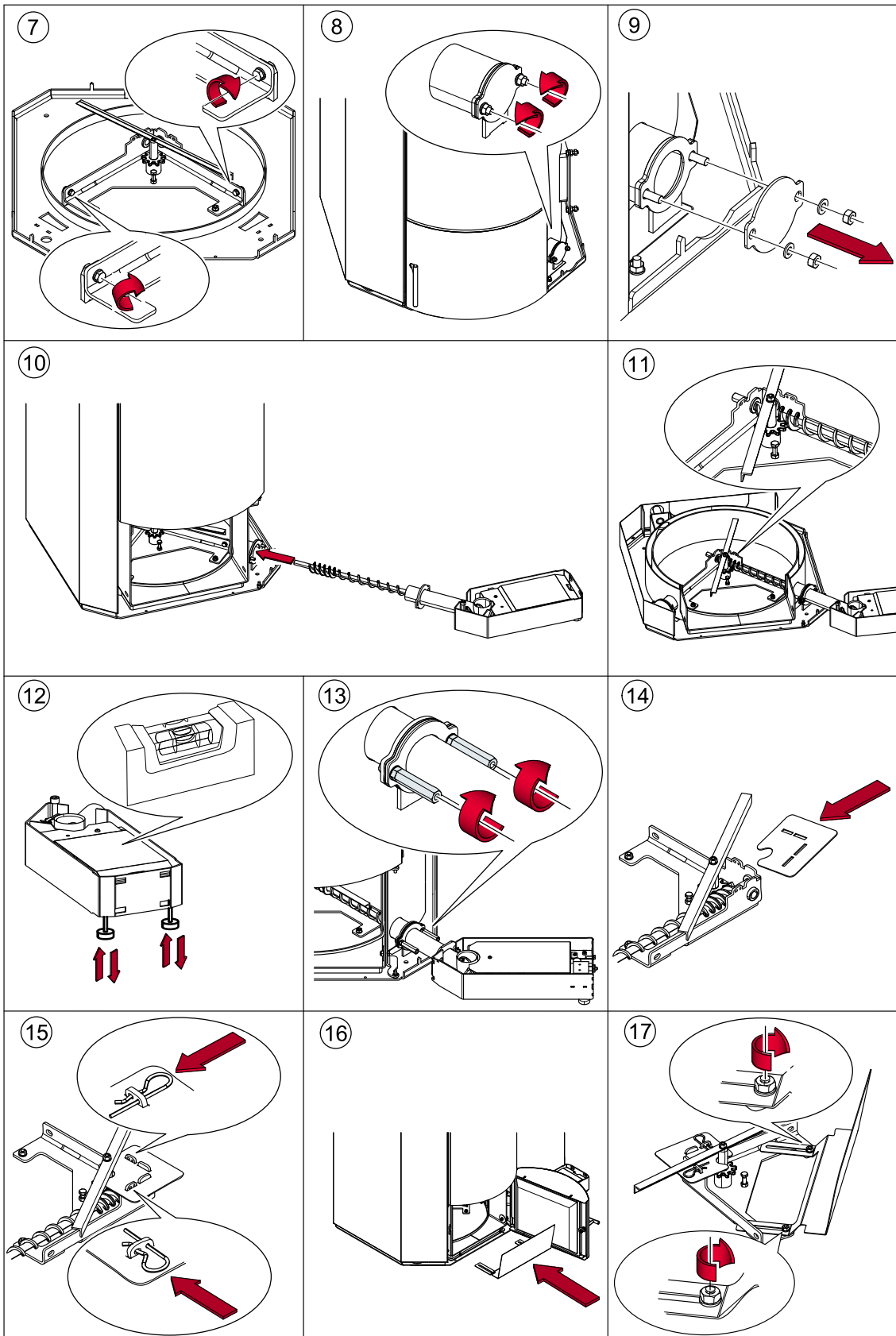
**8.2.2 Installing the ash auger, fitting the sub-assembly and mounting the door plate****Note:**

Do not tighten the screws firmly (picture 7). Tighten the screws firmly only after working step in picture 11. The ash auger engage with the gear must be so that the agitator moves freely.



### 8.2.3 Installing the burner side casing with cut-out and electrical connection

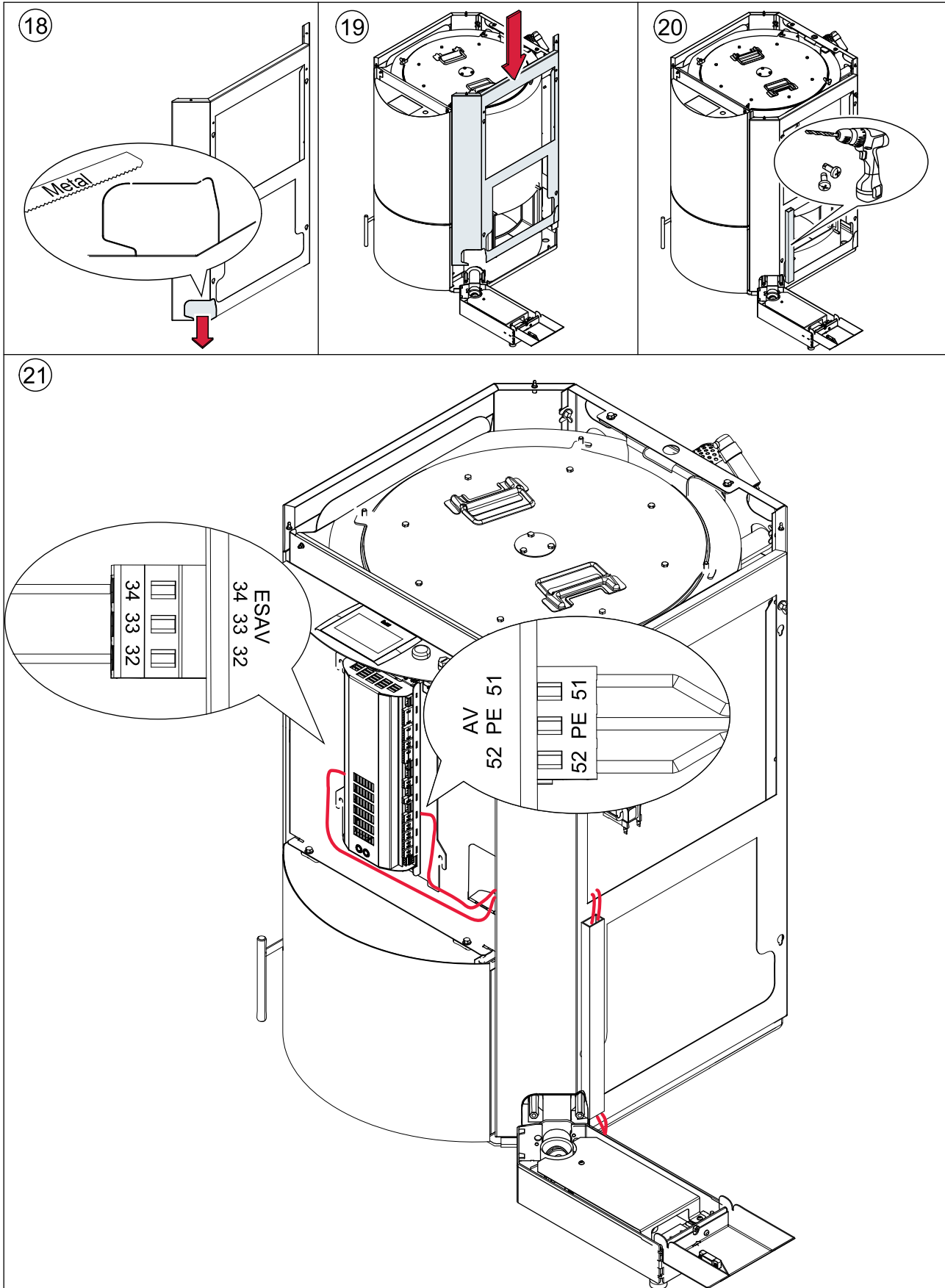

### 8.2.4 Assembling the pellet boiler and activating the ash box

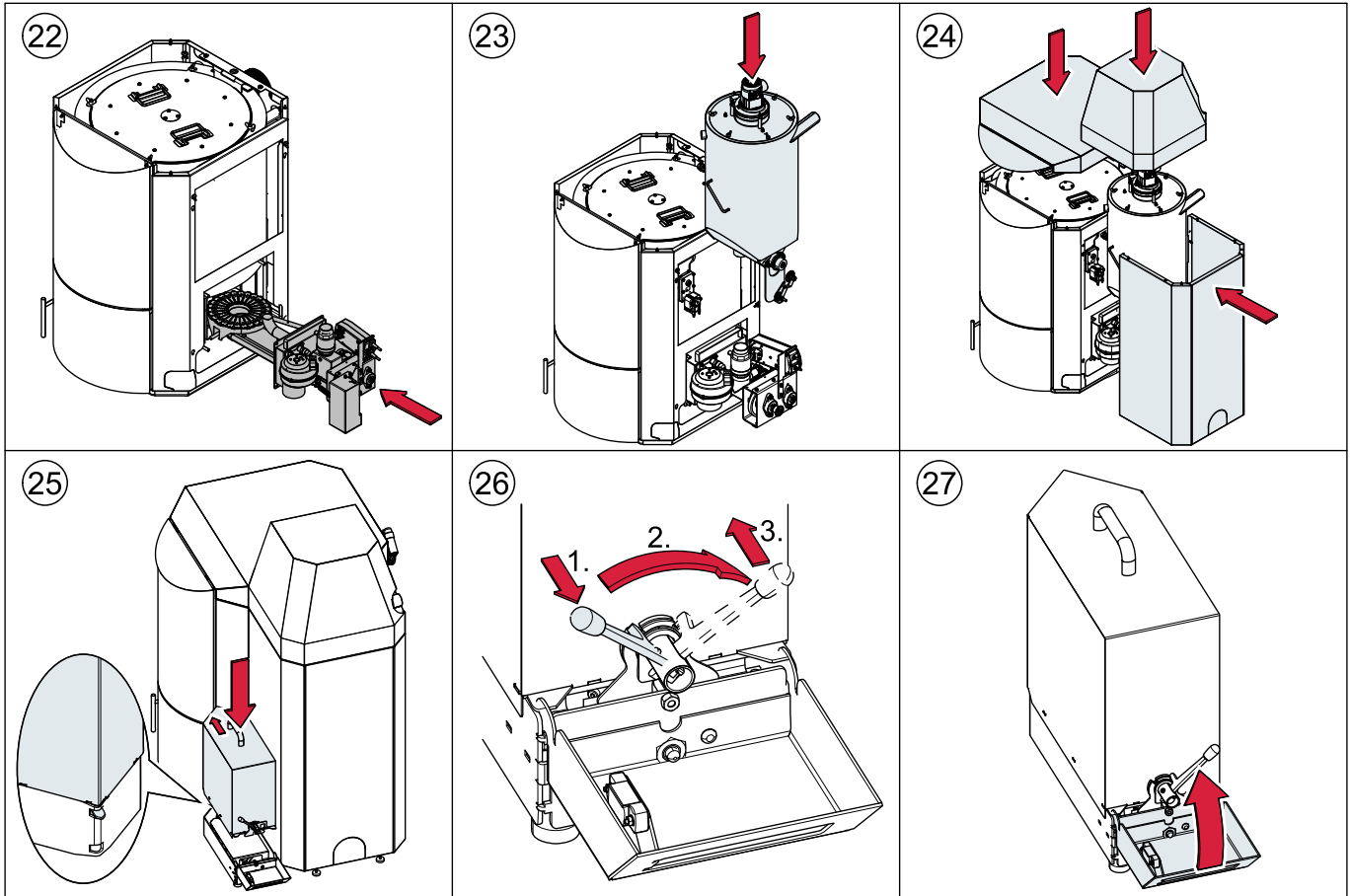

**Note:**

Refer to the section on bringing the pellet boiler into the boiler room for detailed instructions on assembling the hopper, burner and casing components.

#### Activating the ash box

1. Switch the boiler ON
2. In the menu Pellematic, after entering the code, you can activate the function **Ashbox**.
3. Set up the number from **0** to **1**
4. Ash box is now active

## 9 Connecting up the hydronics

The hydronic connections are located on the rear side of the boiler.



### DANGER

#### Risk of explosion

The boiler can only be connected and operated after the hydronic system is complete, with all safeties and purged of air.

### NOTICE

#### Water damage, damage to pellet boiler

The hydronic system can only be installed by an experienced heating professional. Check the entire installation for leaks before firing the boiler.

#### 1. Return water temperature control

The device to increase the return temperature is already integrated into the boiler. You do not need to make any adjustments to this.

#### 2. Hydronic schematics

If you have questions about piping a heating system, refer to our hydronic schematics when connecting the boiler.

Our hydronic schematics are available from your sales partner or from our website.

#### 3. Connections

The connections between the pellet boiler and the hydronic system must be disconnectable.

#### 4. Drain connection

When you install the pellet boiler, remove the plug from the drain connection (4) and fit a 1/2" diameter shut-off valve.

#### 5. Thermometer connection

Installing a thermometer at location (3) (submersion sleeve 3.94 in long) enables you to measure the temperature of the return water after the return water temperature control.

Whether this is installed or not, after setting up the pellet boiler you need to remove the cap and fit a 1/2" diameter closure plug at location (3).

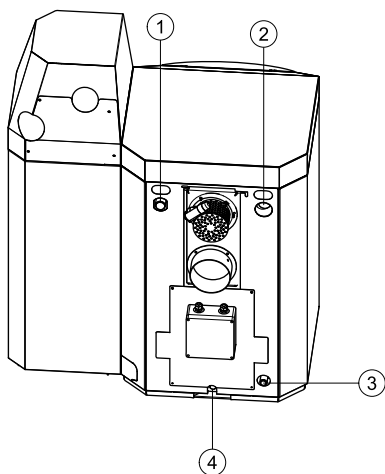

1	Flow out	3	Thermometer connection
2	Flow return	4	Drain connection

## 9.1 Hydronic connecting diagrams

**AutoPellet and existing gas or oil fired boiler**, modified "primary - secondary" allows heat to come from either source without external changes.

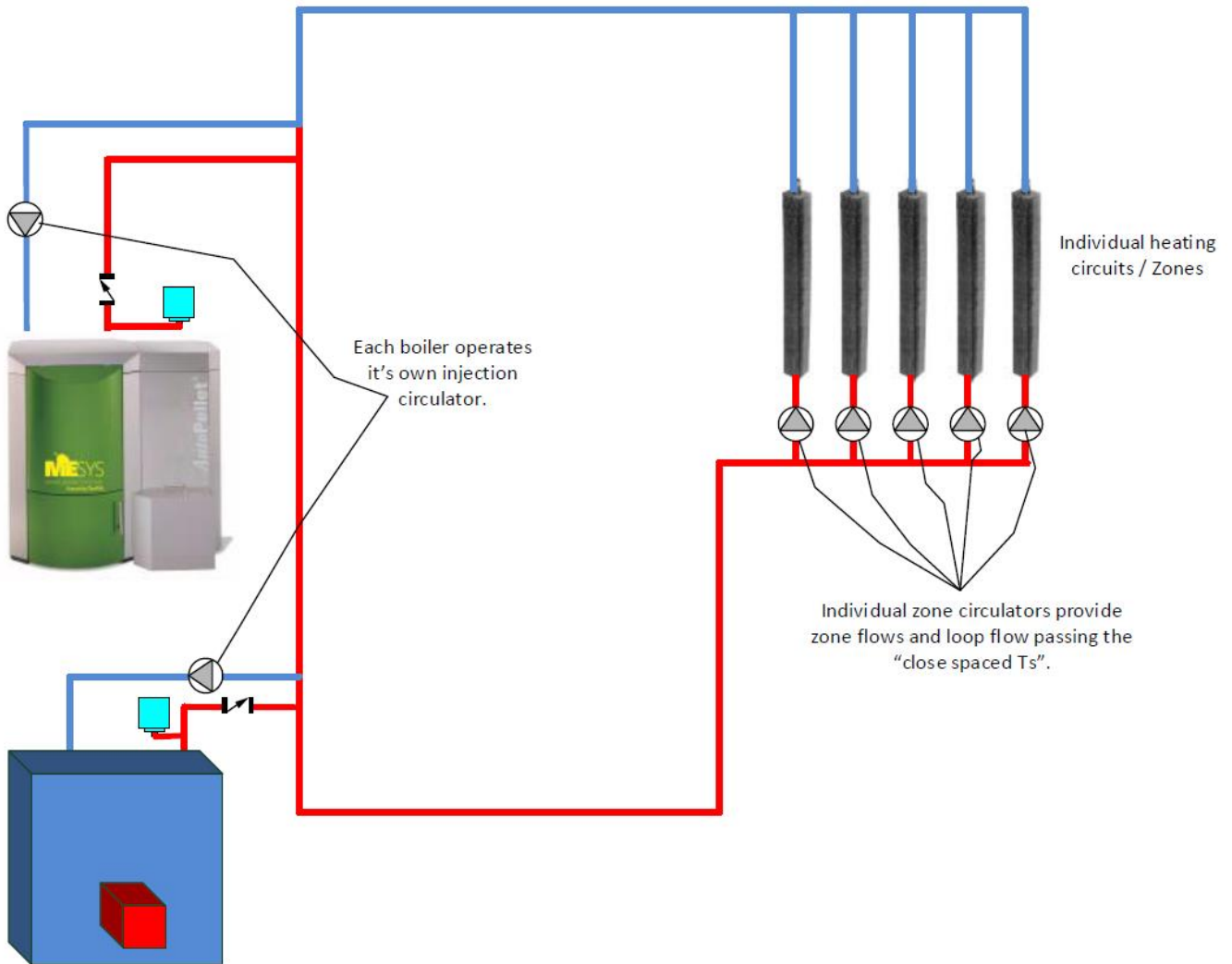

# 10 Connecting to the power supply

## 10.1 Terminal box

The terminal box serves as the connection point for the power supply, low water cut off, circulator pump, cold start contacts, bus connection, power vent, and outdoor sensor if used. There is also a low power 220 volt connection point.

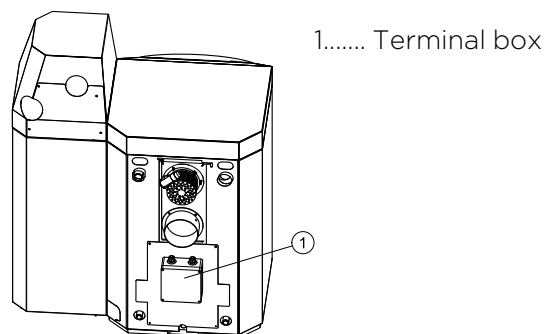

### 10.1.1 Wiring diagram - terminal box

The wiring diagrams for the terminal box provide detailed technical information for professionals and are packed within the terminal box along with other helpful schematics for interconnecting the boiler with circulator controls.



## DANGER

### Risk of electric shock

Only an authorised installer may connect the pellet boiler to the power supply.  
Always disconnect / de-energize the power supply before working on the boiler.

### General information for the electrician

- USA and Canada 208 to 240 VAC, single phase, 60 Hz, 15 amp dedicated circuit. To operate the boiler during prolonged power failures, the heating system, including controls and circulators, must be connected to a generator which produces clean, true 60 cycle power. Minimum suggested generator size, 2500W.
- **Lightening protection:** As there is no possible complete protection against lightening, we suggest installing a voltage spike suppression system for the building where the boiler is located or in the same panel as the boiler is powered from.
- **Electrical connection:**  
USA and Canada 208 to 240 VAC, single phase, 60 Hz, 15 amp dedicated circuit.

<b>Wiring Plan</b>	
<b>Terminal</b>	<b>Specification</b>
<b>1</b>	Hot wire L1 - Power supply 208 VAC
<b>2</b>	Hot wire L2 - Power supply 208 VAC
<b>3</b>	Neutral wire - Power supply 208 VAC
<b>≡</b>	Ground wire - Power supply
<b>4</b>	Hot wire - Boiler contact
<b>5</b>	Hot wire - Boiler contact
<b>6</b>	Hot wire - Domestic hot water pump
<b>7</b>	Neutral wire - Domestic hot water pump
<b>≡</b>	Ground wire - Domestic hot water pump
<b>8</b>	Hot wire - Boiler controlled pump
<b>9</b>	Neutral wire - Boiler controlled pump
<b>≡</b>	Ground wire - Boiler controlled pump
<b>10</b>	Hot wire - Power supply - Low water Cut-Off
<b>11</b>	Hot wire - Burner circuit - Low water Cut-Off
<b>12</b>	Neutral wire - Low water Cut-Off
<b>≡</b>	Ground wire - Low water Cut-Off
<b>13</b>	Hot wire L1 - Power supply
<b>14</b>	Hot wire L2 - Power supply
<b>≡</b>	Ground wire - Power supply
<b>15</b>	Hot wire - Power vent - Safety close contact
<b>16</b>	Hot wire - Power vent - Safety close contact
<b>≡</b>	Ground wire - Power vent
<b>17</b>	Hot wire - Power vent - Power supply 110VAC
<b>18</b>	Neutral wire - Power vent - Power supply 110VAC
<b>≡</b>	Ground wire - Power vent - Power supply 110VAC
<b>19</b>	Hot wire L1 - Delivery motor
<b>20</b>	Hot wire L2 - Delivery motor - Suction system
<b>21</b>	Hot wire L3 - Delivery motor - Suction system
<b>≡</b>	Ground wire - Delivery motor - Suction system
<b>22</b>	Neutral wire - Delivery motor - Suction system
<b>23</b>	Hot wire - Level detection system
<b>24</b>	Hot wire - Level detection system
<b>25</b>	Hot wire - Level detection system
<b>26</b>	Hot wire - Outdoor sensor
<b>27</b>	Hot wire - Outdoor sensor
<b>24V</b>	24V
<b>GND</b>	GND
<b>A</b>	A
<b>B</b>	B
<b>Shield</b>	Shield

WIRING DIAGRAM - Terminal box

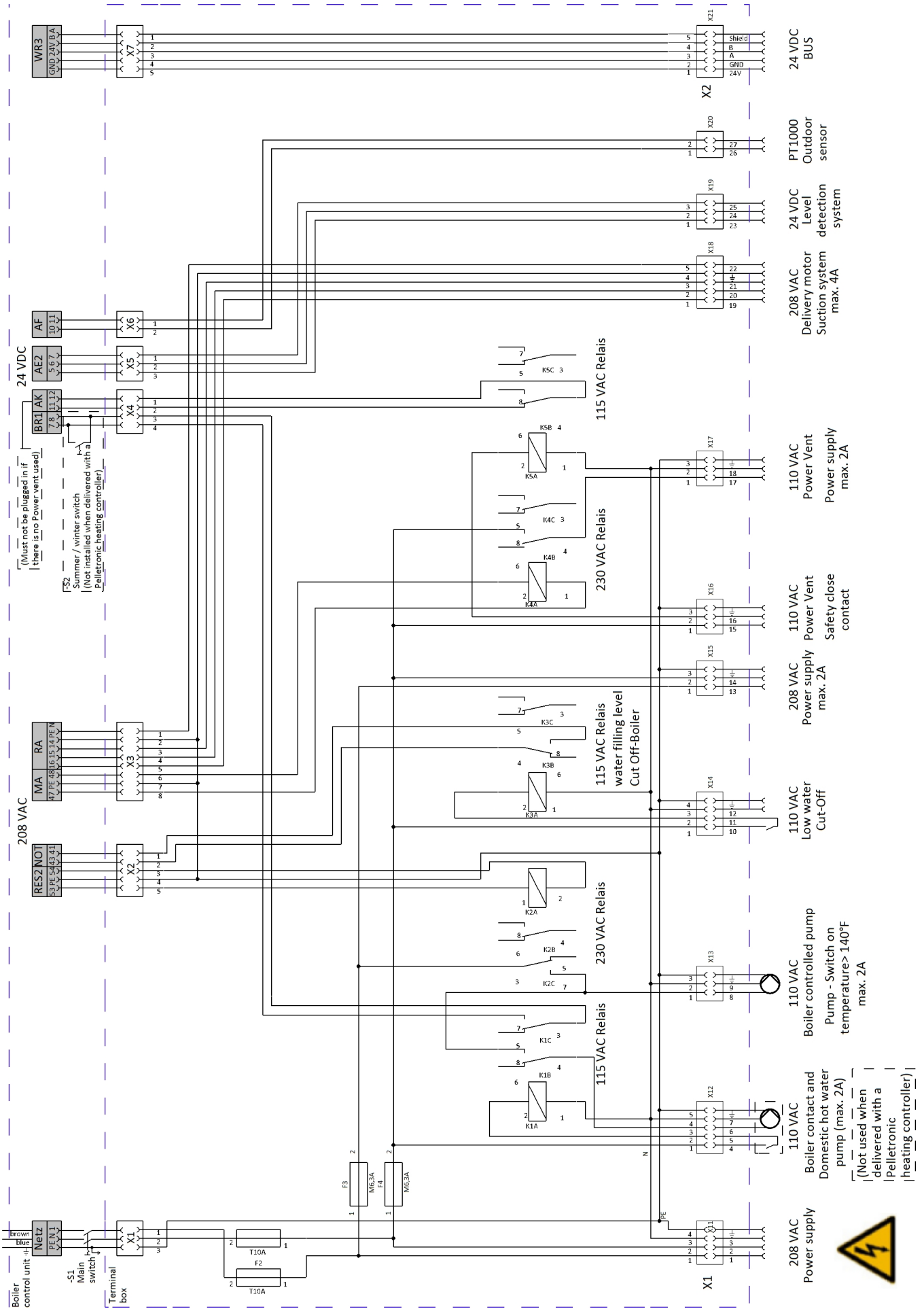

## 10.2 Plugs on the boiler control unit

The designation of the plugs must correspond with the labeling of plug-in positions.

Designation of plug-in position		Voltage	Name of sensors, motors and pumps
X1A	3 2 GND 1	24 Volt	Operating display
X1B	3 2 GND 1	24 Volt	Heating / zone controller
X2	5 4	24 Volt	Power supply display
R1	46 45	24 Volt	Not used
R2	44 43	24 Volt	Not used
AF	42 41	24 Volt	Not used
KF	8 9	24 Volt	Boiler sensor
UP	2 3 4	24 Volt	Negative draft measuring
AE2	5 6 7	24 Volt	Level detection system
AE1	10 9 8	24 Volt	Not used
FRT	12 13	24 Volt	Combustion chamber temperature sensor
RGF	14 15	24 Volt	Flue gas temperature sensor (optional)
PWM	16 17	24 Volt	PWM for speed controlled high-efficiency pump
Analog IN	18 19	24 Volt	Not used
BR1	7 8	24 Volt	Burner / "cold start" contact
AK	11 12	24 Volt	Existing boiler (optional)
ESAV	32 33 34	24 Volt	Ash box RPM feedback
DE 1	37 36 35	24 Volt	Not used
DE 2	40 39 38	24 Volt	Not used
KAPZW	26 25 24	24 Volt	Capacitive sensor - hopper
KAPRA	5 4 3	24 Volt	Capacitive sensor - burner
BSK	6 5 4 3 2 1	24 Volt	Ball valve / Flame return gate
X21	PE L N	230 Volt	Power supply
VAK	50 PE 49	230 Volt	Vacuum turbine
ZUEND	N PE 22	230 Volt	Ignition
AV	52 PE 51	230 Volt	Motor ashbox
RES 2	53 PE 54	230 Volt	Not used
MA	48 PE 47	230 Volt	Magnetic valve (Cleaning nozzle, heat exchanger)
RM	15 PE N	230 Volt	Motor for boiler flame tube cleaning device
SM	19 20	230 Volt	Relay fault signal (optional)
SZ	17 PE N	230 Volt	Flue gas fan
UW	13 PE N	230 Volt	Boiler controlled pump
STB	17 PE 19	230 Volt	Safety temperature / Over-temp sensor
NOT	43 41	230 Volt	Connection to low water protection / Emergency stop heating
RA1	N PE 14 15 16	230 Volt	Fuel transport system
RES1	50 PE 49	230 Volt	Motor hopper - PES 36-56 only



ZW	N PE 26 25 24	230 Volt	Vibration motor
ES	1 2 3 N PE 6	230 Volt	Burner motor
LUFT	N PE 11	230 Volt	Burner fan

## 10.3 Cable routing

Reroute cables after dismantling the casing or other system components.



### DANGER

#### Risk of electric shock

Switch off the system before performing work on the boiler.

Note the following points to ensure the cables are routed securely:

Cables must not be routed:

- over moving parts
- over hot parts
- over sharp edges

Cables must be:

- routed in the cable ducts provided
- through cable leadthroughs
- tied together
- secured with cable ties at the points provided
- Power cables must be routed in the right-hand duct and sensor cables must be routed in the left-hand duct.



### DANGER

#### Risk of electric shock

Check cables for damage..  
Replace any cables that are damaged.

### NOTICE

#### Damage to the boiler controller

Before fitting the casing components, make sure that all cables are connected to the correct points on the controller! Failure to do so can lead to damage to the controller, and such damage is not covered by warranty!

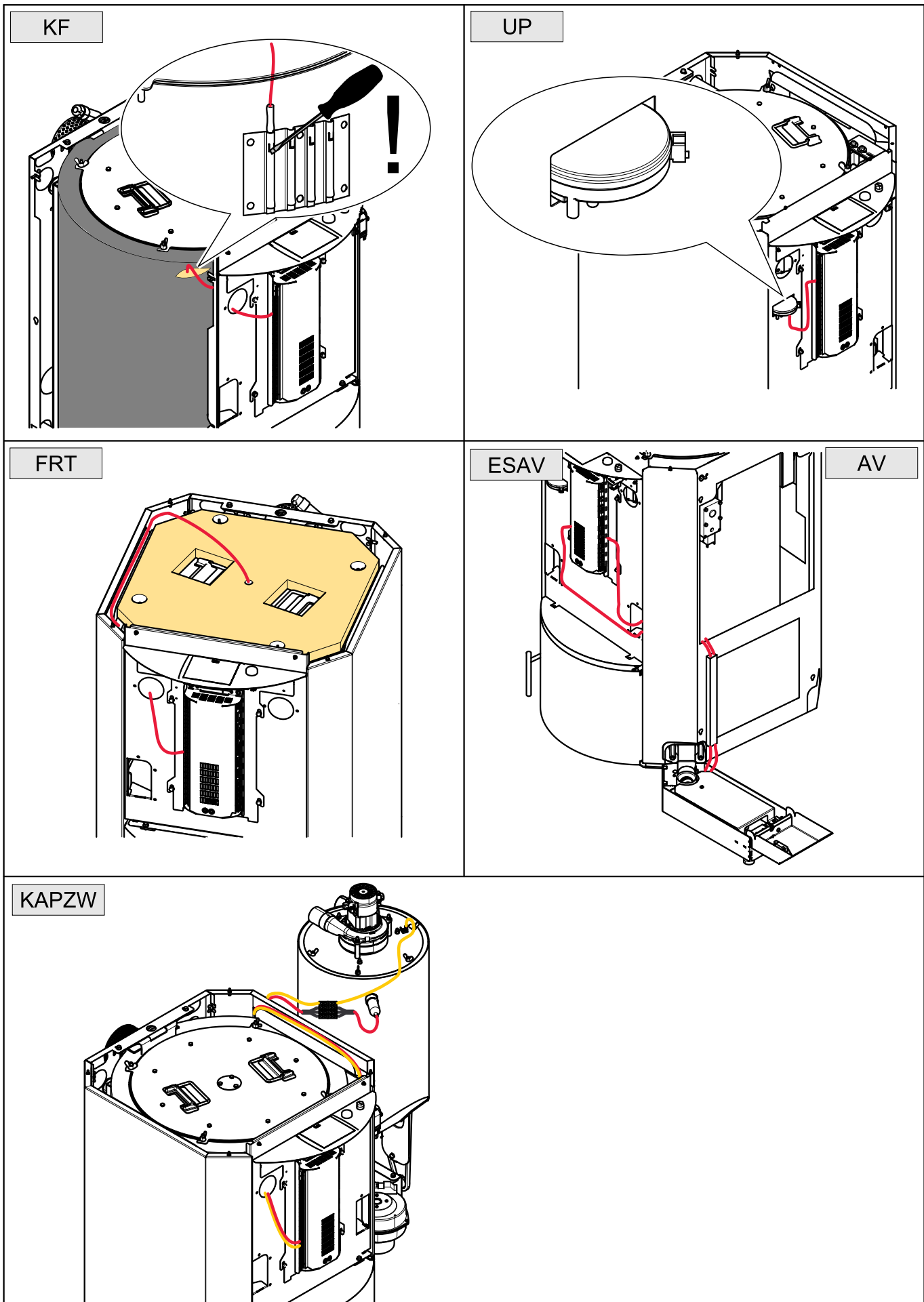

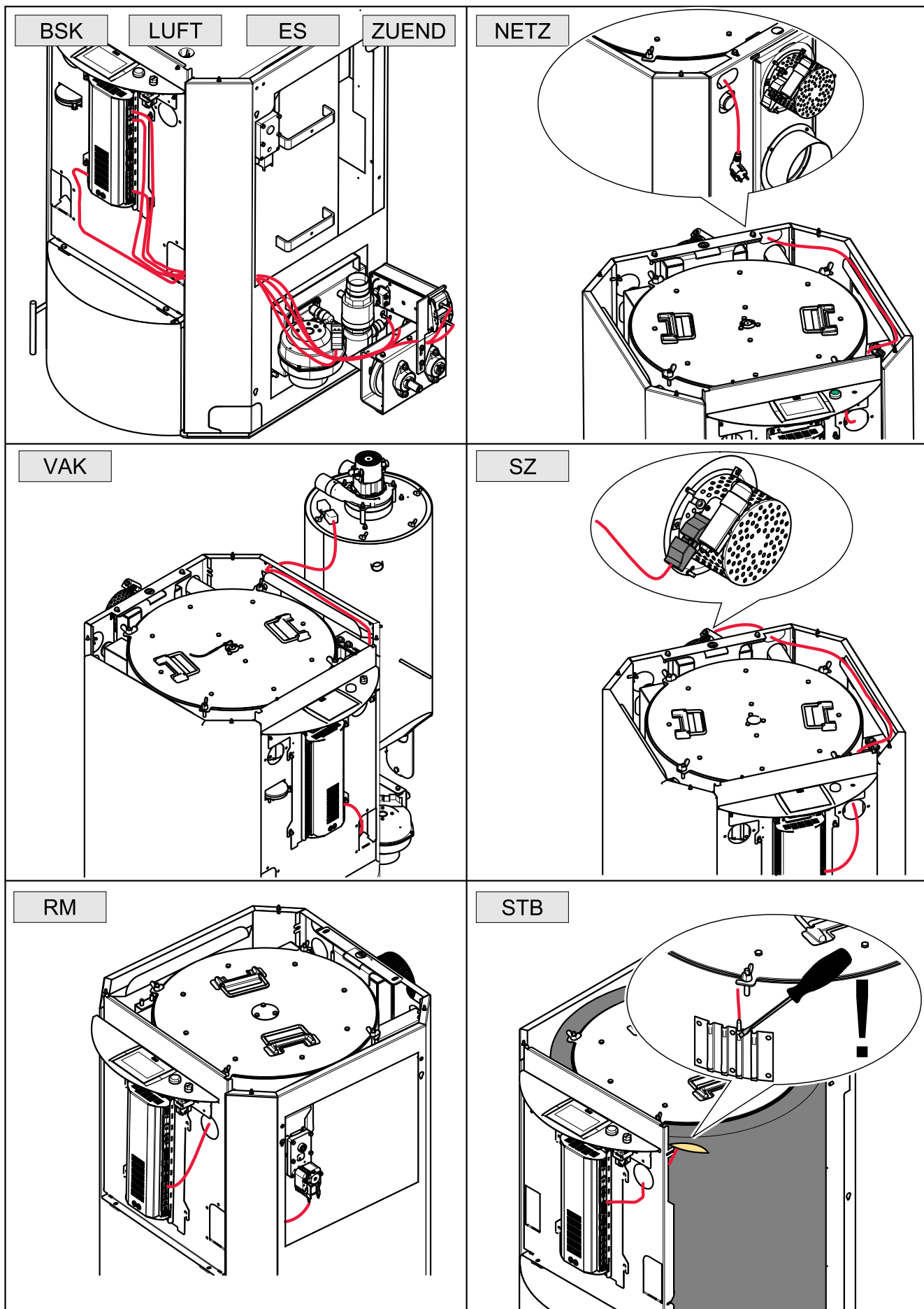

## 10.4 Wiring diagrams

The wiring diagrams for the boiler control unit provide detailed technical information for electricians.

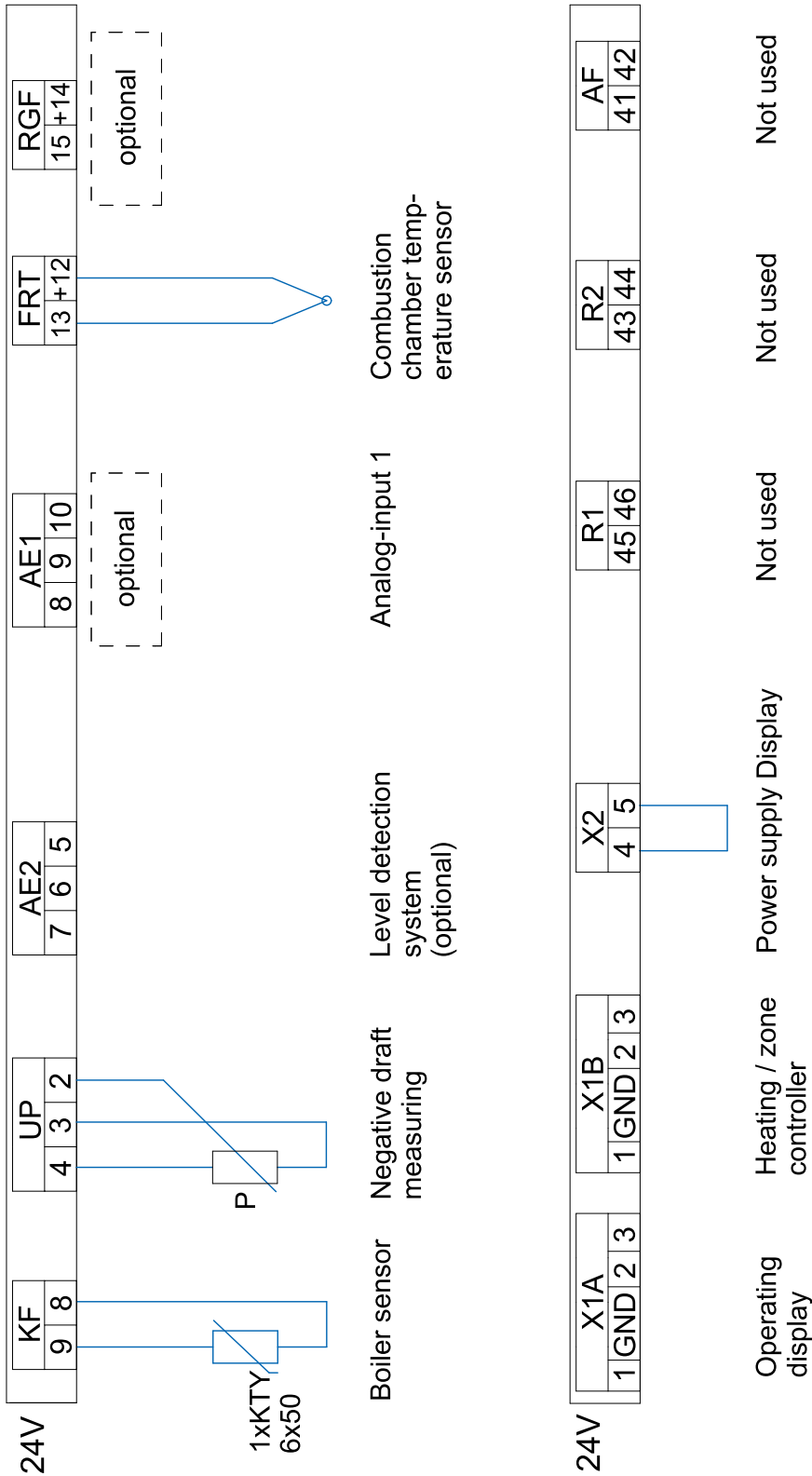

DANGER

**Electric shock**  
 Only an authorised installer may connect the pellet boiler to the power supply.  
 Isolate the entire heating system from the power supply before starting work on the pellet boiler.

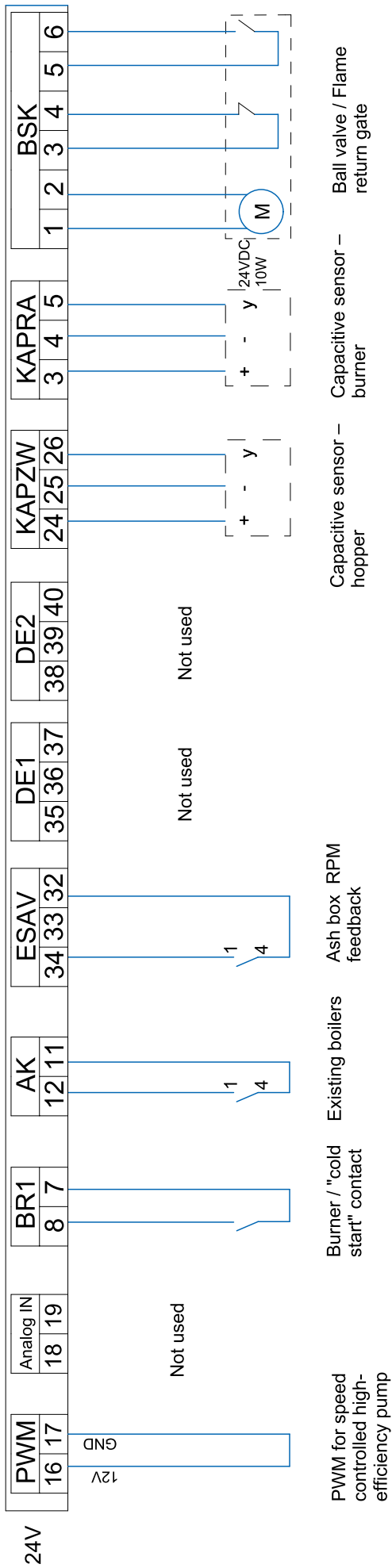

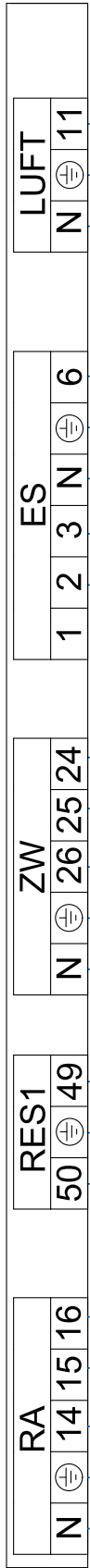

115V-  
240V



230VAC  
max. 4A

Fuel transport  
system

230VAC  
max. 2A

Motor hopper –  
PES 36–56  
only

230VAC  
max. 2A

Vibration motor  
(optional)

230VAC  
50W  
max. 2A

Burner motor-  
Auger system  
with vibration motor

230VAC  
85W  
max. 2A

Burner fan

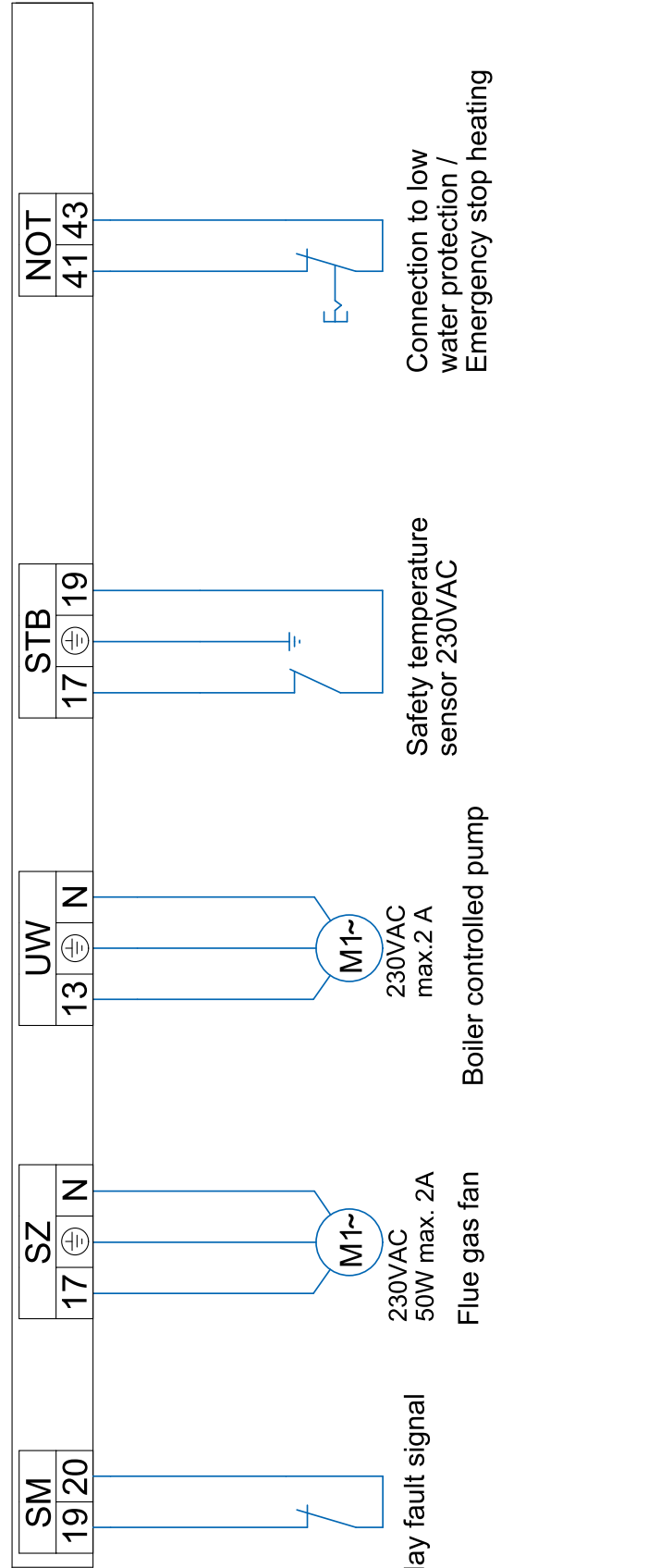

Relay fault signal

230VAC  
50W max. 2A

Flue gas fan

230VAC  
max. 2 A

Boiler controlled pump

Safety temperature  
sensor 230VAC

Connection to low  
water protection /  
Emergency stop heating

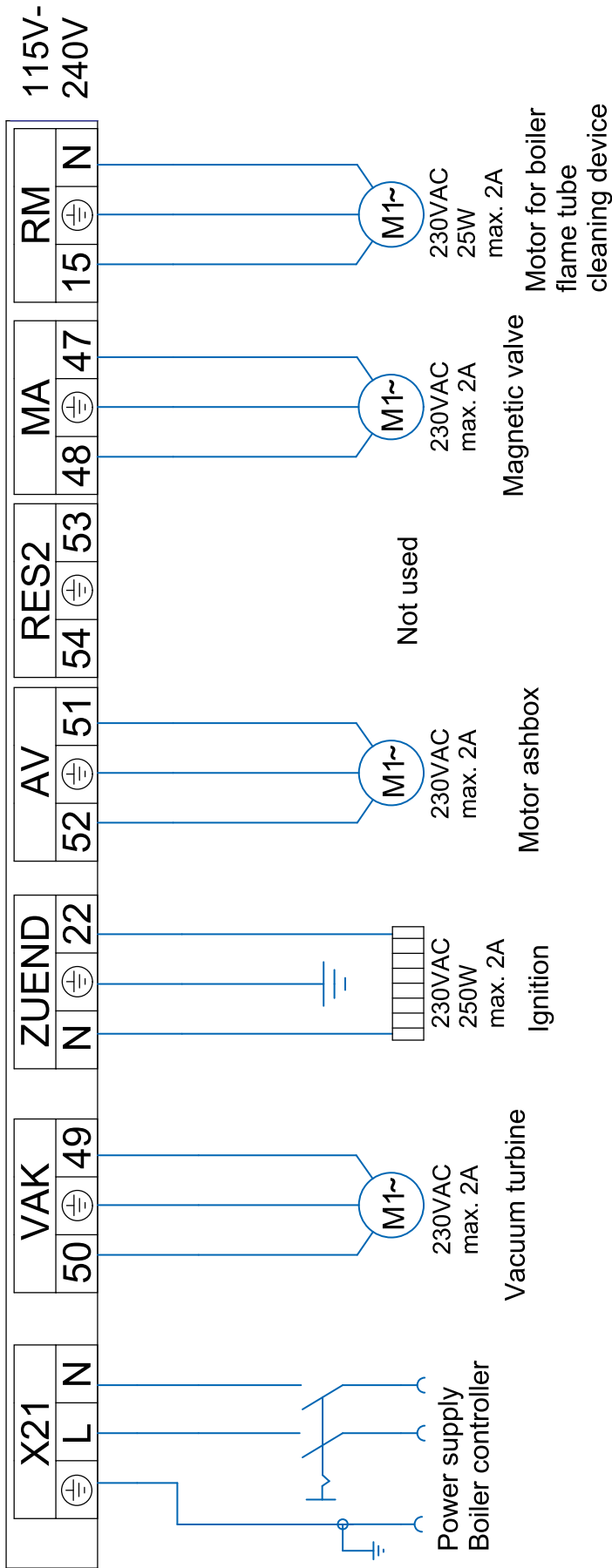



## 10.5 Fuses - boiler controller

The control unit is protected against short circuits by fuses which are in the control panel (under the front boiler panel). There are also fuses in the terminal box at the rear of the boiler. At the rear panel, there are 4 fuses. Two 6.3 amp for outputs there, and two 10 amp also for the main controller.

### NOTICE

#### Damage of property

Should it become necessary to replace a fuse, it is critically important to replace the fuse only with a fuse having the same exact ratings.

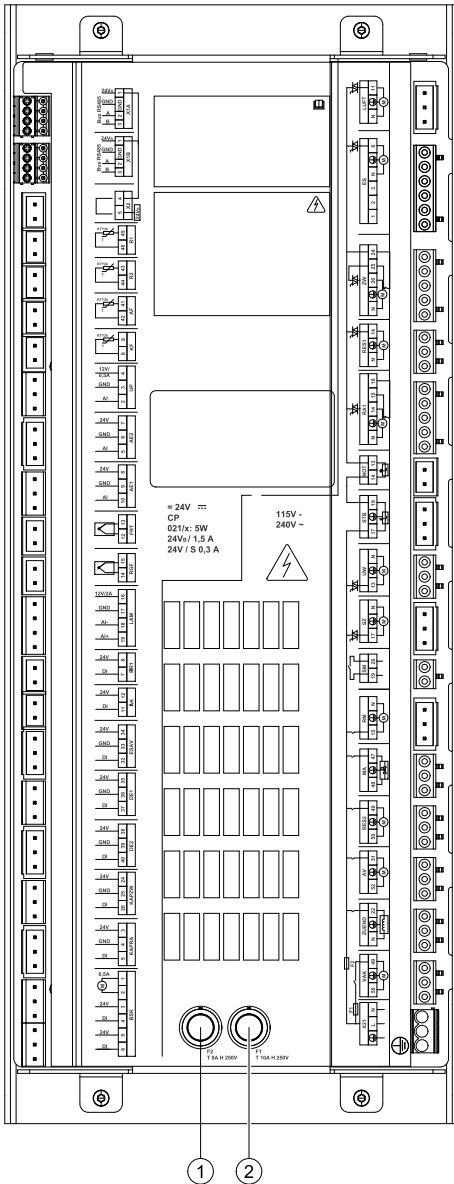

1	F1: Fuse T8A
2	F2: Fuse T10A

## 10.6 Operating the AutoPellet

The operation of the system is described in the **manual for the End User**.

# 11 Starting up for the first time

After bringing in the boiler, connecting up the hydronics and power supply, the unit can be started up for the first time.

## NOTICE

### Air tight property of combustion chamber

To ensure correct combustion and overall operation, all fittings to the combustion chamber must be correctly assembled to be completely air-tight.

### Note:

The boiler may only be commissioned (first start-up) by an authorized installer.

Before starting up the pellet boiler, the following settings must be made in the sequence specified below:

1. Adjust power rating
2. Settings in the boiler control unit
3. Output test - test all motors
4. Settings in heating controller (if installed)
5. Start the pellet boiler

Use the checklist enclosed to document the start-up procedure.

## NOTICE

### Property damage

The allowed temperature of the boiler controller is 40 to 122°F.

## 11.1 Adjusting power rating

On Autopellet boilers the effective heat exchanger area can be changed within a finite range. This involves opening or closing the heat exchanger tubes. The output power of the boiler is adjusted with this change in conjunction with a parameter change within the controller. If the condition as shipped is different from the power rating required, then the service technician must adjust the power rating, including the correct setting of the heat exchanger area, before starting up for the first time.

### 11.1.1 Installing the turbulators and closure plugs

The heat exchanger in the pellet boiler has between 12 and 36 heat exchanger tubes, depending on the size of the boiler. Springs are installed inside the heat exchanger tubes to clean the tubes as well as act as turbulators.

#### Increasing the boiler power rating

1. Remove the closure plugs from the ends of the heat exchanger tubes.
2. Insert the turbulators supplied into the heat exchanger tubes.
3. Hook the turbulators onto the ring of the cleaning system.

#### Reducing the boiler power rating

1. Unhook the turbulators from the ring of the cleaning system.
2. Remove the cleaning springs/turbulators from the heat exchanger tubes.
3. Close off the heat exchanger tubes using the closure plugs supplied.

**Number of cleaning springs (turbulators) to be removed/installed:**

Final boiler power setting	No. of springs	Full power setting of boiler	No. of springs	
41,000 BTU/h	10	68,300 BTU/h	16	Remove 6 turbulators
51,000 BTU/h	12	68,300 BTU/h	16	Remove 4 turbulators
68,300 BTU/h	16	68,300 BTU/h	16	No adjustment required
85,300 BTU/h	16	109,500 BTU/h	20	Remove 4 turbulators
109,500 BTU/h	20	109,500 BTU/h	20	No adjustment required
123,000 BTU/h	30	191,000 BTU/h	36	Remove 6 turbulators
164,000 BTU/h	32	191,000 BTU/h	36	Remove 2 turbulators
191,000 BTU/h	36	191,000 BTU/h	36	No adjustment required

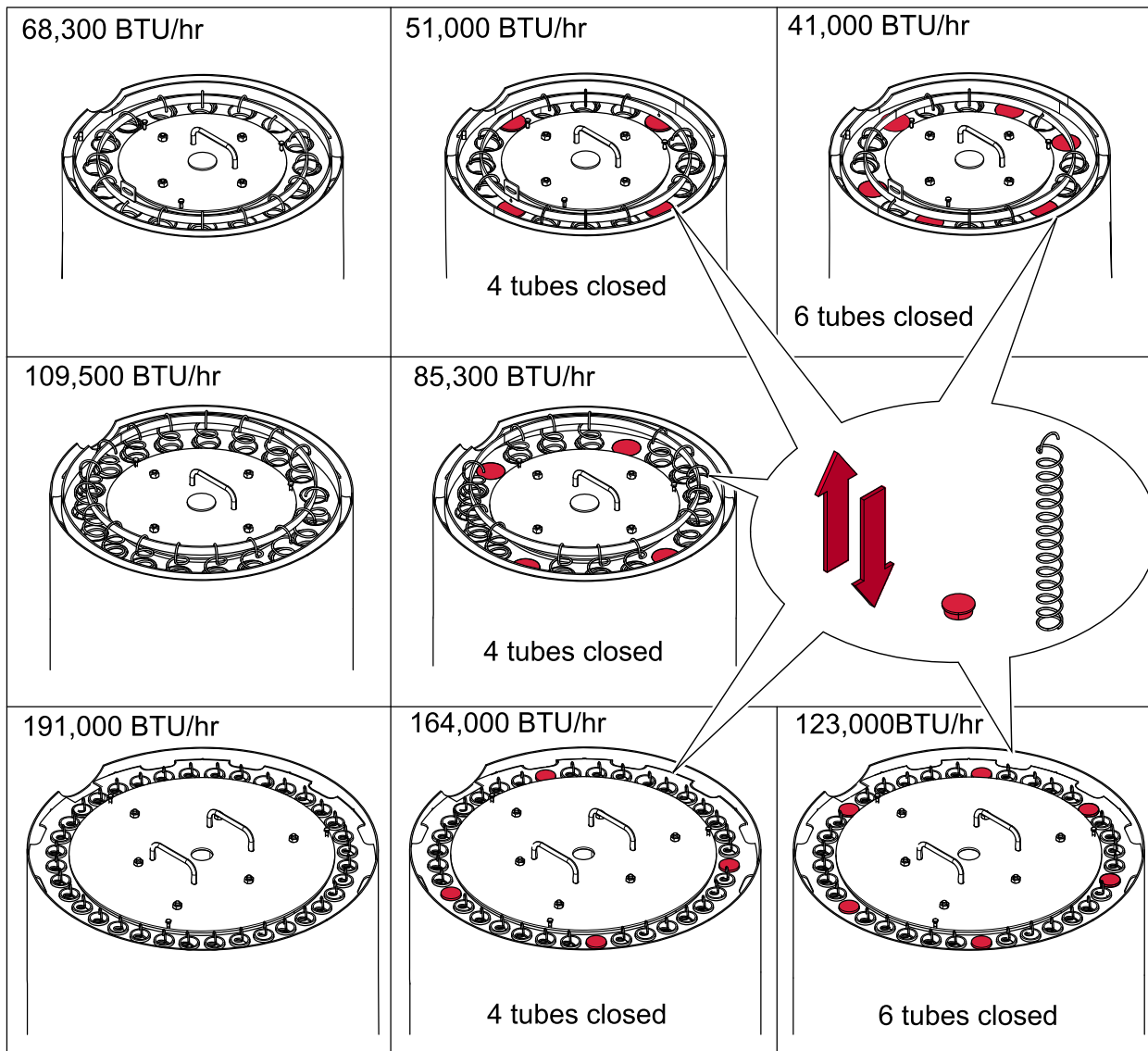

# 12 Appendix

## 12.1 Checklist for checking the heating system

The checklist is intended to help authorised specialists perform and document a comprehensive check on the heating system.

<b>Name and adress of the customer</b>		<b>Heating device</b>	
Name:		Type of boiler:	
Street:		Rated power:	
Place:		Year of build:	
<b>Name and adress of installer</b>		Manufacturer`s serial number:	
Name:		Type of heating controller:	
Street:		Type of accumulator:	
Place:		Solar device:	

### NOTICE

#### Damage to property

Use the checklist to check the heating system before starting up for the first time.

CHECKLIST		Yes	Comment
<b>Textile tank</b>			
Textile tank	Are the tie members installed?		
	Are all legs straightened vertical?		
Delivery unit	Is the slot for the emergency gate valve closed with an adhesive tape?		
Filling coupling	Are the filling couplings correctly installed?		
	Are the plugs at the filling couplings?		
	Are the safety labels placed? (Caution - Switch off the heating system before entering)		
	Are the couplings correctly grounded?		
Ventilation	Is the storage room / building properly ventilated with minimum 27 square inches to the outside?		
Caution label	Is the label "Wood pellets storage room" placed on the door to the storage room?		
Vibration plate	Check the electrical connection of the vibration motor and the capacitive sensor		
<b>If auger delivery system is installed</b>			
Drive unit	Is the direction of rotation correct?		
	Is a demounting possible?		
Spiral hose	Is the pitch to the burner > 45°?		
Sound insulation	Is the rock wool insulation fix at the wall pass through?		
<b>Pellet boiler</b>			

Adjusting power rating	Is the power rating correctly adjusted?		
Burner plate	Is the screw fixing the burner plate, tightened?		
Flame tube	Is the flame tube placed correctly?		
Combustion chamber cover	Are the adjusting screws for the increasing of the flue gas temperature adjusted correctly?		
Flue gas connection	Is a chimney draft regulator, barometric damper implemented?		
Make-up air / ventilation	Does the boiler room have required make-up air?		
Nameplate	Is the nameplate placed on the boiler?		
<b>Electric installation and regulation</b>			
Power supply	Check the electrical connection? (terminal box)		
	Check the ratings of the fuses.		
Settings-Boiler control unit	Are the settings of the boiler control unit according to the installation manual?		
Settings-Heating controller (if used)	Set the parameters, the heating circuit program and domestic hot water program.		
Boiler sensor	Securing location and connection		
<b>Hydronic Connection</b>			
Circuit pumps	Check the switch on temperature (min. 140°F ) for boiler controlled pump (Parameter P 281).		
Low Water Cut Off	Is a low water cut off installed? (terminal box)		
	Test low water device		
Boiler connection	Is the pellet boiler correctly connected		
	Is the hydronic system free of air?		
	Is the system filled up with water? Check the pressure.		
<b>Safety systems</b>			
Fire protection - ball valve	Check the function?		
Safety temp. sensor	Check the installation and explain the function. Securing location and connection		
Negativ draft control	Check the function.		
Safety valve	Is a safety valve installed?		
Emergency stop switch	Is there an emergency stop switch?		
Fire extinguisher	Is there a fire extinguisher?		
<b>Instruction</b>			
Heating-up	Explanation of functions, malfunctions and maintenance to the customer.		
Heating controller	Explanation of the heating controller.		

Operating manual	Explanation of the operating and maintenance regulations to the customer.		
Maintenance contract	Notice to the legal regulations;		

**Date:** \_\_\_\_\_

**Signature authorized installer:**

**Signature customer:**

\_\_\_\_\_

\_\_\_\_\_

The customer confirms that the installer has shown how to operate the boiler, empty the ash box and how to tell if the storage room or FleXILO is requiring more pellets as well as the need to empty the storage unit yearly.

## 12.2 Appendix G of CAN/CSA-B365-M91

Functioning of safety and operating controls

This Annex is not a mandatory part of this Standard, but is written in mandatory language to accommodate its adaption by anyone wishing to do so.

The safety and operating controls shall function within the limits specified by the manufacturer for the type of equipment. The following test shall be performed:

1. Check the operation of the automatic fuel\_feeding interrupt device at each entrance to the floor space within which the fuel-feeding device is installed.
2. Check that when the low water level control on steam and hot water boilers is operated to indicate a low water level, the automatic fuel-feed is interrupted.
3. Check that when the excessive pressure control on steam and hot water boilers is operated as in an excessive pressure situation, the automatic fuel-feed is interrupted.
4. Check that when the excessive water temperature control on steam and hot water boilers is operated to indicate excessive water temperature, the automatic fuel-feed is interrupted and, if appropriate, that one or more zone control valves open.
5. Check that if the temperature exceeds 200°F in a furnace supply plenum on hot air furnaces, the automatic fuel-feed is interrupted.
6. Check that if there is a failure of the fan providing combustion air, the automatic fuel-feed is interrupted.
7. Check that if there is a failure of the combustion air supply control mechanism to remain fully open, the automatic fuel-feed is interrupted.
8. Check that when the hot water circulating pump manual disconnect switch is opened, the automatic fuel-feed is interrupted.
9. Check that if there is a shutdown or failure of the mechanical flue-gas exhauster, the automatic fuel-feed is interrupted.
10. Check that if there is a failure in the flue gas flow, the automatic fuel-feed is interrupted, or the combustion air supply is shut off in manually fuelled appliances.
11. Check for the proper operation of the minimum fire maintenance controls and system or, if applicable, of the automatic ignition system.
12. Check for the proper operation of the controls used for normal automatic fuel-feeding.
13. Check the operation of any other controls supplied on the appliance by the manufacturer, or required by the authority having jurisdiction.

## 12.3 Modifying the burner

The pellet boiler is configured symmetrically. If required, you can remove the burner from the right-hand side (as shipped) and reinstall it on the left.

1. Dismantle the casing, hopper, combustion chamber lid, flame tube, burner and burner plug.
2. Modify the burner on the left.
3. Modify the cleaning system motor and off-set disc.
4. Change the direction of rotation of the cleaning motor.
5. Modify and re-assemble the cleaning system.
6. Route cables through cutouts to the boiler controller and connect up the plug.

### 12.3.1 Dismantling the casing, hopper, combustion chamber lid, flame tube, and burner

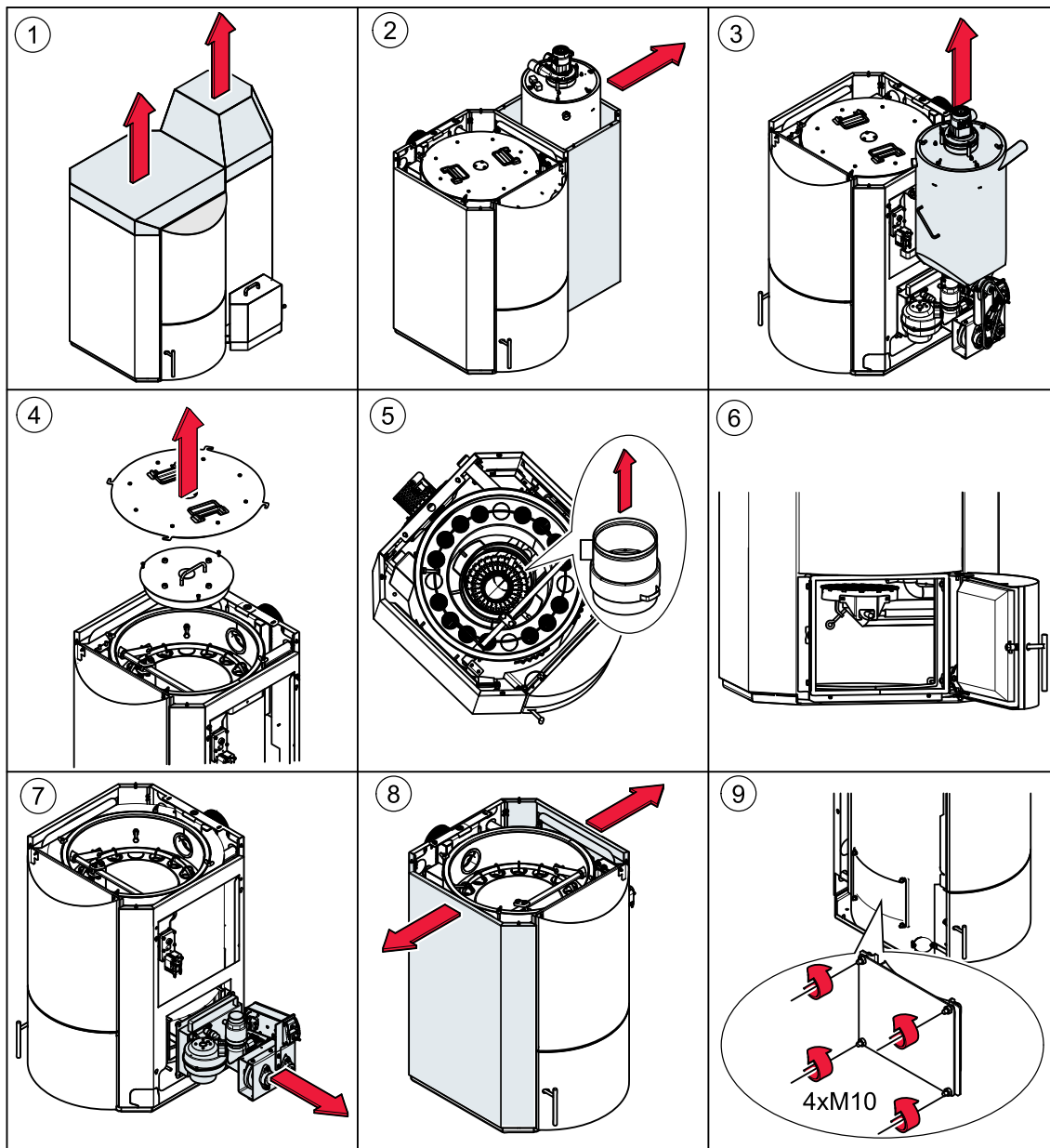

### 12.3.2 Modify the burner on the left

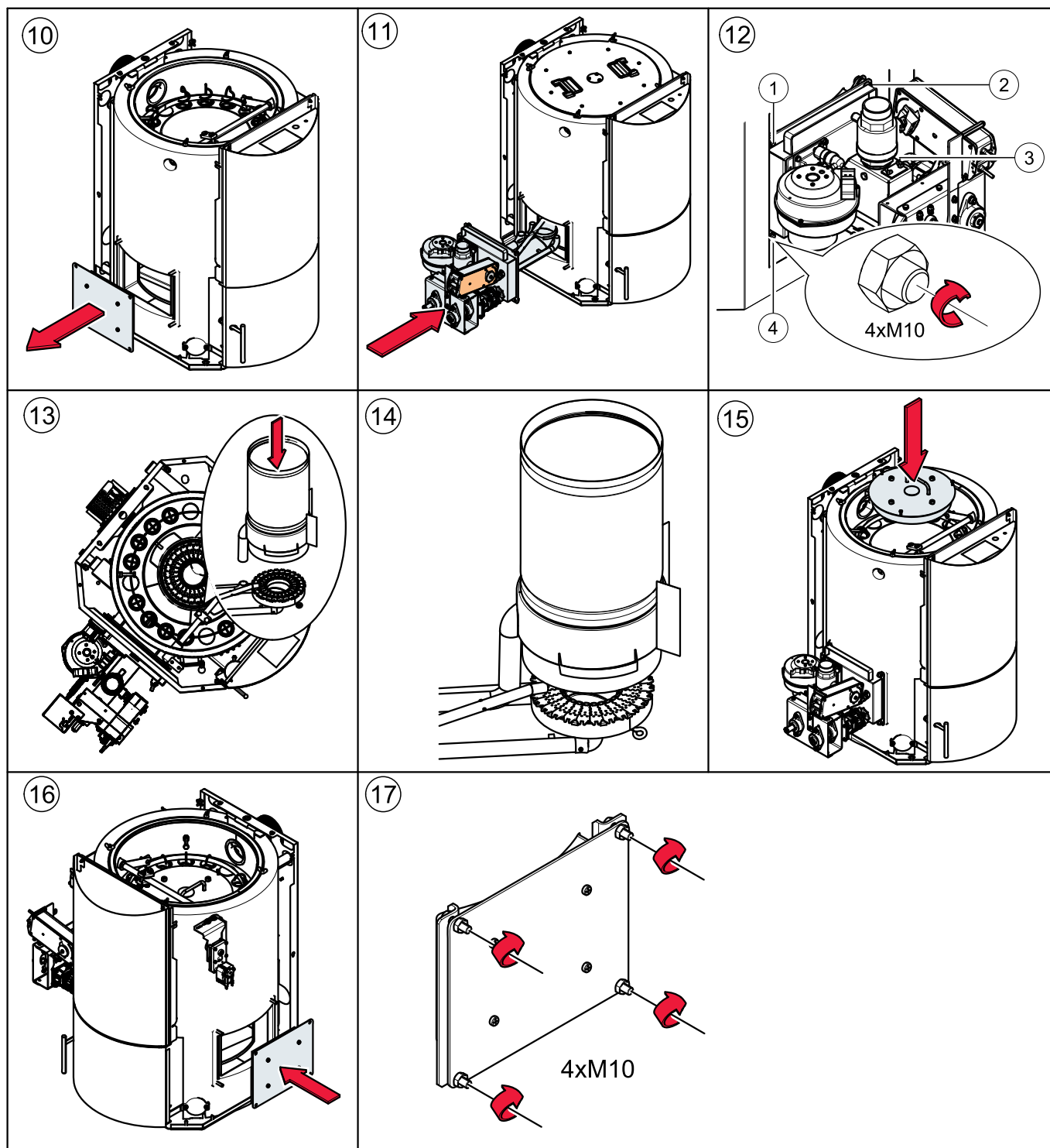

**Note:**

Do not tighten too firm, otherwise the dummy cover could become leaky.



### 12.3.3 Modifying the cleaning system motor and off-set disc

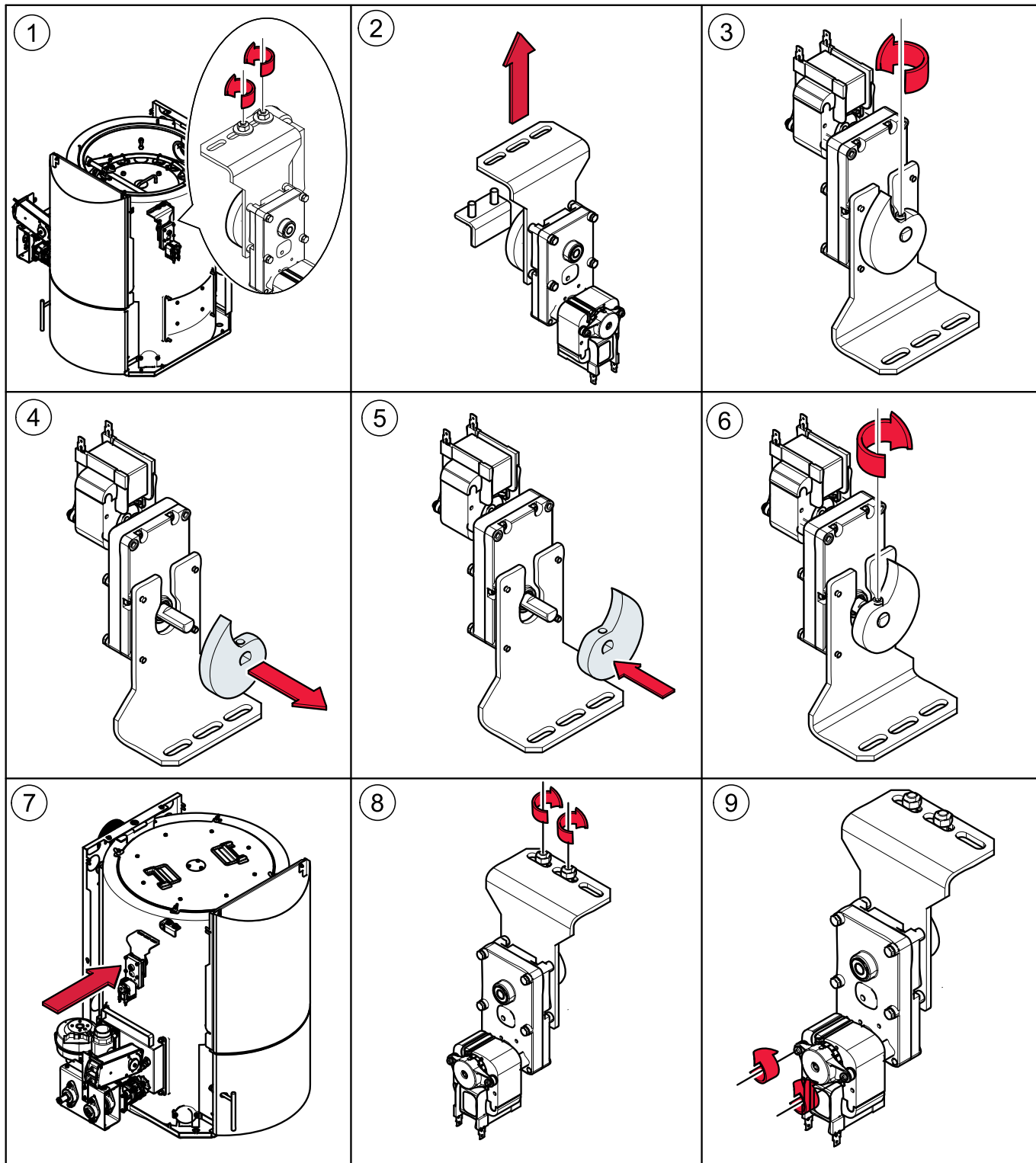

**Note:**

Figure 6: **Glue and tighten** the hex-socket nut to secure the off-set disc.

### 12.3.4 Changing the direction of rotation of the cleaning motor

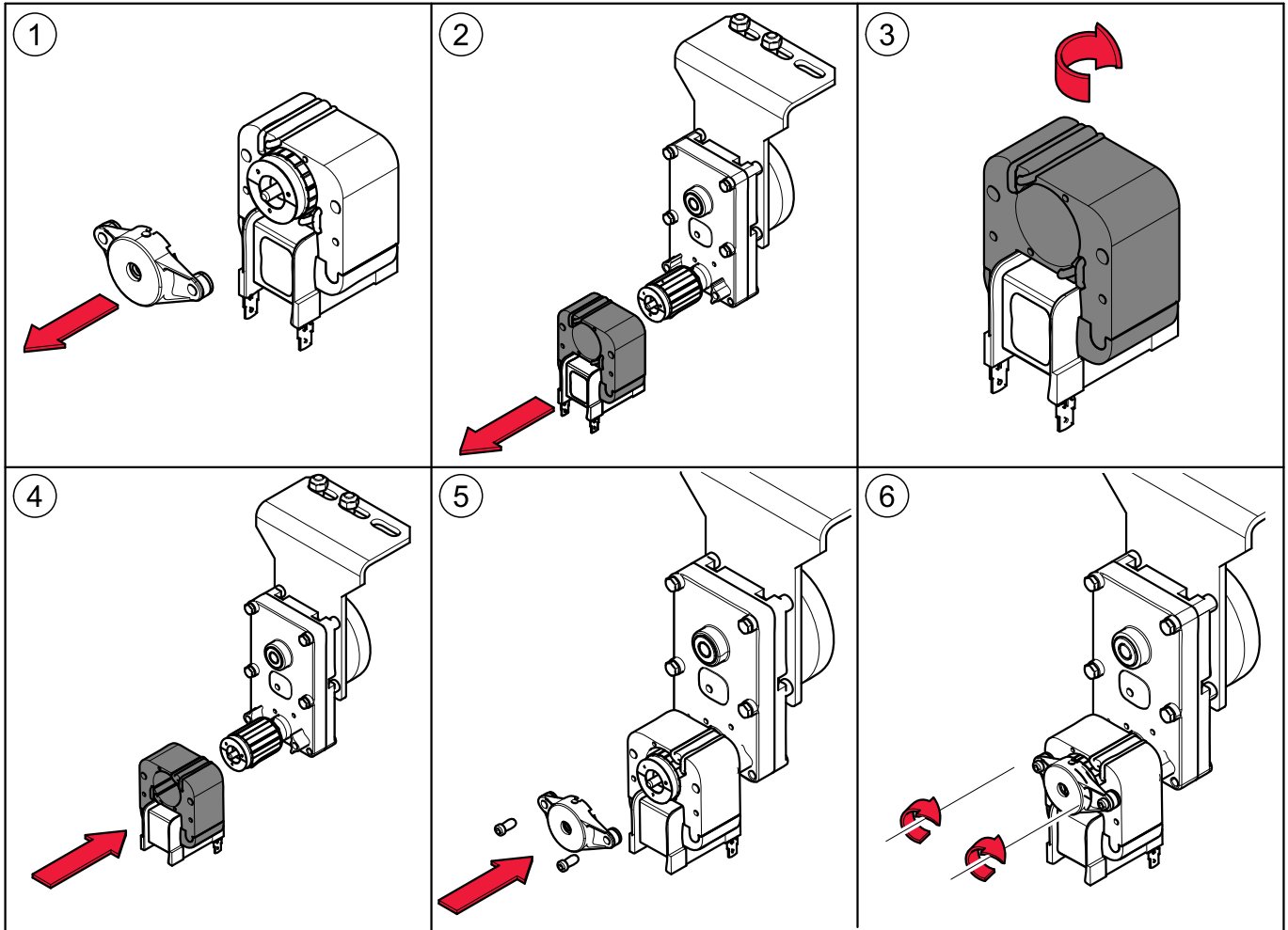

### 12.3.5 Modifying and re-assembling the cleaning system

#### Setting up the cleaning system:

- Switch on the pellet boiler.
- Select "Output test" of the boiler controller for the **boiler cleaning motor**.
- Push the lever mechanism of the cleaning system against the cleaning shaft.
- Press the clip on the cleaning shaft against the off-set disc and switch on the cleaning motor.
- As soon as the off-set disc causes the clip to spring back, switch off the motor and tighten the shaft clamp as tight as possible.
- Use a lock nut to secure the shaft mounting.

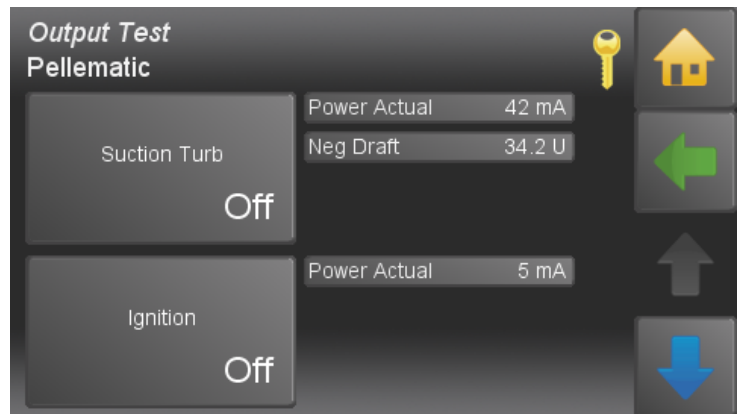

#### Fine adjustment:

- If the cleaning system does not lift high enough: loosen the mounting angle, push forward in the slots and tighten again.
- If the cleaning system stops at the limit bolt: loosen the mounting angle, push back in the slots and tighten again.

#### Note:

The motor mounting must not be able to move and the motor must rotate easily.

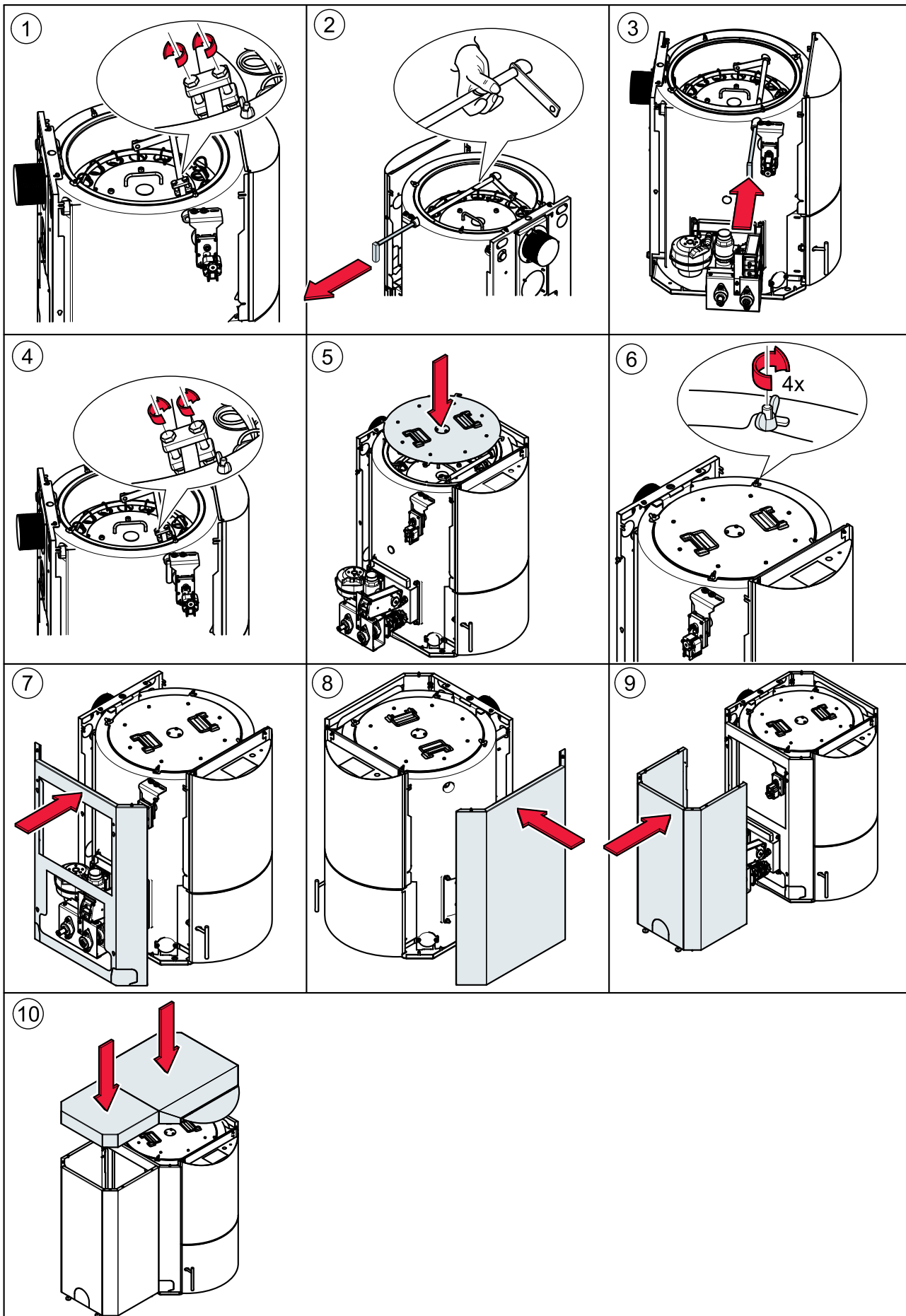

## 12.4 Parts list

### 12.4.1 Pellematic PES 10 - 20 34,000 - 68,300 BTU/hr

Pos.	Article number	Pos.	Article number	Pos.	Article number
1	PE114	26	PE120 (B, G, R)	49	PE143
2	PE119	27	121159	50	PE129
2	PE119B	28	PE121 (B, G, R)	51	121049 / 121126
2	PE119G	29	E1412	52	PE103
2	PE119R	29a	PE564	53	PE142
3	PE200	29b	E1411	54	E1054
4	PE156	29c	E1330	54a	E1186
5	PE289	29d	E1238	55	121169
6	PE215	29e	E1073	56	121168
7	121259	30	on request	57	PE281
8	PE429	31	PE191	58	B103
9	121347	32	on request	58a	PE277S
10	121082 / 121037	33	PE160	59	PE133
11	PE131	34	PE176	60	PE475
12	PE212	35	on request	61	121380
13	PE174	36	121039	62	PEASCH RE - LI
14	121373	37	PE416 / PE413	63	24155 / 24157 / 121198 / 24315
15	on request	38	121410	64	PE 467 / 121327
16	121034	39	121042	65	PE 192
17	121381	40	121379	66	24169
18	O41876	41	121083 / 121029	67	PE260
19	PE185	42	PE188	68	PE419
20	121109 / 121255	43	PE115	69	PE330
21	PE123	44	PE117.1	69a	PE135
22	121123	45	PE117	69b	PE139
23	B0020 / B0020BR	46	PE209	69c	PE136
24	PE116	47	PE258	69d	PE134
25	PE118	48	E1001A		

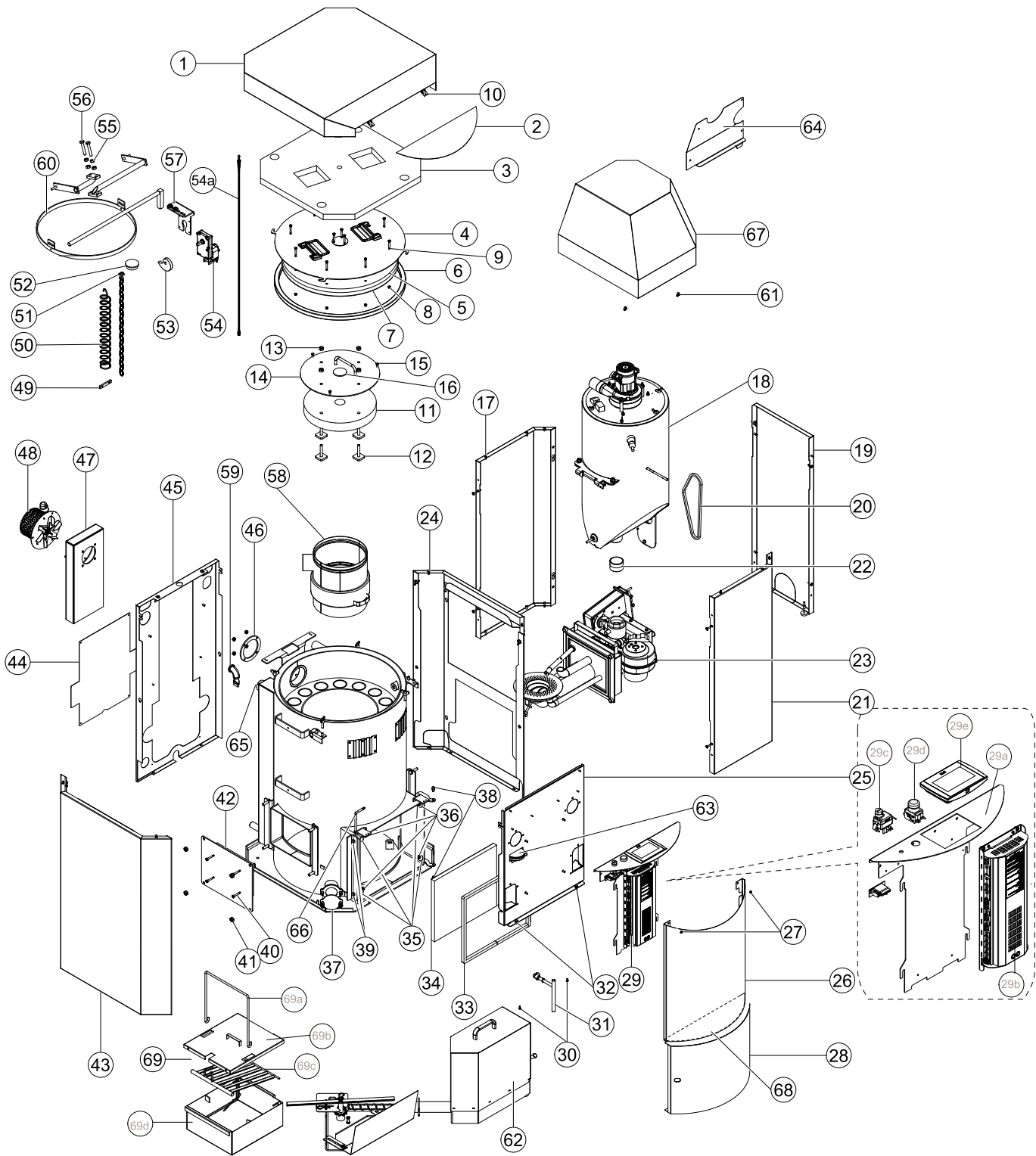

**B0020 / B0020 BRE**

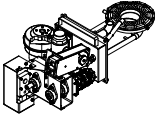
	B0020	Burner without capacitive sensor, WITHOUT Burner plate cleaning system
	B0020BR-E	Burner without capacitive sensor, WITH Burner plate cleaning system

1	121041	19	121196	37	121041
2	121058	20	B172	38	B147
3	B150	21	121197	39	121082
4	121039	22	121023	40	B152
5	121038	23	B130	41	B144
6	121011	24	121041	42	B136
7	121195	25	121037	43	E1413E
8	121051	26	121079	44	B225
9	B179	27	E1030 / E1002.1	44a	B101
10	121082 / 121037	28	121166	45	121034 / 121082
11	B129	29	121039	46	121034 /121037 / 121082
12	121075	30	121038	47	B181
13	121193	31	B113	48	E1204 / E1002.1
14	121194	32	E1059	49	B182
15	121192	33	E1004	50	B183
16	121010	34	B105	51	B184
17	121083 / 121029	35	E1005	52	B196
18	121039 / 121038	36	B202	53	121361

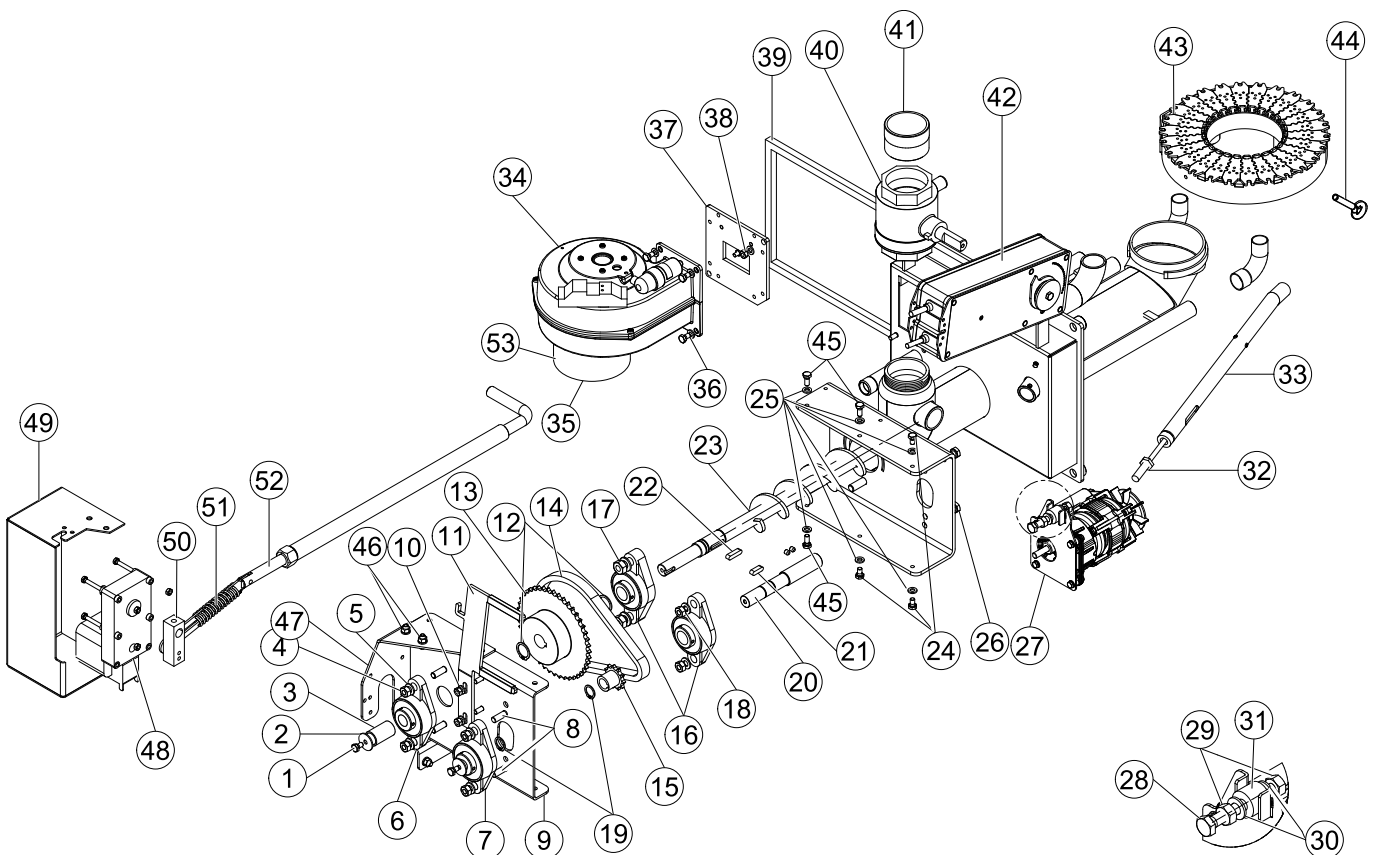

<b>041876 - Hopper</b>			
1	E1138	7	E1368
2	121114	8	O41870
3	121010	9	E1205
4	O41070	10	O41869
5	O41071	11	O41868
6	121122		

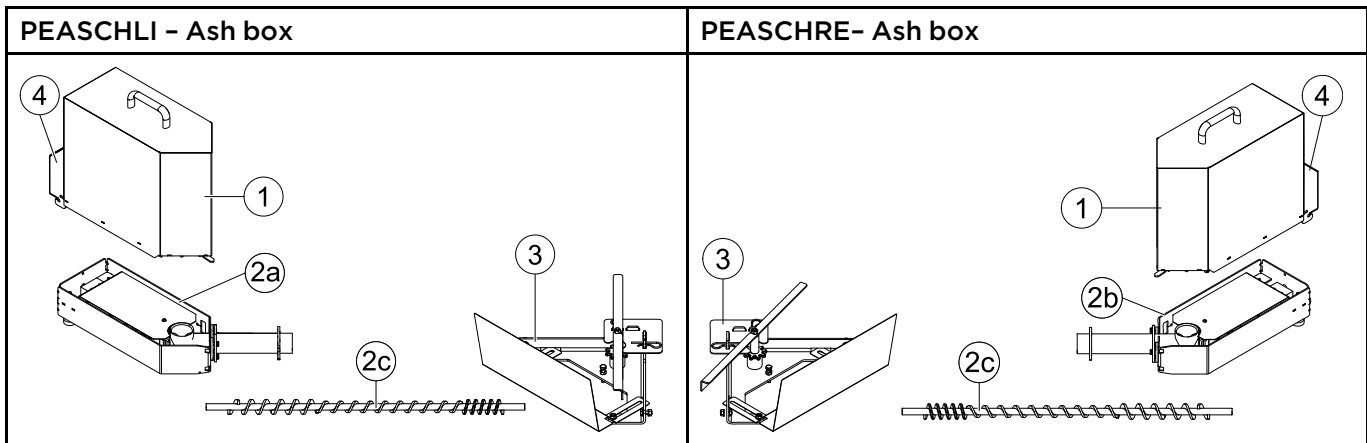
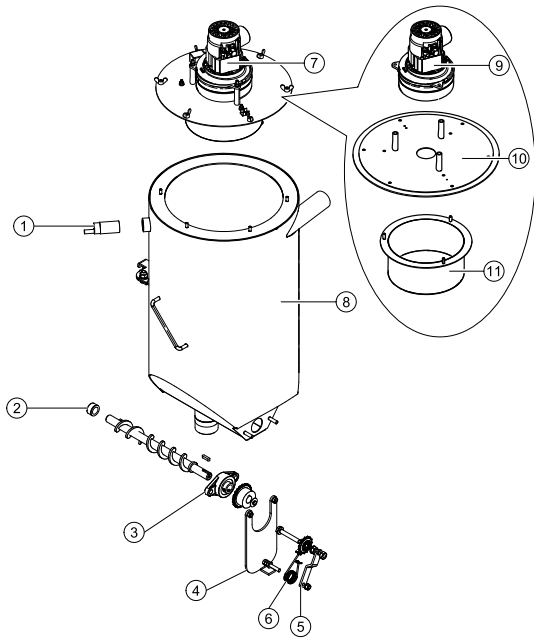

1	PE442	3	PE373		PE436
2a	PE440	4	PE453		121296
2b	PE439		PE347		PE292

**12.4.2 Pellematic PES 25 - 32 / Boiler 85,300 - 109,500 BTU/hr**

Pos.	Article number	Pos.	Article number	Pos.	Article number
1	PE166	26	PE173B	46	PE209
2	PE119	26	PE173G	47	PE406
2	PE119B	26	PE173R	48	E1001A
2	PE119G	27	121159	49	PE143
2	PE119R	28	PE121	50	PE130
3	PE205	28	PE121B	51	121050 / 121126
4	PE157	28	PE121G	52	PE103
5	PE290	28	PE121R	53	PE142
6	PE215	29	E1412	54	E1054
7	121259	29a	PE564	54a	E1186
8	PE430	29b	E1411	55	121169
9	121347	29c	E1330	56	121168
10	PE244	29d	E1238	57	PE281
11	PE131	29e	E1073	58	B104
12	PE213	30	on request	58a	PE277S
13	PE174	31	PE191	59	PE207
14	121373	32	121378	60	PE476
15	PE244.1	33	PE160	61	121380
16	121034	34	PE176	62	PEASCH RE - LI
17	121381	35	on request	63	24155 / 24157 / 121198 / 24315
18	041886	36	121039	64	PE 467 / 121327
19	PE186	37	PE416 / PE413	65	PE192
20	121109	38	121410	66	24169
20	121255	39	121042	67	PE260
21	PE183	40	121379	68	PE419
22	121123	41	121083 / 121029	69	PE331
23	B0030/B0030BR	42	PE188	69a	PE135
24	PE172	43	PE171	69b	PE140
25	PE181	44	PE117.1	69c	PE138
26	PE173	45	PE182	69d	PE137



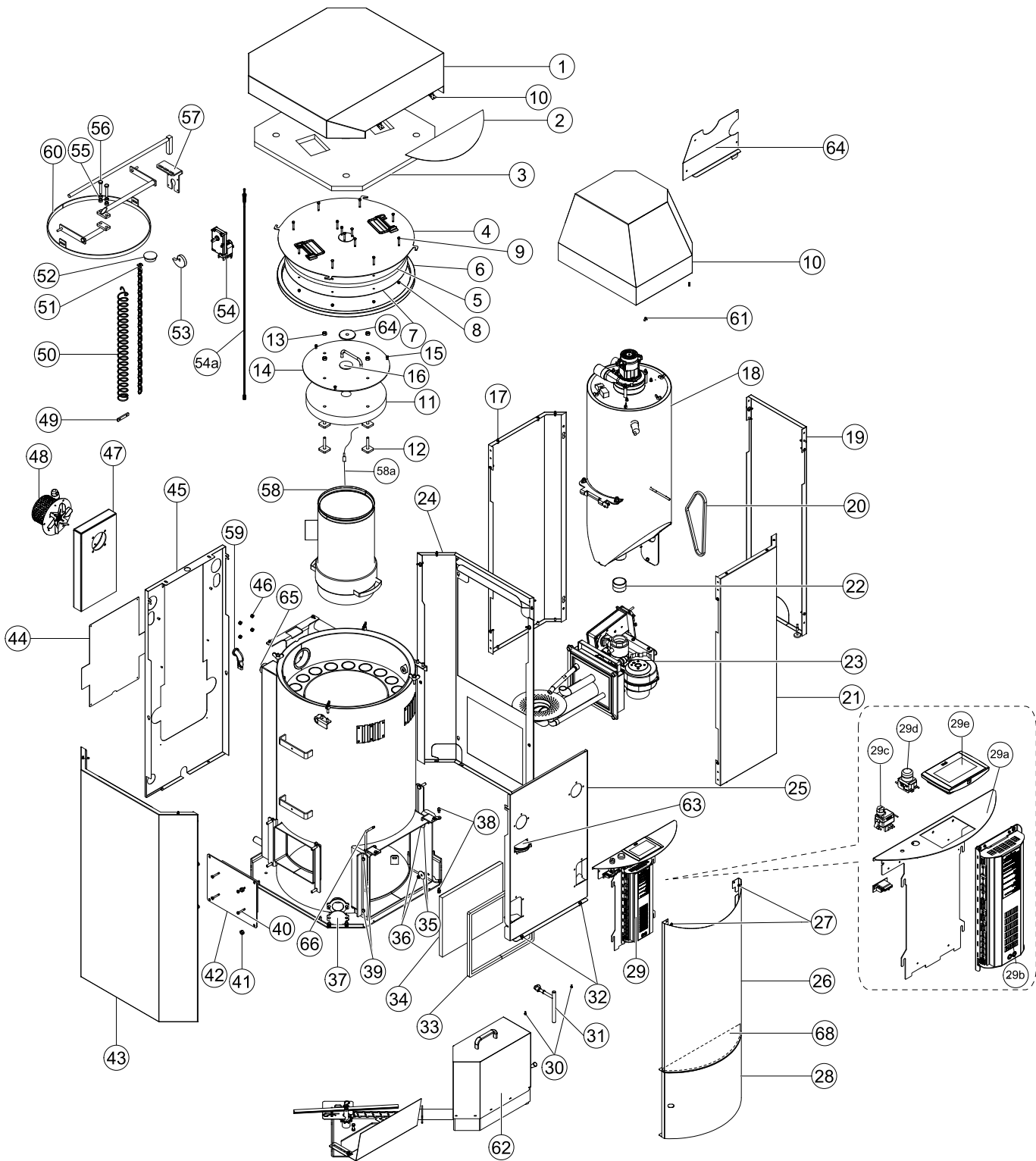

**B0030 / B0030 BRE**

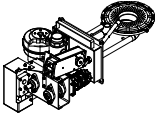
	B0030	Burner without capacitive sensor, WITHOUT burner plate cleaning system
	B0030BRE	Burner without capacitive sensor, WITH burner plate cleaning system

1	121041	19	121196	37	B148
2	121058	20	B172	38	121082
3	B150	21	121197	39	B152
4	121039	22	121023	40	B144
5	121038	23	B131	41	B132
6	121011	24	121041	42	E1413E
7	121195	25	121037	43	B226E
8	121051	26	121079	44	121284
9	B179	27	E1030 / E1002.1	45	121034 / 121082
10	121082 / 121037	28	121166	46	121034 / 121037 / 121082
11	B129	29	121039	47	B181
12	121075	30	121038	48	E1204 / E 1304
13	121193	31	B113	49	B182
14	121194	32	E1004	50	B183
15	121192	33	B105	51	B184
16	121010	34	E1005	52	B197
17	121083 / 121029	35	B202	53	121361
18	121039 / 121038	36	121041		

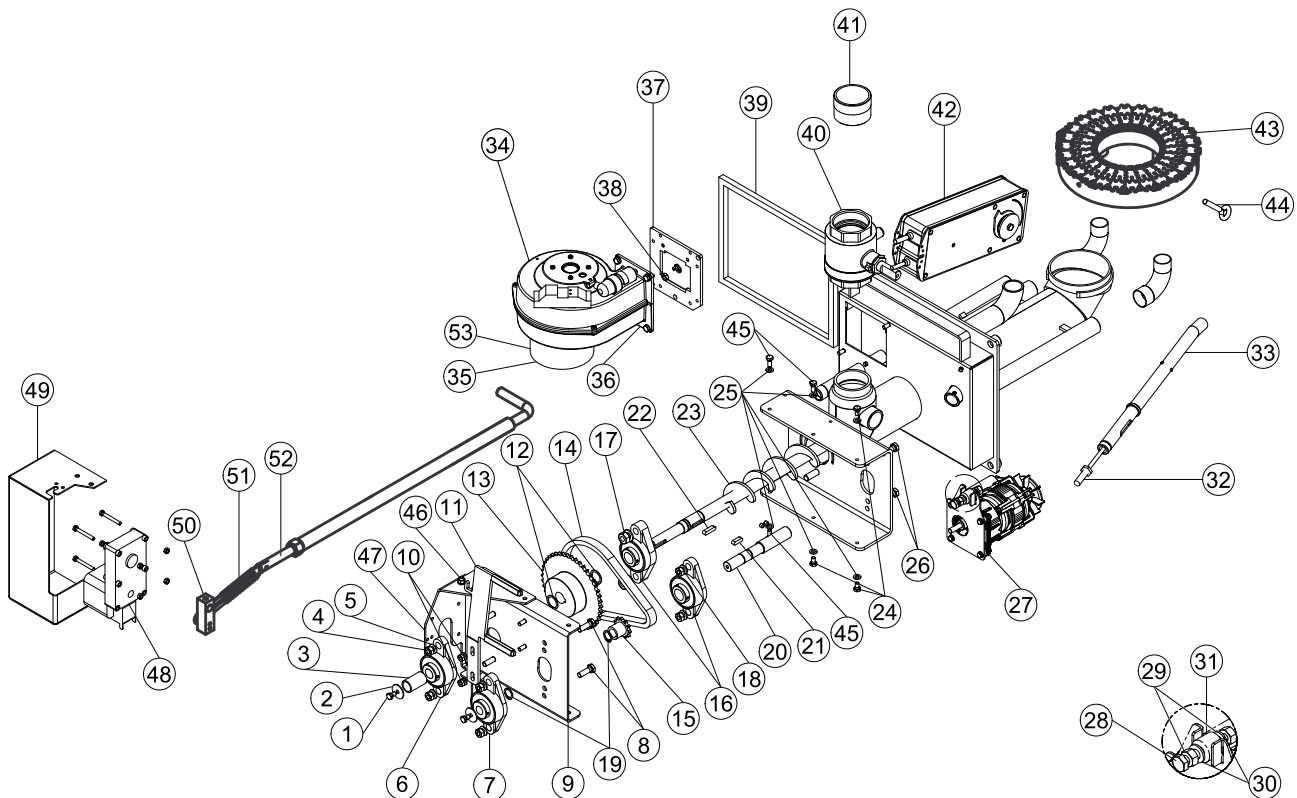

041886 - Hopper			
1	E1138	7	E1368
2	121114	8	O41600
3	121010	9	E1205
4	O41070	10	O41869
5	O41071	11	O41868
6	121122		

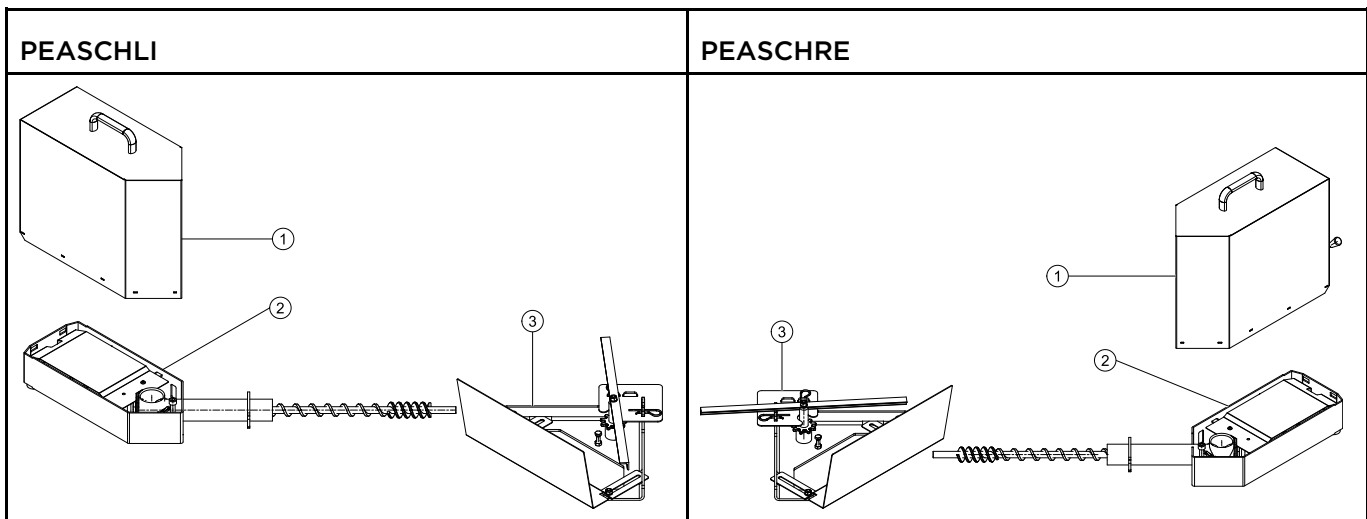
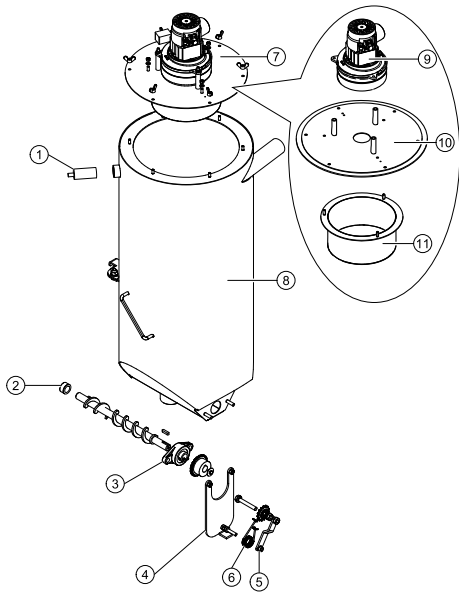

1	PE442	3	PE373	PE436
2a	PE440	4	PE453	121296
2b	PE439		PE347	PE292

## 12.5 Technical data

<b>Boiler - Type</b>		<b>PE(S) 12</b>	<b>PE(S) 15</b>	<b>PE(S) 20</b>	<b>PE(S) 25</b>	<b>PE(S) 32</b>	<b>PES 36</b>	<b>PES 48</b>	<b>PES 56</b>
Boiler-rated power	BTU/hr	41,000	51,000	68,300	85,300	109,500	123,000	164,000	191,000
	kW	12	15	20	25	32	36	48	56
Boiler-partial load	BTU/hr	11.601	17.061	20.473	27.297	34.121	37.534	51.182	58.006
	kW	3,4	5	6	8	10	11	15	17
<b>Measurements</b>									
Width - total (B)	<b>Inch</b>	44 1/2	44 1/2	44 1/2	46 3/4	46 3/4	51	51	51
	<b>mm</b>	1.130	1.130	1.130	1.186	1.186	1.297	1.297	1.297
Width - boiler (C)	<b>Inch</b>	27 1/2	27 1/2	27 1/2	29 3/4	29 3/4	34	34	34
	<b>mm</b>	700	700	700	756	756	862	862	862
Height - boiler (H)	<b>Inch</b>	43	43	43	51	51	61	61	61
	<b>mm</b>	1.100	1.100	1.100	1.300	1.300	1.555	1.555	1.555
Height - vacuum system execution (D)	<b>Inch</b>	55	55	55	63	63	73	73	73
	<b>mm</b>	1.400	1.400	1.400	1.600	1.600	1.855	1.855	1.855
Height - filling unit (F)	<b>Inch</b>	12	12	12	12	12	12	12	12
	<b>mm</b>	300	300	300	300	300	300	300	300
Depth - boiler (T)	<b>Inch</b>	32	32	32	34 1/4	34 1/4	39	39	39
	<b>mm</b>	814	814	814	870	870	990	990	990
Depth - burner casing (V)	<b>Inch</b>	20	20	20	20	20	20	20	20
	<b>mm</b>	508	508	508	508	508	508	508	508
Flow/return - dimensions	<b>Inch</b>	1	1	1	5/4	5/4	2	2	2
Flow/return - height of connection (A)	<b>Inch</b>	35 3/4	35 3/4	35 3/4	43 3/4	43 3/4	52	52	52
	<b>mm</b>	905	905	905	1.110	1.110	1.320	1.320	1.320
Flue size - diameter	<b>Inch</b>	5	5	5	6	6	7	7	7
	<b>mm</b>	130	130	130	150	150	180	180	180
Flue - height of connection (E)	<b>Inch</b>	25 1/2	25 1/2	25 1/2	33 1/4	33 1/4	41	41	41
	<b>mm</b>	645	645	645	844	844	1.040	1.040	1.040
Overall Weight	<b>Lb</b>	631	631	631	756	756	1.120	1.120	1.120
	<b>kg</b>	286	286	286	343	343	508	508	508
Boiler Body Weight	<b>Lb</b>	529	529	529	664	664	930	930	930
	<b>kg</b>	240	240	240	301	301	422	422	422
Efficiency rated power	<b>%</b>	85,4	85,6	85,5	84,9	84,5	85,3	85,4	85,9
Efficiency partial power	<b>%</b>	85,1	84,3	84,2	84,2	84,3	84,1	84,1	84,1
Water capacity	<b>Gal</b>	15,0	15,0	15,0	23,6	23,6	30,6	30,6	30,6
	<b>l</b>	66,0	66,0	66,0	104,0	104,0	135,0	135,0	135,0
<b>Flue gas area</b>									

<b>Boiler - Type</b>		<b>PE(S) 12</b>	<b>PE(S) 15</b>	<b>PE(S) 20</b>	<b>PE(S) 25</b>	<b>PE(S) 32</b>	<b>PES 36</b>	<b>PES 48</b>	<b>PES 56</b>
Fire vault temperature	°F	1652 - 2012							
	°C	900 - 1100							
Fire vault pressure	<b>Inch WC</b>	-0.14							
	<b>mbar</b>	-35							
Flue gas temperature rated power (Flue gas temperature can be adjusted)	°F	320							
	°C	160							
Flue gas temperature partial load (Flue gas temperature can be adjusted)	°F	212							
	°C	100							
Flue gas inertia current rated power	<b>Lb/hr</b>	49,60	62,17	82,89	99,43	115,96	149,25	198,85	231,92
	<b>kg/h</b>	22,50	28,20	37,60	45,10	52,60	67,70	90,20	105,20
Flue gas inertia current partial load	<b>Lb/hr</b>	14,11	20,72	24,91	29,76	35,71	45,64	62,17	70,33
	<b>kg/h</b>	6,40	9,40	11,30	13,50	16,20	20,70	28,20	31,90
Flue gas volume rated power	<b>Cft/hr</b>	918	1.232	1.642	1.971	2.627	2.956	3.941	4.598
	<b>m³/h</b>	26	35	47	56	74	84	112	130
Flue gas volume partial load at flue gas temperature	<b>Cft/hr</b>	240	353	424	509	607	777	1.059	1.204
	<b>m³/h</b>	7	10	12	14	17	22	30	34
Chimney diameter	according to chimney calculation								
Chimney construction	steel or ceramic lined, withstand humidity								
Electrical connection	<b>USA and Canada</b>	208 to 240 VAC, single phase, 60 Hz, 15 amp dedicated circuit.							
<b>Water area</b>									
Water resistance at 10K	<b>In WC</b>	38,22	60,22	88,32	114,02	150,95	15,62	20,84	24,29
	<b>mbar</b>	95,20	150,00	220,00	284,00	376,00	38,90	51,90	60,50
Water resistance at 20K	<b>In WC</b>	9,72	15,26	22,08	28,91	38,14	4,18	5,58	6,50
	<b>mbar</b>	24,20	38,00	55,00	72,00	95,00	10,40	13,90	16,20
Boiler temperature	°F	149 - 194							
	°C	65 - 90							
Boiler input temperature minimum	°F	131							
	°C	55							
Operating pressure maximum	<b>psi</b>	50							
	<b>bar</b>	3							
Test pressure	<b>psi</b>	67							
	<b>bar</b>	4,60							

<b>Boiler - Type</b>		<b>PE(S) 12</b>	<b>PE(S) 15</b>	<b>PE(S) 20</b>	<b>PE(S) 25</b>	<b>PE(S) 32</b>	<b>PES 36</b>	<b>PES 48</b>	<b>PES 56</b>
Flue gas volume rated power at flue gas temperature	<b>Cft/hr</b>	1.010,0	1.327,8	1.772,8	2.231,9	2.874,6	3.217,2	4.262,5	4.944,1
	<b>m³/h</b>	28,6	37,6	50,2	63,2	81,4	91,1	120,7	140,0
Flue gas volume partial load at flue gas temperature	<b>Cft/hr</b>	243,7	384,9	459,1	614,5	769,9	847,6	1.165,4	1.313,7
	<b>m³/h</b>	6,9	10,9	13,0	17,4	21,8	24,0	33,0	37,2
<b>Fuel</b>	<b>USA</b>	According to PFI Premium Standards or EnPlus -A1 pellets							
	<b>Europe</b>	According to EN14961-2 Standards (A1 Class)							
Colorific value	<b>BTU/lbs</b>	> 7.200							
	<b>MJ/kg</b>	>16,5							
Bulk density	<b>Lb/cft</b>	> 40,00							
	<b>kg/m³</b>	>600							
Water content	<b>Mass%</b>	<10							
Ash content	<b>Mass%</b>	<1							
Lenght	<b>Inch</b>	11/4 - 11/2							
	<b>mm</b>	3,15 - 40							
Diameter	<b>Inch</b>	1/4 - 5/16							
	<b>mm</b>	6,00 - 8,00							
Fine material	<b>Mass%</b>	<0.5							
	<b>Mass%</b>	<1%							
Ash melting point	<b>°F</b>	> 2.200							
	<b>°C</b>	> 1.200							
Contents	<b>USA</b>	untreated wood							
	<b>Europe</b>	stemwood or chemically untreated wood							
<b>Components</b>									
Internal ash pan volume	<b>Gal</b>	5,68			6,81		-		
	<b>lb</b>	25			30		-		
External ash box volume	<b>Gal</b>	4,54					5,675		
	<b>lb</b>	20					25		
Main Drive	<b>W</b>	40							
Drive Motor	<b>W</b>	250/370							
Suction Turbine	<b>W</b>	1200							
Combustion Air Blower	<b>W</b>	83							
Suction Fan Blower	<b>W</b>	32							
Electrical Ignition	<b>W</b>	250							
Cleaning Motor	<b>W</b>	40							

Boiler - Type		PE(S) 12	PE(S) 15	PE(S) 20	PE(S) 25	PE(S) 32	PES 36	PES 48	PES 56
Motor External Ash Box	<b>W</b>	40							
Fire protection motor	<b>W</b>	5							

The data are values of the test measurement and can vary from locally measured values









WB Federal Institute of Agricultural Engineering Wieselburg  
Address: A-3250 Wieselburg, Rottenhauserstraße 1; Tel.: +43-7416-52175-0

**Note:**





Test reports are available

## 12.6 Pellet boiler cautionary markings

### Labeling 60x30







 <p>BEFORE OPENING TURN OFF THE MAIN SWITCH</p>	<p>TO START THE SYSTEM PRESS THE GREEN ON/OFF BUTTON</p>	<p>THE CONTAINER CAN BE TAKEN DOWN ONLY BY LOOSENING THE YELLOW LOCKING SCREW</p> 
<p> <b>CAUTION</b></p> <p>DO NOT ALTER THIS EQUIPMENT IN ANY WAY LOSS OF WARRANTY</p>	<p> <b>CAUTION</b></p> <p>POWER SOURCE NOT CONTROLLED BY SUCTION TURBINES MAIN DISCONNECT</p>	<p> <b>CAUTION</b></p> <p>POWER ORIGINATED FROM A SOURCE OF POWER OTHER THAN THIS MOTOR</p>
<p> <b>CAUTION</b></p> <p>DO NOT REMOVE THE SNAP RING! LOSS OF WARRANTY</p>	<p> <b>CAUTION</b></p> <p>FOR USE WITH WOOD PELLET FUEL ONLY LOSS OF WARRANTY</p>	<p> <b>CAUTION</b></p> <p>VACUUM SUCTION SYSTEMS: REMOVE THE PROTECTIVE CAP FROM THE BALL VALVE</p>

### Labeling 99x34

<p> <b>DANGER</b></p> <p>TO AVOID INJURY FROM MOVING PARTS, SHUT OFF THE MAIN CONTROLLER BEFORE REMOVING THIS COVER</p>	<p><b>CONTACT LOCAL BUILDING OR FIRE OFFICIALS ABOUT RESTRICTIONS AND INSTALLATION INSPECTION IN YOUR AREA</b></p>
<p> <b>DANGER</b></p> <p><b>KEEP VIEWING AND ASH REMOVAL DOORS TIGHTLY CLOSED DURING OPERATION!</b></p>	<p> <b>CAUTION</b></p> <p>DO NOT CONNECT THIS UNIT TO A CHIMNEY FUEL SERVING ANOTHER APPLIANCE. <b>SEE LOCAL RESTRICTIONS!</b></p>
<p> <b>CAUTION</b></p> <p>INSTALL AND USE ONLY IN ACCORDANCE WITH INSTALLATION- AND OPERATING INSTRUCTIONS! REFER TO OWNERS MANUAL</p>	<p><b>FORWARD</b></p> <p><b>WATER QUALITY ACC. TO VDI 2035 STANDARD</b> (THE MEDIUM HAS TO BE FREE FROM AIR AND MUD)</p>
<p> <b>DANGER</b></p> <p><b>MOVING PARTS CAUSE INJURY! DO NOT OPERATE WITH REMOVED COVERING!</b></p>	<p><b>RETURN</b></p> <p><b>WATER QUALITY ACC. TO VDI 2035 STANDARD</b> (THE MEDIUM HAS TO BE FREE FROM AIR AND MUD)</p>



Labeling 105x74

<p><b>IN THE CASE OF A “RUN-AWAY” FIRE:</b></p> <ul style="list-style-type: none"> <li>• NEVER PUT YOUR SELF AT RISK OF FATAL INJURY. YOUR SAFETY MUST ALWAYS TAKE HIGHEST PRIORITY!</li> <li>• SWITCH OFF THE HEATING SYSTEM</li> <li>• EXIT THE BUILDING AND CALL YOUR SERVICE CONTRACTOR AND LOCAL FIRE DEPARTMENT</li> </ul>	<div style="background-color: yellow; text-align: center; padding: 5px;">  <b>CAUTION</b> </div> <p style="text-align: center;"><b>HOT SURFACES</b></p> <ul style="list-style-type: none"> <li>• DO NOT TOUCH DURING OPERATION!</li> <li>• KEEP CHILDREN AWAY</li> <li>• KEEP CLOTHING AND COMBUSTIBLE MATERIALS AWAY FROM MARKED CLEARANCES.</li> <li>• MAXIMUM DRAFT MARKED ON NAMEPLATE</li> </ul>
<div style="background-color: yellow; text-align: center; padding: 5px;">  <b>CAUTION</b> </div> <p style="text-align: center;">IN THE CASE OF A CONNECTING BOILER CONTACT A SERVICE TECHNICIAN FOR COMPLIANCE INFORMATION BEFORE CONNECTING! MAY BE CONNECTED TO AN EXISTING BOILER SYSTEM</p> <p style="text-align: center;">THE FOLLOWING UNIT IS APPROVED FOR CONNECTING WITH THE AUTOPELLET SYSTEM:</p> <p>MODEL NUMBER CONNECTED UNIT: _____ ITEM NUMBER CONNECTED UNIT: _____</p>	<div style="background-color: orange; text-align: center; padding: 5px;">  <b>WARNING</b> </div> <p style="text-align: center;">RISK OF FIRE!</p> <ul style="list-style-type: none"> <li>• DO NOT OPERATE WHILE FLUE DRAFT EXCEEDS -.11 INCHES WC!</li> <li>• DO NOT OPERATE WITH DOORS OPEN!</li> <li>• DO NOT STORE FUEL OR OTHER COMBUSTIBLE MATERIAL WITHIN MARKED INSTALLATION CLEARANCES!</li> <li>• INSPECT AND CLEAN FLUE AND CHIMNEY REGULARLY!</li> <li>• DO NOT USE CHEMICALS TO START UNIT FIRING</li> <li>• DO NOT BURN GARBAGE, GASOLINE, FUEL OILS OR OTHER FLAMMABLE LIQUIDS OR MATERIALS</li> </ul>
<div style="background-color: red; text-align: center; padding: 5px;">  <b>DANGER</b> </div> <p style="text-align: center;">HOT SURFACES AND MOVING PARTS MAY CAUSE INJURY!</p> <p style="text-align: center;">RISK OF FIRE OR EXPLOSION – DO NOT BURN GARBAGE, GASOLINE, FUEL OILS OR OTHER FLAMMABLE LIQUIDS OR MATERIALS</p>	<div style="background-color: yellow; text-align: center; padding: 5px;">  <b>CAUTION</b> </div> <p style="text-align: center;">UNSAFE TO ADJUST FLUE DRAFT HIGHER THAN .11 INCHES WATER COLUMN</p> <ul style="list-style-type: none"> <li>• MIN DRAFT @ LOW FIRE -.02 INCHES WC</li> <li>• MIN DRAFT @ HIGH FIRE -.04 INCHES WC</li> <li>• MAX DRAFT -.11 INCHES WC</li> </ul>
<div style="background-color: yellow; text-align: center; padding: 5px;">  <b>CAUTION</b> </div> <p>THE HEAT EXCHANGER, FLUE PIPE AND CHIMNEY MUST BE CLEANED REGULARLY TO REMOVE ACCUMULATED CREOSOTE AND ASH, ENSURE THAT THE HEAT EXCHANGER, FLUE PIPE, AND CHIMNEY ARE CLEANED AT THE END OF THE HEATING SEASON TO MINIMIZE CORROSION DURING THE SUMMER MONTHS, THE APPLIANCE FLUE PIPE AND CHIMNEY MUST BE IN GOOD CONDITION. THESE INSTRUCTIONS ALSO APPLY TO A DRAFT INDUCER IF USED.</p>	<p style="text-align: center;">LOSS OF ELECTRICAL POWER</p> <p style="text-align: center;"><b>NO DANGER</b> PELLET BOILER COOLS DOWN AUTOMATICALLY</p> <hr/> <p style="text-align: center;"><b>INSPECT AND CLEAN EXHAUST VENTING SYSTEM FREQUENTLY</b></p>



**MESys**  
 Maine Energy Systems, LLC  
 8 Airport Road, Bethel, Maine 04217  
 Voice: 207.824.6749 Fax: 207.824.4816

Report No. 0444PB004S

<b>Type:</b> Pellematic20		<b>S/N:</b> XUT xx	<b>CATALOG No.:</b> PES20
<b>Date of manuf.:</b> 02/2018		<b>Rated heat power:</b> 68,300BTU/hr	
<b>Tested to:</b> UL 2523-2013. CSA B366.1-2011 EN303-5			
<b>Manufactured By:</b> MESys LLC, Bethel, Maine		<b>FUEL:</b> WOOD PELLETS	
U.S. ENVIRONMENTAL PROTECTION AGENCY certified to comply with the 2020 particulate emissions standard using wood pellets.			
This appliance needs periodic inspection and repair for proper operation. Consult owner's manual for further information. It is against federal regulations to operate this appliance in a manner inconsistent with operating instructions in the owners manual.			
<b>Particulate Emissions,</b> 0.028 lb./million btu - 0.227 grams/hr. <b>CO emissions,</b> 0.019 grams/min. <b>Annual Efficiency,</b> (HHV) 74.3%			
<b>Water Capacity:</b> 15.0 Gallons		<b>Operating Temp:</b> 194 °F	
<b>Max Operating Pressure:</b> 3 BAR / 43.5 PSI / 1204 inches WC			
<b>Chimney</b>	Approved factory built stainless steel or tile-lined masonry		
<b>MAX DRAFT:</b> 0.11 inches WC <b>MIN DRAFT:</b> 0.04 inches WC			
<b>Diameter:</b> 6 INCH		<b>Electrical Rating:</b> 220 V, 60 Hz, 14 A, 1760 W	
<b>FLOORING:</b> COMBUSTIBLE FLOORS CAN BE USED WITH A NON-COMBUSTIBLE SHIELD. MINIMUM CLEARANCES ARE 18IN/457MM IN THE FRONT AND 8IN / 203MM ON EACH SIDE.			
<b>PARTS</b>	<b>Fan Flue Gas:</b> E1001A	<b>Controller Display:</b> E1330	
<b>Motor Ash Box:</b> E1302		<b>Motor Flame Return Protection:</b> E1413A	
<b>Motor Cleaning Device:</b> E1054		<b>Motor Hopper:</b> NA	
<b>Motor Burner Plate Cleaning:</b> NA		<b>Suction Turbine:</b> E1205	
<b>Motor Burner Screw:</b> E1030		<b>Low Water Cut Off:</b> Safgard 550SV	
<b>Controller Board:</b> E1412		<b>Pressure-Relief Valve:</b> Watts Co335M1	
<b>Motor Auger Screw:</b> FKAEM 150 / FKAE-S		<b>Fan Burner:</b> E1005S	



**MESys**  
**Maine Energy Systems, LLC**  
**8 Airport Road, Bethel, Maine 04217**  
**Voice: 207.824.6749 Fax: 207.824.4816**

Report No. 0444PB004S

<b>Type:</b> Pellematic32		<b>S/N:</b> XUT xx	<b>CATALOG No.:</b> PES32
<b>Date of manuf.:</b> 02/2018		<b>Rated heat power:</b> 109,000 BTU/hr	
<b>Tested to:</b> UL 2523-2013. CSA B366.1-2011 EN303-5			
<b>Manufactured By:</b> MESys LLC, Bethel, Maine		<b>FUEL:</b> WOOD PELLETS	
U.S. ENVIRONMENTAL PROTECTION AGENCY certified to comply with the 2020 particulate emissions standard using wood pellets.			
This appliance needs periodic inspection and repair for proper operation. Consult owner's manual for further information. It is against federal regulations to operate this appliance in a manner inconsistent with operating instructions in the owners manual.			
<b>Particulate Emissions,</b> 0.021 lb./million btu - 0.319 grams/hr. <b>CO emissions,</b> 0.025 grams/min. <b>Annual Efficiency, (HHV)</b> 76.5%			
<b>Water Capacity:</b> 23.6 Gallons		<b>Operating Temp:</b> 194 °F	
<b>Max Operating Pressure:</b> 3 BAR / 43.5 PSI / 1204 inches WC			
<b>Chimney</b>	Approved factory built stainless steel or tile-lined masonry		
<b>MAX DRAFT: 0.11 inches WC MIN DRAFT: 0.04 inches WC</b>			
<b>Diameter:</b> 6 INCH		<b>Electrical Rating:</b> 220 V, 60 Hz, 14 A, 1760 W	
<b>FLOORING:</b> COMBUSTIBLE FLOORS CAN BE USED WITH A NON-COMBUSTIBLE SHIELD. MINIMUM CLEARANCES ARE 18IN/457MM IN THE FRONT AND 8IN / 203MM ON EACH SIDE.			
<b>PARTS</b>	<b>Fan Flue Gas:</b> E1001A	<b>Controller Display:</b> E1330	
<b>Motor Ash Box:</b> E1302		<b>Motor Flame Return Protection:</b> E1413A	
<b>Motor Cleaning Device:</b> E1054		<b>Motor Hopper:</b> NA	
<b>Motor Burner Plate Cleaning:</b> NA		<b>Suction Turbine:</b> E1205	
<b>Motor Burner Screw:</b> E1030		<b>Low Water Cut Off:</b> Safgard 550SV	
<b>Controller Board:</b> E1412		<b>Pressure-Relief Valve:</b> Watts Co335M1	
<b>Motor Auger Screw:</b> FKAEM 150 / FKAE-S		<b>Fan Burner:</b> E1005S	

## Author & Manufacturer

MAINE ENERGY SYSTEMS LLC  
 8 Airport Road – P.O. Box 547 Bethel  
 Maine 04217

E-Mail: [info@maineenergysystems.com](mailto:info@maineenergysystems.com)  
[www.maineenergysystems.com](http://www.maineenergysystems.com)

© MAINE ENERGY SYSTEMS LLC  
 Subject to modifications